



City of Dallas

Hampton Clarendon Authorized Hearing

**Audiencia Autorizada del Hampton
Clarendon**

Z189-349

**Virtual Community Meeting (Initial Draft)
Reunión Comunitaria Virtual (Borrador Inicial)**

**December 12, 2024
12 de diciembre de 2024**

Jalyn Porchay AICP Candidate, Sr.
Planner
Planning & Development Department
City of Dallas

Agenda



1. Welcome/Introduction/**Bienvenida/Introducción**
2. Recap of Previous Meeting/**Resumen de la reunión anterior**
3. Community Input/**Opinión de la comunidad**
4. Zoning Proposal – P&D / **Propuesta de zonificación – P&D**
5. Q & A / **Preguntas y Respuestas**
6. Next Steps / **Próximos pasos**
7. Adjourn / **Clausura de la reunión**

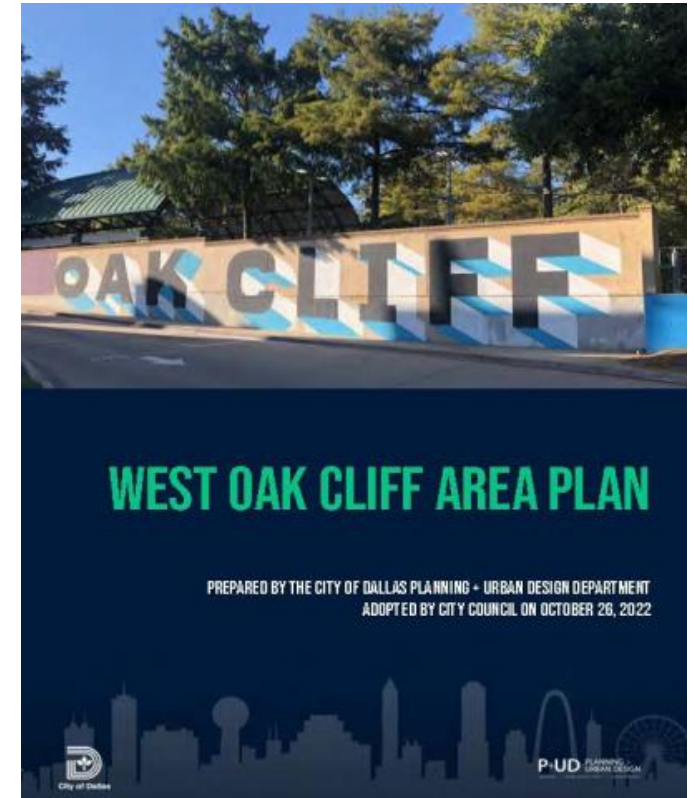



 **Planning & Development**
City of Dallas

HAMPTON - CLARENDON CORRIDOR AUTHORIZED HEARING MEETING WEBINAR

Join the City of Dallas Planning & Development Department for a virtual meeting to discuss the rezoning of properties within the Hampton-Clarendon Corridor. The objective of this meeting is to obtain feedback from the property owners on Staff's proposed zoning recommendations for the Authorized Hearing area. If you did not have an opportunity to attend the last meeting, we invite you to attend one of the two (2) virtual meetings on Thursday, December 12th, 2024 and Friday December 13th, 2024 (Spanish Only).

Join us to learn more, ask questions, and share your feedback.

Register to attend on the website at bit.ly/hamptonclarendonzoning

Two (2) Meeting Dates:

- 1 THURS, DECEMBER 12, 2024**
12:00 PM - 1:30 PM
- 2 FRI, DECEMBER 13, 2024 (SPANISH ONLY)**
12:00 PM - 1:00 PM

 **Email**
JALYN.PORCHAY@DALLAS.GOV

 **Contact us**
214-671-5075

 **Visit our website for the registration**
[BIT.LY/HAMPTONCLARENDONZONING](https://bit.ly/hamptonclarendonzoning)

REGISTER ONLINE





PUBLIC MEETING / REUNIÓN PÚBLICA

Hampton/Clarendon Authorized Hearing Audiencia Autorizada de Hampton/Clarendon (Z189-349)

The City of Dallas Planning & Development Department cordially invites you to a community meeting to discuss the proposed zoning recommendations from the West Oak Cliff Area Plan (WOCAP) for the Hampton-Clarendon Corridor [Z189-349].

El Departamento de Planificación y Desarrollo de la Ciudad de Dallas le invita cordialmente a una reunión comunitaria para discutir las recomendaciones de zonificación propuestas del Plan del Área de West Oak Cliff (WOCAP) para el Corredor Hampton-Clarendon [Z189-349].



Planning & Development



Planning & Development

Dallas City Hall, Planning & Development
1500 Marilla, 1FN
Dallas, TX 75201

PUBLIC MEETING / REUNIÓN PÚBLICA Sunset High School (Auditorium) Escuela Secundaria Sunset (Auditorio)

2120 Jefferson Blvd #5517, Dallas, TX 75208

TUESDAY, DEC 17, 2024 / MARTES, 17 DE DICIEMBRE DE 2024

6:00 - 7:30 PM

More Info | Más información:
bit.ly/hamptonclarendonzoning

Phone | Teléfono:
214-671-5075

Email | Correo Electrónico:
jalyn.porchay@dallas.gov

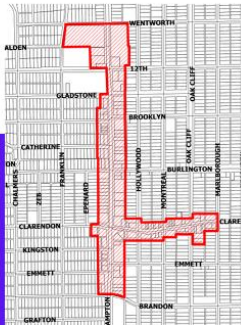

Presentation overview / Descripción general de la presentación



- Background / [Antecedentes](#)
- WOCAP Overview / [Descripción general del WOCAP](#)
- Existing Conditions / [Condiciones existentes](#)
- Form District Overview / [Descripción general del distrito basado en la forma](#)
- Proposed Zoning / [Zonificación propuesta](#)
- Next Steps / [Próximos pasos](#)



Background – Authorized Hearing Initiation

Antecedentes - Inicio de Audiencia Autorizada.



- On September 5, 2019, the City Plan Commission initiated a zoning case to determine proper zoning for an area generally along both sides of Hampton Road between Burlington Boulevard and Brandon Street and along both sides of Clarendon Drive between Marlborough Avenue and the alley west of Hampton Road containing approximately 17.45 acres
- El 5 de septiembre del 2019, la Comisión de Planificación de la Ciudad inició un caso de zonificación para determinar la zonificación adecuada para un área ubicada a lo largo de ambos lados de Hampton Road entre Burlington Boulevard y Brandon Street, y a lo largo de ambos lados de Clarendon Drive entre Marlborough Avenue y el callejón al oeste de Hampton Road, y que contiene aproximadamente 17.45 hectáreas.
- On January 19, 2023, the City Plan Commission expanded the boundaries of the Authorized hearing area to include the area generally located along both sides of Hampton Road between Wentworth Street to the north and Burlington Boulevard to the south and containing approximately 17.8 acres
- El 19 de enero de 2023, la Comisión de Planificación de la Ciudad amplió los límites del área de la audiencia autorizada para incluir el área ubicada a lo largo de ambos lados de Hampton Road entre Wentworth Street al norte y Burlington Boulevard al sur, y que contiene aproximadamente 17.8 hectáreas.



Background – Hampton-Clarendon Corridor

Antecedentes - Historia del Tranvía en Hampton-Clarendon



- Situated at the heart of West Oak Cliff, the Hampton/Clarendon Corridor Authorized Hearing (AH) area encompasses a pivotal commercial node flanking both sides of Hampton Road and Clarendon Road / Situado en el corazón de West Oak Cliff, el área de la Audiencia Autorizada (AH) del Corredor Hampton/Clarendon abarca un nodo comercial clave que se extiende a ambos lados de Hampton Road y Clarendon Road.
- Spanning approximately 35 acres, this area is home to a diverse array of small, locally owned businesses, including numerous auto-repair shops, restaurants, as well as larger format retailers such as gas stations and strip centers / Con aproximadamente 35 acres de extensión, esta área alberga una variedad diversa de pequeñas empresas de propiedad local, incluyendo numerosos talleres de reparación de automóviles, restaurantes, así como establecimientos comerciales mas grandes como estaciones de gasolina y centros comerciales.
- Although this area has existing commercial uses, many have numerous vacancies as well as barriers such as zoning which make current redevelopment or reinvestment difficult / Aunque esta área tiene usos comerciales existentes, muchos tienen numerosos edificios vacantes, así como barreras como la zonificación que dificulta la actual rehabilitación o reinversión en los edificios.



Hampton/Clarendon contains numerous small businesses. Many of these storefronts lie directly adjacent to the sidewalk, creating the possibility for a walkable commercial node, but poor pedestrian conditions present barriers to their success.



Authorized Hearings Process/ Proceso de Audiencias Autorizadas



West Oak Cliff Area Plan (WOCAP)

Plan del Área de West Oak Cliff



- Authorized hearing is part of the implementation of WOCAP, unanimously adopted by City Council on October 26, 2022. La audiencia autorizada es parte de la implementación del WOCAP, adoptada por unanimidad por el Concejo de la Ciudad el 26 de octubre de 2022.
- WOCAP provides a long-range vision for land use, urban design, transportation, mobility, infrastructure, open space, and community concerns around gentrification, displacement, and revitalization. El WOCAP proporciona una visión a largo plazo para el uso del suelo, el diseño urbano, el transporte, la movilidad, la infraestructura, los espacios abiertos y las preocupaciones de la comunidad relacionadas a la gentrificación, el desplazamiento y la revitalización.

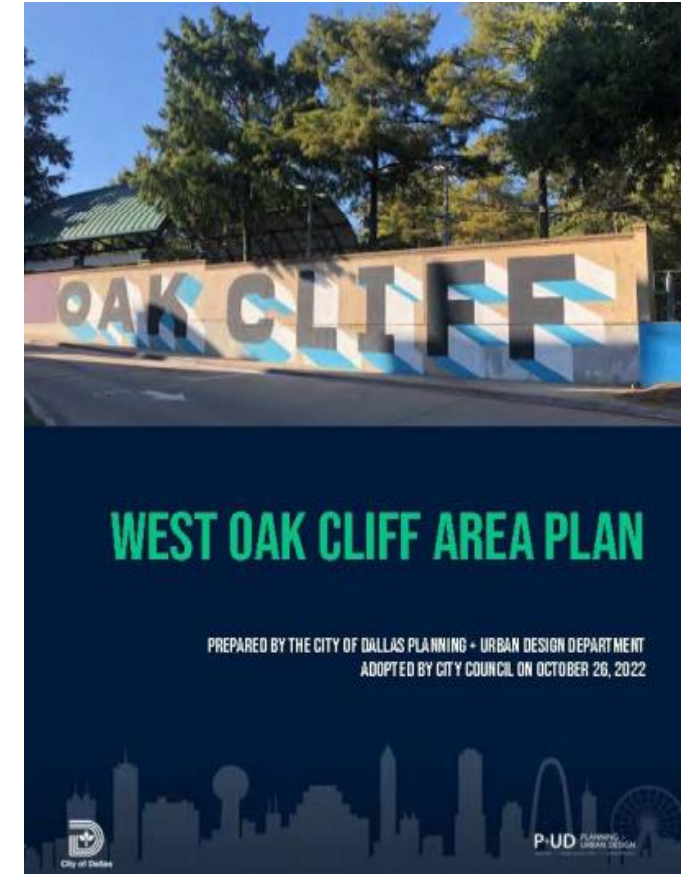

West Oak Cliff Area Plan (WOCAP)...

Plan del Área de West Oak Cliff...



- Identified several focus areas and included land use and zoning recommendations. **Identificó varias áreas de enfoque e incluyó recomendaciones de zonificación y uso de la tierra.**
- Had extensive community engagement with over 7,500 touch points with the community. **Tuvo una amplia participación comunitaria con más de 7,500 puntos de contacto con la comunidad.**



TOTAL ENGAGEMENT BY THE NUMBERS

14	Total Bilingual Public Meetings
844	Total Bilingual Surveys Completed
952	Total Attendance at City-Led Meetings
582	Total Attendance at Online Meetings
370	Total Attendance at In-Person Meetings
15	Other Touch Point Meetings
290	Comments on Social Pinpoint Maps
17,796	Visits to Social Pinpoint Website
5,998	Unique online users
469	Unique Stakeholders

7,794

TOTAL TOUCH POINTS



WOCAP Planning Focus Area/ Área de enfoque de planificación WOCAP

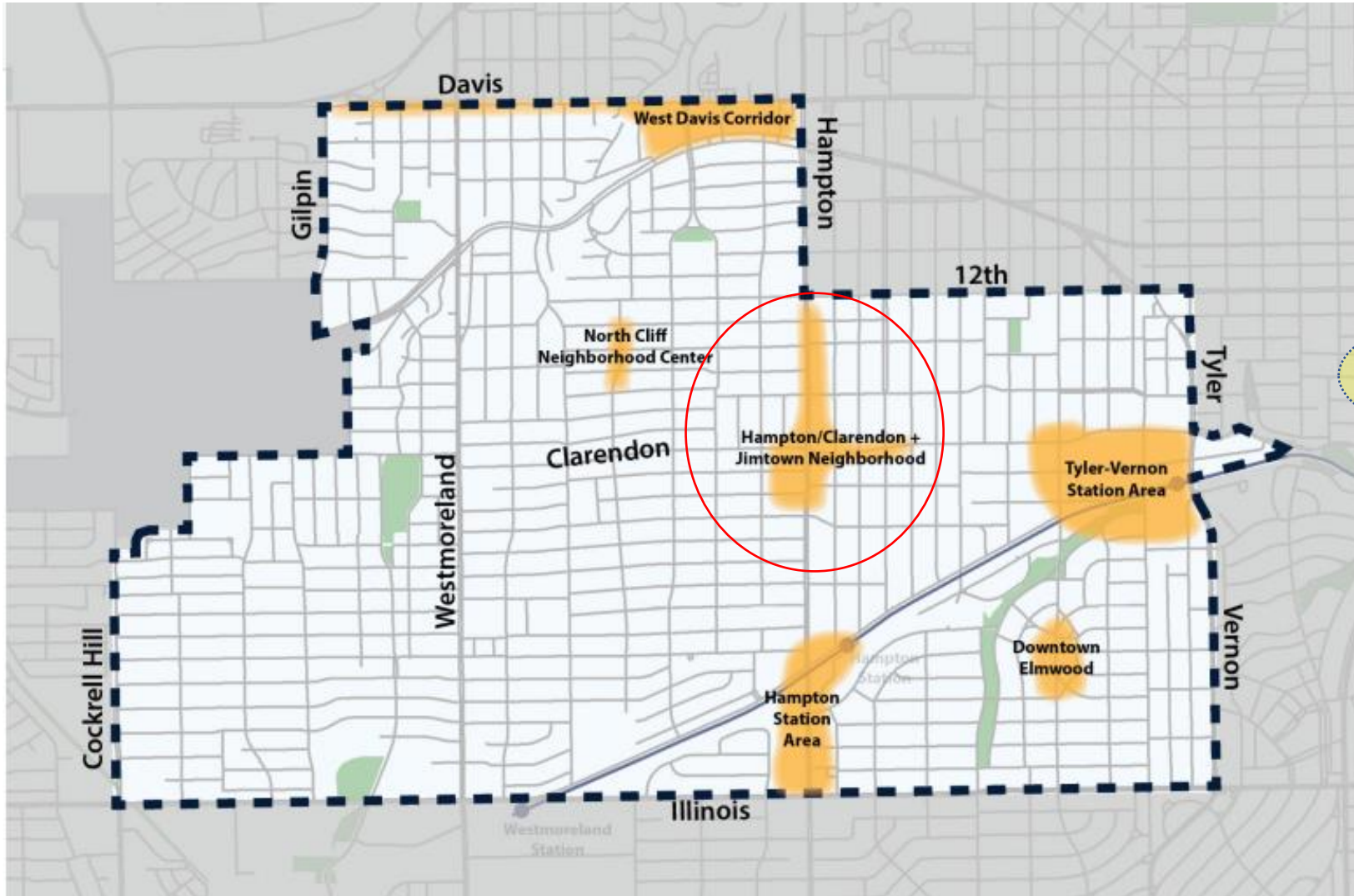

- West Davis Corridor
- North Cliff Neighborhood Center
- Hampton/Clarendon Intersection and the Jimtown Neighborhood
- Tyler-Vernon Station Area
- Downtown Elmwood
- Hampton Station Area
- Westmoreland Station Area



WOCAP Authorized Hearings/ Audiencias autorizadas por WOCAP



Five Authorized Hearings within the WOCAP Area:

5 Audiencias Autorizadas dentro del Área WOCAP

✓ Z178-142: Downtown Elmwood

• Z189-127: North Oak Cliff Neighborhood Center

• Z189-143: Edgefield/Clarendon Trolley Stop

• Z189-349: Hampton Clarendon

• Z189-240: Jimtown Neighborhood

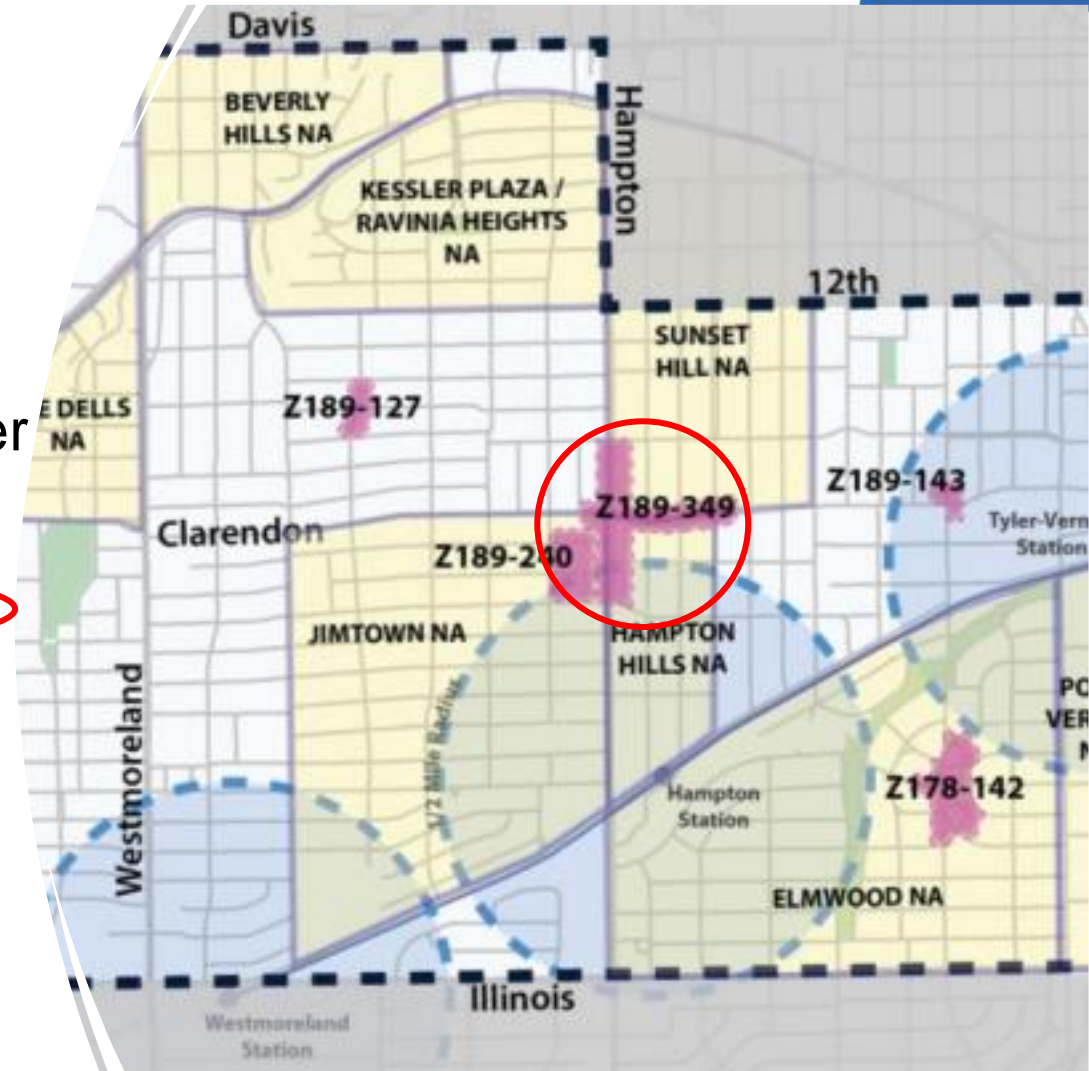

WOCAP Vision for the Commercial Areas

Visión WOCAP para las Áreas Comerciales



- Establish commercial districts that are ideal for small businesses that serve people in the neighborhood and the greater Oak Cliff area.
Establecer distritos comerciales que sean ideales para pequeñas empresas que atiendan a las personas del vecindario y del área metropolitana de Oak Cliff.
- Encourage businesses that are compatible with the surrounding neighborhoods.
Fomentar empresas que sean compatibles con los vecindarios aledaños
- Encourage adaptive reuse and renovation of existing structures.
Fomentar la reutilización adaptativa y la renovación de las estructuras existentes
- Implement traffic calming measures to make the district more walkable.
Implementar medidas para aminorar el tránsito para que el distrito sea más fácil de transitar a pie.

PLANNING GOALS



Protect existing single-family neighborhoods



Preserve natural areas and expand public parks and trails



Preserve historic buildings by encouraging renovation and reuse



Improve transportation access through better street design and suitable development around DART light rail stations



Encourage businesses that are compatible with surrounding neighborhoods



Retain current residents and attract new residents by encouraging new and affordable housing choices



Create walkable neighborhood centers that provide a variety of work, cultural, shopping and living opportunities





Z189-349 Hampton Clarendon Corridor

Z189-349 Corredor Hampton Clarendon



Photos / Fotos



Photos / Fotos



Photos / Fotos



Existing Zoning and Land Use

Zonificación y Uso del Suelo Existentes



Hampton-Clarendon area of request is comprised of approximately 35.25 acres and consists of 4 base zoning districts / El área de Hampton-Clarendon tiene aproximadamente 35.25 acres y 4 distritos de zonificación:

- **Community Retail District (CR)** includes community servicing retail, personal service, and office uses / **El Distrito de Comercio Comunitario (CR)** incluye servicios comerciales comunitarios, servicios personales y oficinas.
- **Commercial Service District (CS)** includes commercial and business serving uses that may involve outside storage, service, or display / **El Distrito de Servicios Comerciales (CS)** incluye usos comerciales y de negocios que pueden incluir almacenamiento, servicio o exhibición al aire libre.
- **Mixed Use District - 1 (MU-1)** includes moderate density retail, office, and/or multifamily residential uses in combination on single or contiguous building sites / **El Distrito de Usos Mixtos - 1 (MU-1)** incluye usos comerciales de densidad moderada, oficinas y/o usos residenciales multifamiliares en combinación edificios individuales o contiguos.
- **Regional Retail District (RR)** includes regional-serving retail, personal service, and office uses / **El Distrito de Comercio Regional (RR)** incluye servicios comerciales regionales, servicios personales y oficinas.

Hampton/Clarendon Trolley Stop Zoning Map

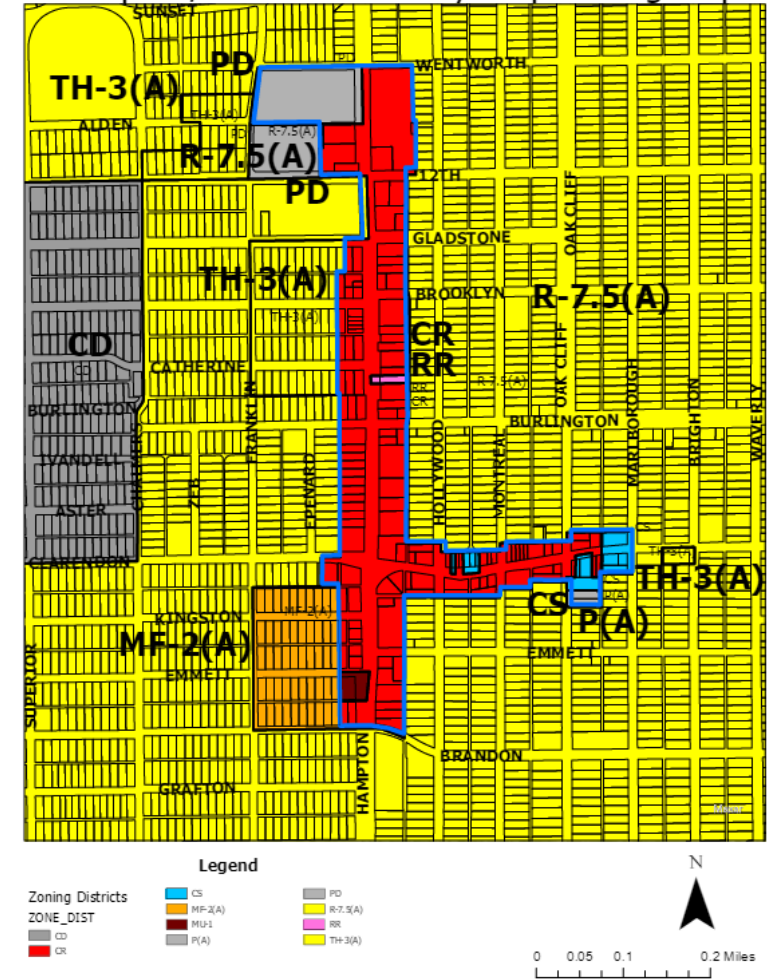

Current Land Use/ **Uso actual de la tierra**



Land Use	Count	Percent
Retail and personal service uses	66	37.5%
Auto Service	23	13.1%
Commercial and business service uses	2	1.1%
Institutional and community service uses	11	6.3%
Office	14	8.0%
Single Family	15	8.5%
Utility and public service uses	2	1.1%
Vacant Building	11	6.3%
Vacant Lot	32	18.2%
Total	176	100.0%

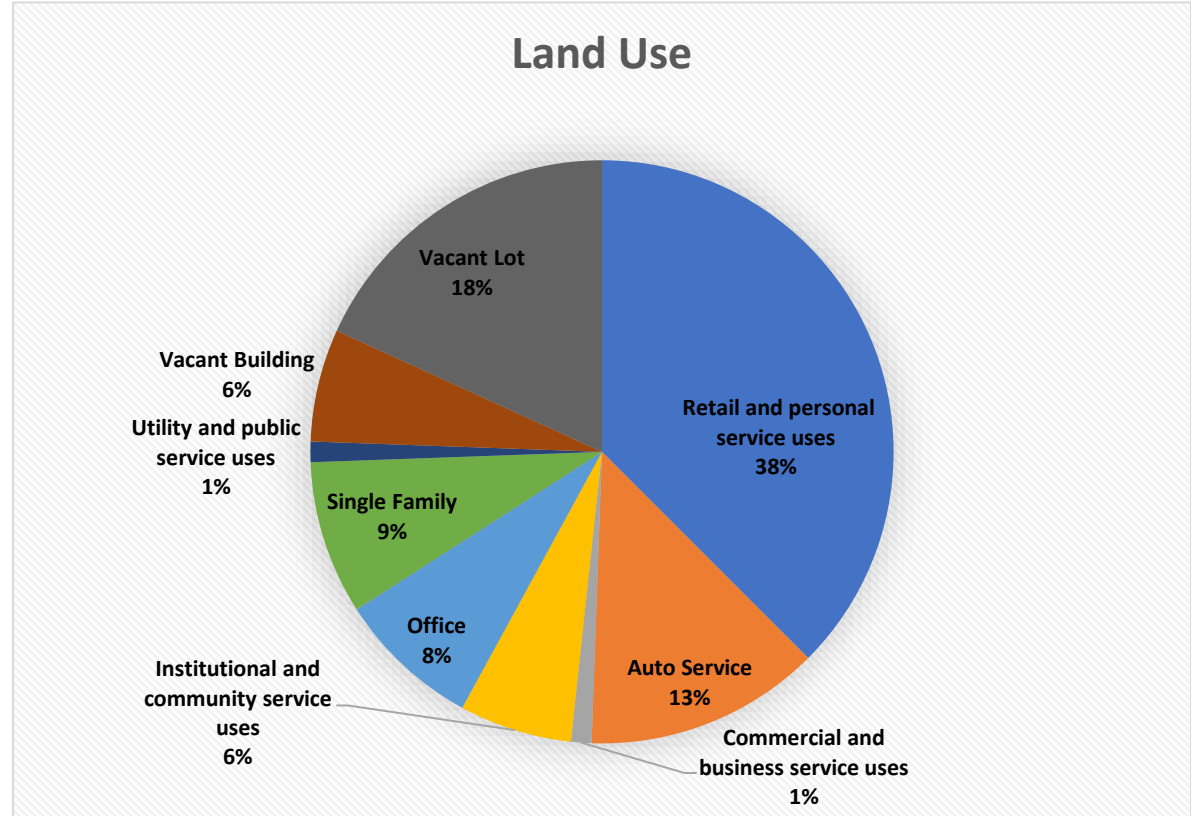

WOCAP Recommendations

Recomendaciones de WOCAP



The objective of this Authorized Hearing is to explore implementing the following recommendations of WOCAP / El objetivo de esta Audiencia Autorizada es explorar la implementación de las siguientes recomendaciones de WOCAP:

- Amend existing zoning (CR, MU-1, CS, and P(A)) to allow for mixed-use development along Hampton Road (between Wentworth and Brandon) and Clarendon (between Hampton and Marlborough) / Modificar la zonificación existente (CR, MU-1, CS y P(A)) para permitir el desarrollo de uso mixto a lo largo de Hampton Road (entre Wentworth y Brandon) y Clarendon (entre Hampton y Marlborough)
- Explore form-based zoning districts for walkable urban form, including activated facades and wide sidewalks / Explorar distritos de zonificación basados en un sistema de forma urbana peatonal e incluir fachadas activadas y aceras amplias
- Promote pedestrian-oriented design, minimizing vehicular-pedestrian conflict points, curb cuts, and parking locations. Explore prohibiting new drive-thru establishments / Promover el diseño orientado al peatón, minimizar los puntos de conflicto entre vehículos y peatones, cortes de acera y ubicaciones de estacionamiento. Explorar la prohibición de nuevos establecimientos con servicio por ventana
- Ensure proposed rezoning considers residential proximity slopes, setbacks, and landscaping to minimize impact on adjacent single-family properties / Asegurar que la rezonificación propuesta considere las pendientes de proximidad residencial, los espacios y el paisajismo para minimizar el impacto en las propiedades unifamiliares adyacentes
- Permit small multifamily developments (12 units or smaller) and townhomes within the designated areas / Permitir pequeños desarrollos multifamiliares (12 unidades o menos) y casas adosadas dentro de las áreas designadas.



Zoning Proposal/Propuesta de Zonificación



- Staff recommends **Form-Based Zoning** for the district/**El personal recomienda la zonificación basada en formularios para el distrito**
- Form-Based Code (FBC) is a method of zoning where the codes and regulations focus on addressing the relationship between building facades and the public realm, form and mass of buildings relative to one another, and the scale and types of streets and blocks\ **El Código basado en la forma (FBC) es un método de zonificación en el que los códigos y regulaciones se centran en abordar la relación entre las fachadas de los edificios y el ámbito público, la forma y la masa de los edificios entre sí, y la escala y los tipos de calles y cuadras.**
- Unlike the Euclidean zoning that primarily regulates allowable use, FBC emphasizes the compatibility of the buildings with their surroundings, while letting the mix of actual activities in them be more eclectic\ **A diferencia de la zonificación euclidiana que regula principalmente el uso permitido, FBC enfatiza la compatibilidad de los edificios con su entorno, al tiempo que permite que la combinación de actividades reales en ellos sea más ecléctica.**

CHAPTER 51A
ARTICLE XIII: FORM DISTRICTS
CITY OF DALLAS

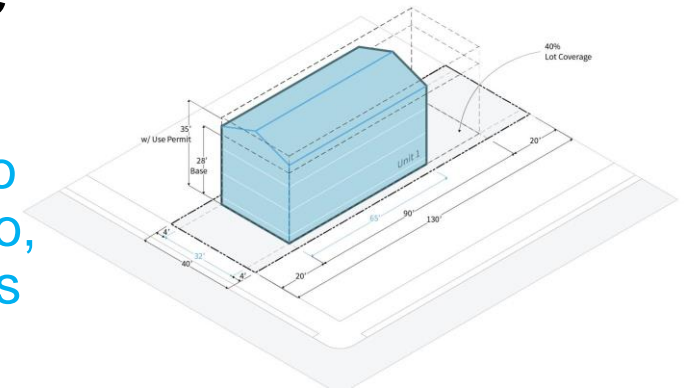
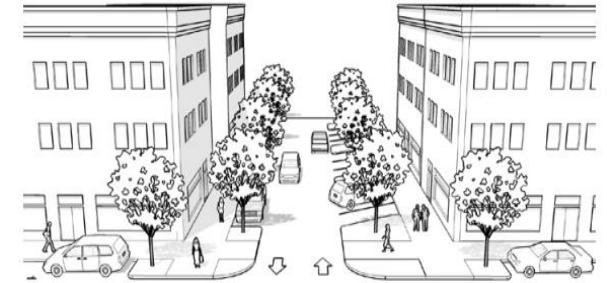

Form Based vs. Traditional Zoning \ Zonificación basada en formularios vs. zonificación tradicional



Traditional Zoning \ Zonificación Tradicional	Form-Based Code \ Código basado en formularios
Focuses on how a buildings is being used \ Se centra en cómo se utiliza un edificio.	Focuses on the form of a building more than its function \ Se centra más en la forma de un edificio que en su función.
Reserves each “zone” or designated area of land for a specific use \ Reserva cada “zona” o área de tierra designada para un uso específico	Zoning is based on context \ La zonificación se basa en el contexto.
Rigid and inflexible \ Rígido e inflexible	Addresses unforeseen issues, like design standards, that traditional codes do not \ Aborda cuestiones imprevistas, como estándares de diseño, que los códigos tradicionales no abordan.
Regulates use, density, and level of activity (intensity) \ Regula el uso, la densidad y el nivel de actividad (intensidad)	Affect everything from the character of a building, to the size of the street it is on, and even the type and size of the signage \ Afecta todo, desde el carácter de un edificio hasta el tamaño de la calle en la que se encuentra e incluso el tipo y tamaño de la señalización.



Zoning Recommendations\

Recomendaciones de zonificación



- Aligns with WOCAP's goal of transforming the node into a neighborhood-scale mixed-use district that is pedestrian friendly\ Se alinea con el objetivo de WOCAP de transformar el nodo en un distrito de uso mixto a escala de vecindario que sea amigable para los peatones.
- No minimum acreage required for WMU zoning\ No se requiere superficie mínima para la zonificación de WMU
- WMU-3 allows a variety of housing types, nonresidential uses, and urban design standards to ensure the desired urban form\ WMU-3 permite una variedad de tipos de vivienda, usos no residenciales y estándares de diseño urbano para garantizar la forma urbana deseada.

https://codelibrary.amlegal.com/codes/dallas/latest/dallas_tx/0-0-0-93607



Form District Development Types

Tipos de desarrollo de distritos



	Mixed Use Shopfront	Single-Story Shopfront	General Commercial	Apartment	Townhouse Stacked	Townhouse	Manor House	Single-Family House	Civic Building	Open Space Lot
District	Mu	Ss	Gc	Apt	Ts	Th	Mh	Sf	Civ	O
Walkable Urban Mixed Use (WMU)										
Low (WMU-3, WMU-5)	■	■	■	■	■	■	■		■	■
Medium (WMU-8, WMU-12)	■		■	■	■	■			■	■
High (WMU-20, WMU-40)	■		■	■					■	■
Walkable Urban Residential (WR)										
Low (WR-3, WR-5)		■ *		■	■	■	■		■	■
Medium (WR-8, WR-12)				■	■	■			■	■
High (WR-20, WR-40)				■					■	■
Residential Transition (RTN)						■	■	■	■	■
Shopfront (-SH) Overlay over any WMU or WR district	■	■							■	■

See Section [51A-13.304](#), “Development Types.”



WMU-3 Development Types & Uses\

Tipos y usos de desarrollo de WMU-3



Development Types/ Tipos de desarrollo

- Mixed-Use Shopfront
- Single-Story Shopfront
- General Commercial
- Apartments (ground floor retail/office)
- Townhouse
- Townhouse stacked
- Manor House
- Civic Building
- Open Space

Principal Uses\Usos principales

- Office
- Retail
- Service and Entertainment
- Commerce
- Fabrication
- Residential
- Civic
- Place of Worship

**New single-family houses are not allowed/ No se permiten viviendas unifamiliares nuevas*



Development Type Examples

Ejemplos de tipos de desarrollo



Manor House



Mixed-Use Shopfront



Single-Story Shopfront

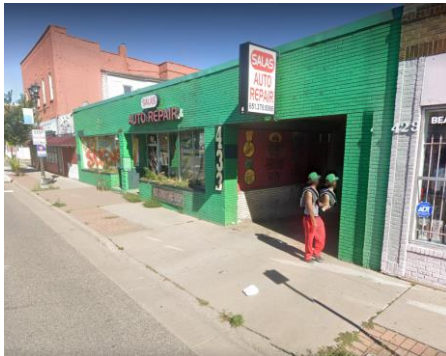

Townhouse Stacked



Permitted Uses in WMU-3 \ Usos permitidos en WMU-3



Principal Use	Use Category
Office	Medical
	Office
Retail	Drive-thru facility
	Restaurant or Bar
	Retail sales
Service and Entertainment	Vehicle sales
	Commercial amusement (inside)
	Indoor recreation
	Personal service
Commerce	Animal care
	Commercial parking
	Passenger terminal/ Helistop
	Overnight lodging
	Self-service storage
Fabrication	Light manufacturing
	Research and development
	Vehicle service

Principal Use	Use Category
Residential	Single-family living
	Multifamily living
	Group living
	Community service
Civic	<i>Museum, library</i>
	Day care
	Educational
	Government service,
	<i>Detention center, jail, or prison</i>
Place of Worship	Park or Open space
	Social service
	Transit station
	Utilities
	Place of Worship



What we've heard (Community Desires)

Lo que hemos escuchado (deseos de la comunidad)



- Strong support for adaptive reuse of existing structures./ **Fuerte apoyo para la reutilización adaptativa de las estructuras existentes**
- Minimize displacement/gentrification/ **Minimizar el desplazamiento/gentrificación**
- We're excited for this! When Will it be completed? / **¡Estamos emocionados por esto! ¿Cuándo estará terminado?**
- Support for improving walkability in the neighborhood/ **Apoyo para mejorar la transitabilidad del barrio**
- Parking is an issue for business owners/ **El estacionamiento es un problema para los dueños de negocios**



What we've heard (Community Desires)

Lo que hemos escuchado (deseos de la comunidad)



- The Neighborhood is perfect the way it is. We do not want change. / El vecindario es perfecto tal como está. No queremos cambios.
- Strong support for protecting single-family neighborhoods/ Fuerte apoyo a la protección del barrio unifamiliar.
- We prefer an overlay to prevent townhomes in the Hampton Corridor. / Preferimos una superposición para prevenir las casas adosadas en el Corredor de Hampton.
- Some residents do not want multifamily housing/land developers in this area but want affordable housing / Algunos residentes no quieren viviendas multifamiliares/ desarrolladores de terrenos en esta área, pero quieren viviendas asequibles.
- I'm optimistic about the plans for walkability, wider sidewalks, and "multifamily developments (12 units or smaller) and townhomes." What I ask is that development be aesthetically pleasing / Soy optimista sobre los planes para mejorar la caminabilidad, las aceras más amplias y "desarrollos multifamiliares (12 unidades o menos) y casas adosadas." Lo que pido es que el desarrollo sea estéticamente agradable.



Community Concerns/Preocupaciones de la comunidad



- Demolition of existing homes for multifamily/townhomes/ Demolición de viviendas existentes para casas multifamiliares/adosadas.
- New development causing more traffic and increasing property taxes/ Nuevo desarrollo que causa más tráfico y aumenta los impuestos a la propiedad.
- Concerns about replating into larger lots for missing middle housing/ Preocupaciones sobre la reubicación en lotes más grandes para viviendas intermedias faltantes

We don't want
this!!! / ¡No
queremos esto!



Community Concerns / Preocupaciones de la comunidad



- New development causing more traffic and increasing property taxes./ El nuevo desarrollo está causando más tráfico y aumentando los impuestos a la propiedad
- Misconception that WOCAP changed zoning in West Oak Cliff./ Concepto erróneo de que WOCAP cambió la zonificación en West Oak Cliff
- Misconceptions that apartments brings in bad people and increases crime./ Conceptos erróneos de que los apartamentos traen a malas personas y aumentan el crimen.
- Replacement of Hispanic culture./ Reemplazo de la cultura hispana



How Staff Makes Recommendations/ Cómo el personal hace recomendaciones.



- Community input / [Aportes de la comunidad](#)
- City-adopted plans / [Planes adoptados por la ciudad](#)
- City policies and priorities / [Políticas y prioridades de la ciudad](#)
- Planning best practices / [Mejores prácticas de planificación.](#)
- Public interest (health and safety) / [Interés público \(salud y seguridad\)](#)



Staff recommendations are not about aesthetics: / [Las recomendaciones del personal no se trata de estética:](#)

- ❖ Functionality / [Funcionalidad](#)
- ❖ Viability of businesses / [Viabilidad de las empresas](#)
- ❖ Mobility and connectivity / [Movilidad y conectividad](#)
- ❖ Safety / [Seguridad](#)



First Proposal (Draft)

Primera Propuesta (Borrador)



Clarendon Drive (Hollywood Ave – Marlborough Ave)

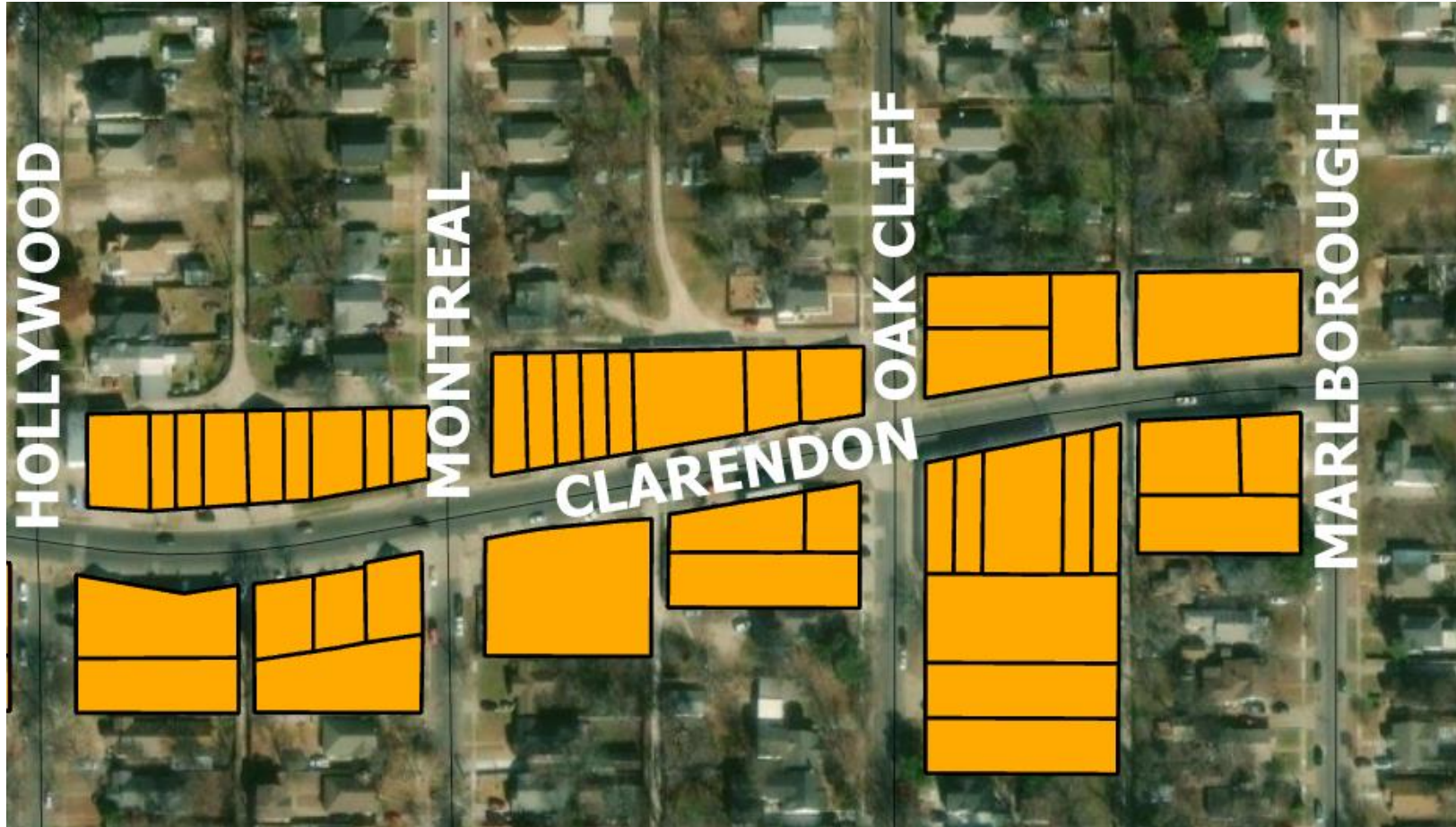

Legend

- PD, Planned Development
- CR (Community Retail)
- WMU-3 (Proposed)





Hampton Road (Burlington to the North, Brandon to the south, Hollywood to the East, Epenard to the West



- Legend
- PD, Planned Development
 - CR (Community Retail)
 - Shopfront Overlay (Proposed)
 - WMU-3 (Proposed)



Hampton Road (Wentworth to the north, Burlington to the South)

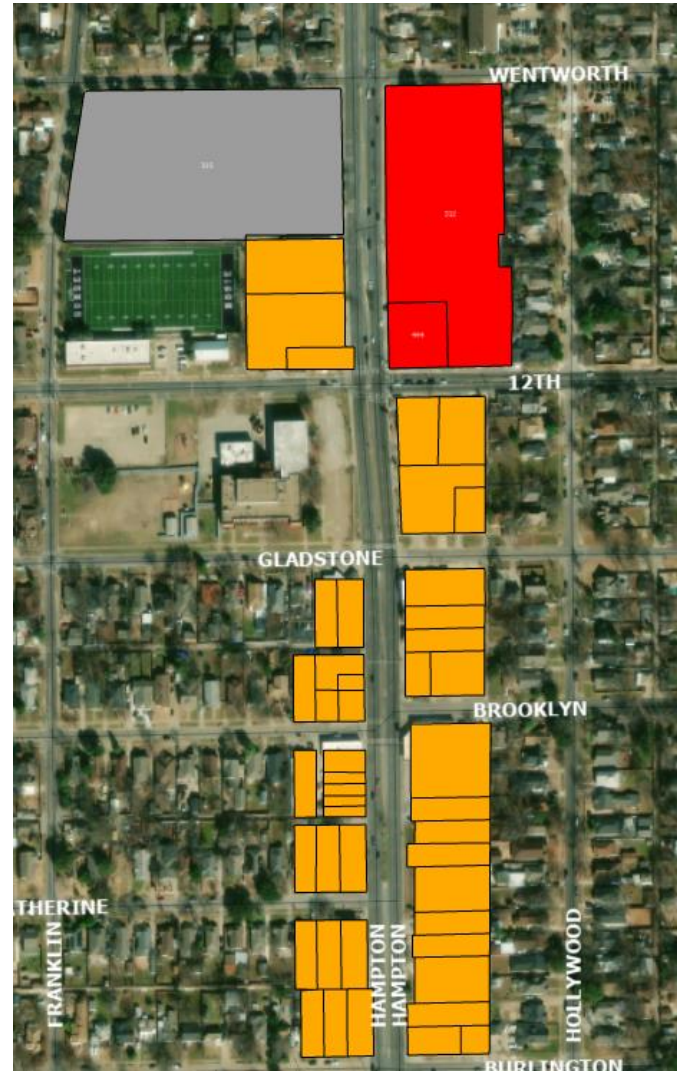

Legend

- PD, Planned Development
- CR (Community Retail)
- WMU-3 (Proposed)



Development Standards Highlights\

Aspectos destacados de los estándares de desarrollo



1. Setbacks\ Contratiempos

- Front yard/primary street frontage: Min/Max 5/15 ft
Patio delantero/frente a la calle principal: mín./máx. 5/15 pies
- Side and rear yard: 5 feet (10ft abutting Residential District)\
Patio lateral y trasero: 5 pies (10 pies contiguos al distrito residencial)
- Lot Coverage: 100%-60% depending on development type
Cobertura del lote: 100% -60% dependiendo del tipo de desarrollo



2. Height\ Altura

- Max building height is 50 feet/3.5 stories\ La altura máxima del edificio es de 50 pies/3,5 pisos.
- Height bonuses may be provided for Mixed Income Housing Development Bonus (MIHDB)\
Se pueden otorgar bonificaciones de altura para el Bono de Desarrollo de Vivienda para Ingresos Mixtos (MIHDB)
- 3:1 Residential Proximity Slope (RPS) apply
Se aplica pendiente de proximidad residencial (RPS) de 3:1





3. Landscaping\ Paisajismo

- As per Article X (Landscape and tree ordinance) of the Dallas development code
Según el Artículo X (Ordenanza de paisaje y árboles) del código de desarrollo de Dallas

4. Open Space\ Espacio abierto

- At least 8% of net land area of a site must be provided as open space
Al menos el 8% de la superficie neta de un sitio debe destinarse a espacios abiertos.

5. Screening\ Poner en pantalla

- All HVAC equipment, mechanical devices, and dumpsters must be screened from view from adjacent streets and properties.

Todos los equipos HVAC, dispositivos mecánicos y contenedores de basura deben estar protegidos de la vista desde calles y propiedades adyacentes.



Development Standards \ Estándares de desarrollo



Standard	Existing: CR	Staff Recommendation: WMU-3
Front setback	15' min	Primary street: 5' min / 15' max
Street frontage, primary street*	-	Primary street: 70% min
Parking setback		Primary street: 30' min Abutting multifamily, nonresidential district, alley: 5' min
Side setback	20' - adjacent to or across alley from R(A), D(A), TH(A), CH, MF(A) 0 feet in all other cases	Abutting multifamily, non- residential district: 0' or 5' min Abutting alley: 5' min
Rear Setback	20' - adjacent to or across alley from R(A), D(A), TH(A), CH, MF(A) 0 feet in all other cases	Abutting nonresidential district: 0' or 5' min Abutting alley: 5' min
Rear setback	2.0 FAR overall 0.75 office/retail 0.5 retail	
Height	1 story min 4 stories/54' max <small>¹.Any portion of structure over 28 feet may not be located above a Residential Proximity Slope (RPS)</small>	1 story min 3.5 stories / 50' max
Story height	80%	Ground story: 10' min / 15' max Upper story: 10' min / 15' max
Lot coverage	60% maximum lot coverage ¹ . Above ground parking structures are included ² . Surface parking lots and underground parking structures are not	80% max
Lot size	No minimum lot size	No minimum

Standard	Existing: CR	Staff Recommendation: WMU-3
Front setback	15' min	Primary street: 5' min / 15' max
Transparency		Ground story, primary street façade: 30% Upper story, primary street façade: 20%
Entrance		Required on primary street Entrance spacing: None
	Dwelling Unit Density	
Floor Area Ratio	0.5 for office uses 0.75 for all uses combined	
Blank wall area	Proximity slope Visual intrusion	Primary street: 30' max
Special standards	Development Impact Review (DIR) required if estimated trip greater than 6000 trips per day and 500 trips per acre per day Visual Intrusion No balcony or opening facing a R(A), D(A), TH(A), CH, MF- 1(A)(SAH), MF- 2(A)(SAH) district may be above the RPS	Proximity slope
Landscaping	Article X	Article X



Residential Proximity Slope (RPS)

Pendiente de Proximidad Residencial (RPS)



- Under the existing zoning, CR, building can be constructed as high as 54 feet or four stories, but adjacent residences are protected a 3:1 RPS\ Según la zonificación existente, CR, el edificio se puede construir a una altura de hasta 54 pies o cuatro pisos, pero las residencias adyacentes están protegidas con un RPS de 3:1.
- The maximum building height in a WMU-3 form district is 50 feet or 3.5 stories; adjacent residences protected by 3:1 RPS\ La altura máxima de construcción en un distrito de forma WMU-3 es de 50 pies o 3,5 pisos; residencias adyacentes protegidas por 3:1 RPS
- Limit building heights to no more than 3 stories\ Limite la altura de los edificios a no más de 3 pisos.

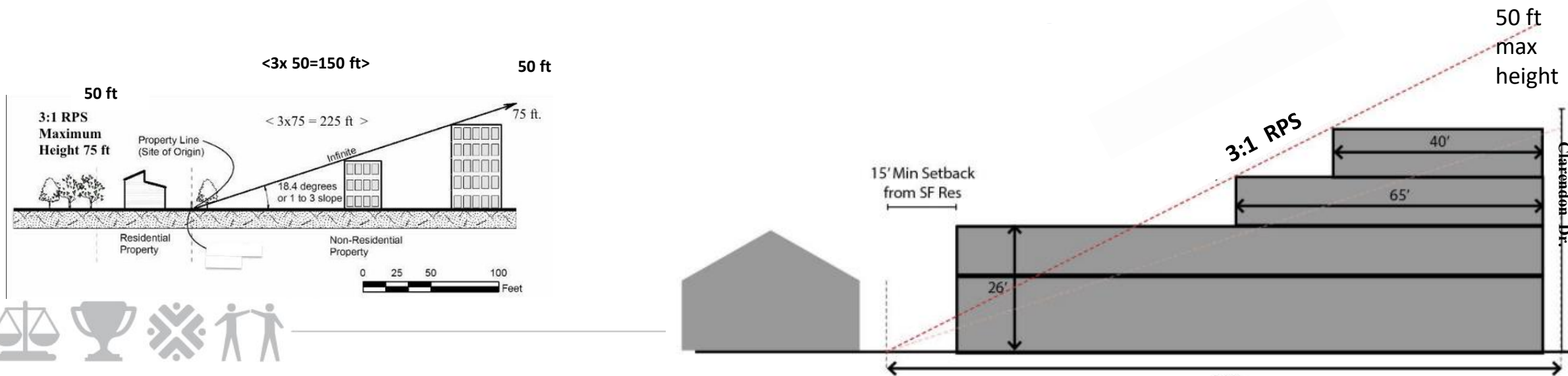

Shopfront Overlay / Superposición de escaparate



- Shopfront (-SH) overlay is intended to create pedestrian shopping street frontages with development types that support active uses. / La superposición de fachada comercial (-SH) está destinada a crear frentes de calles comerciales peatonales con tipos de desarrollo que apoyen usos activos.
- Shopfront (-SH) Overlay may be applied over any WMU and is intended to accommodate a limited set of development types. / La superposición de fachada comercial (-SH) puede aplicarse sobre cualquier WMU y está destinada a acomodar un conjunto limitado de tipos de desarrollo.
- Where a -SH overlay designation is applied, the standards for a mixed use or single-story shopfront development type apply to at least the first 30 feet of the building measured inward from the street-facing facade. / Donde se aplica una designación de superposición -SH, los estándares para un tipo de desarrollo de fachada comercial de uso mixto o de una sola planta se aplican a al menos los primeros 30 pies del edificio medidos hacia el interior desde la fachada que da a la calle.
- Any street designated with a -SH overlay is a primary street. / Cualquier calle designada con una superposición -SH es una calle principal.
- The boundaries are not required to follow lot lines or match parcel boundaries. / Los límites no están obligados a seguir las líneas de los lotes ni a coincidir con los límites de las parcelas.



Public Realm Enhancements\ Mejoras en el ámbito público



- Changing zoning to WMU-3 form district could result in parking reduction\ Cambiar la zonificación al distrito de forma WMU-3 podría resultar en una reducción del estacionamiento
- Reconfiguring and redesigning the public ROW provides additional on-street parking that can be used to meet permitting requirements\ La reconfiguración y el rediseño del derecho de vía público proporciona estacionamiento adicional en la calle que se puede utilizar para cumplir con los requisitos de permisos.

Long-Term Goals

- Traffic calming\calmar el tráfico
- Sidewalk enhancements\Mejoras en las aceras
- Service parking in the back\Aparcamiento de servicio en la parte trasera.
- Potential art opportunities\ Posibles oportunidades artísticas



Non-Conforming Structures\ Estructuras no conformes



Per the code, if a structure becomes non-conforming with a zoning change: \ De acuerdo con el código, si una estructura se vuelve no conformante debido a un cambio de zonificación:

- Existing structures not required to conform retroactively unless **major renovations** are made to the buildings. / Las estructuras existentes no están obligadas a conformarse de manera retroactiva a menos que se realicen renovaciones importantes en los edificios.
- **Major renovation** means a building permit or series of building permits for the reconstruction, alteration or modification of building that increases the floor area by at least 35 %\ "Renovación importante" significa un permiso de construcción o una serie de permisos de construcción para la reconstrucción, alteración o modificación de un edificio que aumenta el área de piso en al menos un 35%.
- Total additions to existing non-conforming structures less than or equal to 35% of the original floor area existing as of [date of passage] must comply with the use and placement requirements and the height and elements requirements in Section 51A-13.304 for the development type.\ Las adiciones totales a las estructuras no conformes existentes, que sean menores o iguales al 35% del área de piso original existente a partir de [fecha de aprobación], deben cumplir con los requisitos de uso y ubicación, así como con los requisitos de altura y elementos en la Sección 51A-13.304 para el tipo de desarrollo.





RULES /REGLAS

1. Write your questions on the comments card and give it to staff. \ **Escriba sus preguntas en la tarjeta de comentarios y déjela al personal.**
2. Questions should be pertinent/relevant to the topic of discussion (Zoning). \ **Las preguntas deben ser pertinentes/relevantes al tema de discusión (Zonificación)**
3. No personal attacks on staff, community leader, a resident, and elected or appointed official / **No se permiten ataques personales contra el personal, líderes comunitarios, residentes y funcionarios electos o designados.**
4. No questions about the WOCAP planning process as that process is already completed and we are now on the plan implementation. \ **No se permiten preguntas sobre el proceso de planificación de WOCAP, ya que ese proceso ya está completo y ahora estamos en la implementación del plan.**



Next Steps\Próximos pasos



1. Fourth community meeting to review the proposal and feedback from property the community and scenario testing (more meetings optional) \ Cuarta reunión comunitaria para revisar la propuesta y los comentarios de la comunidad y la prueba de escenarios (más reuniones opcionales)
2. City Plan Commission (CPC) public hearing (December - January)\ Audiencia pública de la Comisión de Planificación de la Ciudad (CPC) (Diciembre - Enero)
3. City Council Vote (TBD)\ Votación del Concejo Municipal (por determinar)

Jalyn Porchay, AICP
Candidate
Senior Planner
Planning & Development
Department
City of Dallas

Jalyn.porchay@dallas.gov
Tel. 214-671-5075

Follow project updates at: \Siga las actualizaciones del proyecto en:
<https://dallascityhall.com/departments/pnv/Pages/HamptonClarendonAH.aspx>

