



City of Dallas

Hampton Clarendon Authorized Hearing

**Audiencia Autorizada del Hampton
Clarendon**

Z189-349

**Fourth Community Meeting (Zoning
Consensus)**

**Cuarta Reunión Comunitaria (Consenso sobre
Zonificación)**

December 17, 2024

17 de diciembre de 2024

Jalyn Porchay AICP Candidate, Sr.
Planner
Planning & Development Department
City of Dallas

Agenda



1. Welcome/Introduction/**Bienvenida/Introducción**
2. Recap of Previous Meeting/**Resumen de la reunión anterior**
3. Community Input/**Opinión de la comunidad**
4. Zoning Ideas – / **Propuesta de zonificación – P&D**
5. Q & A / **Preguntas y Respuestas**
6. Next Steps / **Próximos pasos**
7. Adjourn / **Clausura de la reunión**

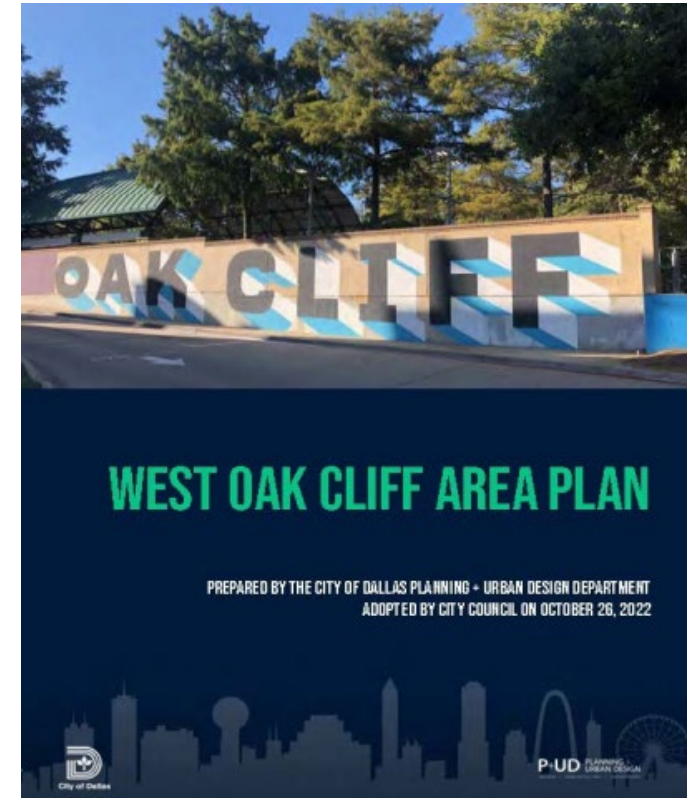

Presentation overview / Descripción general de la presentación



- Background / [Antecedentes](#)
- WOCAP Overview / [Descripción general del WOCAP](#)
- Existing Conditions / [Condiciones existentes](#)
- Form District Overview / [Descripción general del distrito basado en la forma](#)
- Proposed Zoning / [Zonificación propuesta](#)
- Next Steps / [Próximos pasos](#)



Background – Authorized Hearing Initiation

Antecedentes - Inicio de Audiencia Autorizada.



- September 5, 2019: The City Plan Commission (CPC) recommended a city-initiated review of the zoning for an area generally along Hampton Rd between Burlington Blvd and Brandon St and along Clarendon Dr between Marlborough Ave and the alley west of Hampton Rd. Apprx 17.45 acres
- 5 de septiembre del 2019: la Comisión de Planificación de la Ciudad (CPC) inició un reviso de la zonificación para un área ubicada a lo largo de Hampton Rd entre Burlington Blvd y Brandon St, y a lo largo de Clarendon Dr entre Marlborough Ave y el callejón al oeste de Hampton Rd,. Aprx 17.45 hectáreas.
- January 19, 2023: the CPC expanded the boundaries of the area to include the area generally located along both sides of Hampton Rd between Wentworth St to the north and Burlington Blvd to the south. Apprx 17.8 acres
- El 19 de enero de 2023, la CPC amplió los límites del área para incluir el área ubicada a lo largo de Hampton Rd entre Wentworth St al norte y Burlington Blvd al sur. Aprx 17.8 hectáreas.

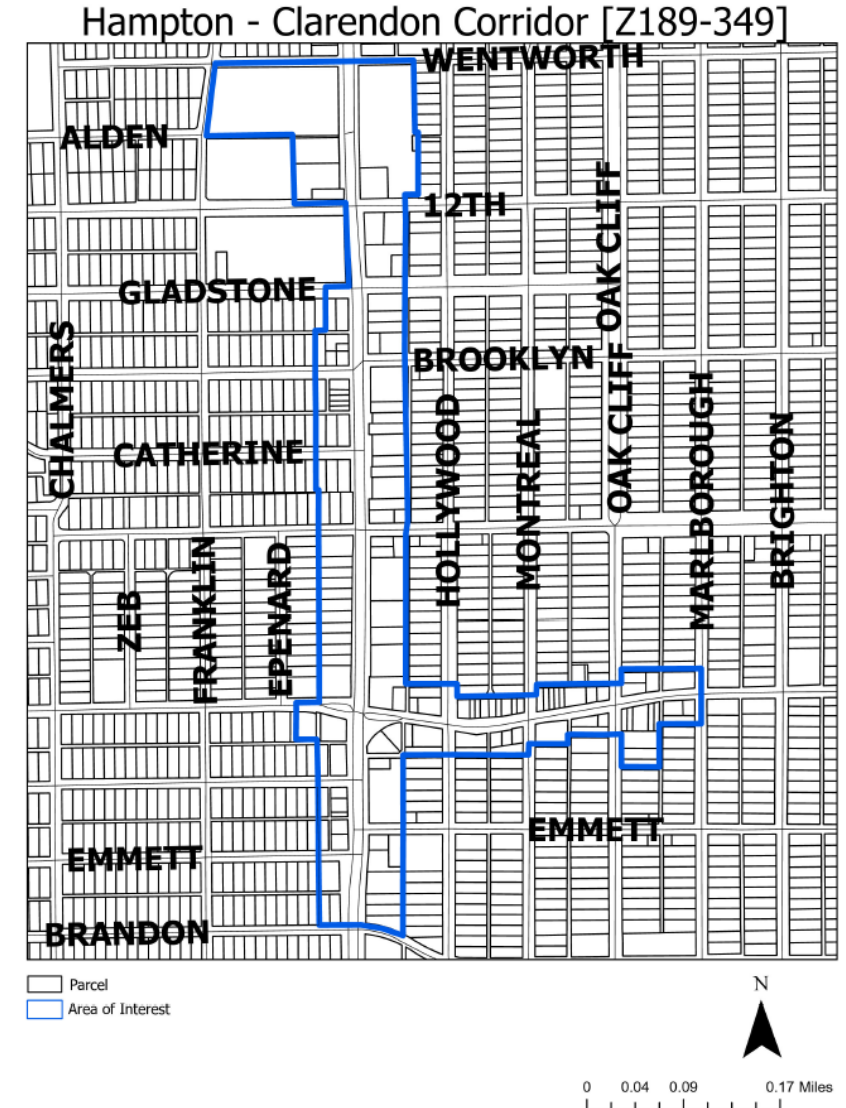

Authorized Hearings Process / Proceso de Audiencias Autorizadas



Research, Analysis & Stakeholder Engagement / Investigación, análisis y participación de las partes interesadas

Kick-off Project meeting / Reunión de lanzamiento del proyecto

1st Community Meeting- Zoning Concepts / 1ra Reunión Comunitaria-Conceptos de Zonificación

2nd Community Meeting - Zoning Recommendations / Segunda reunión comunitaria: recomendaciones de zonificación

City Council Public Hearing / Audiencia pública del Concejo de la Ciudad

City Plan Commission Public Hearing / Audiencia pública de la Comisión de Planificación

Additional Meetings (as needed) / Reuniones adicionales (según sea necesario)

3rd Community meeting - Zoning Consensus / 3ra Reunión Comunitaria-Consenso de Zonificación



West Oak Cliff Area Plan (WOCAP)

Plan del Área de West Oak Cliff



- Authorized hearing is part of the implementation of WOCAP, unanimously adopted by City Council on October 26, 2022. La audiencia autorizada es parte de la implementación del WOCAP, adoptada por unanimidad por el Concejo de la Ciudad el 26 de octubre de 2022.
- WOCAP provides a long-range vision for land use, urban design, transportation, mobility, infrastructure, open space, and community concerns around gentrification, displacement, and revitalization. El WOCAP proporciona una visión a largo plazo para el uso del suelo, el diseño urbano, el transporte, la movilidad, la infraestructura, los espacios abiertos y las preocupaciones de la comunidad relacionadas a la gentrificación, el desplazamiento y la revitalización.

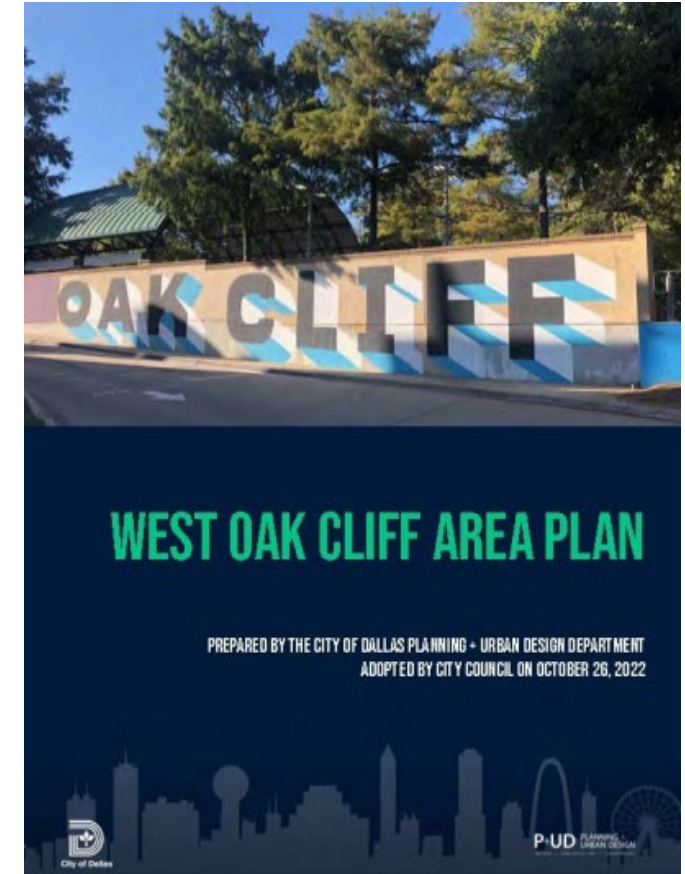

West Oak Cliff Area Plan (WOCAP)...

Plan del Área de West Oak Cliff...



- Identified several focus areas and included land use and zoning recommendations. **Identificó varias áreas de enfoque e incluyó recomendaciones de zonificación y uso de la tierra.**
- Had extensive community engagement with over 7,500 touch points with the community. **Tuvo una amplia participación comunitaria con más de 7,500 puntos de contacto con la comunidad.**



TOTAL ENGAGEMENT BY THE NUMBERS

14	Total Bilingual Public Meetings
844	Total Bilingual Surveys Completed
952	Total Attendance at City-Led Meetings
582	Total Attendance at Online Meetings
370	Total Attendance at In-Person Meetings
15	Other Touch Point Meetings
290	Comments on Social Pinpoint Maps
17,796	Visits to Social Pinpoint Website
5,998	Unique online users
469	Unique Stakeholders

7,794

TOTAL TOUCH POINTS



WOCAP Authorized Hearings/ Audiencias autorizadas por WOCAP



Five Authorized Hearings within the WOCAP Area:

5 Audiencias Autorizadas dentro del Área WOCAP

✓ Z178-142: Downtown Elmwood

• Z189-127: North Oak Cliff Neighborhood Center

• Z189-143: Edgefield/Clarendon Trolley Stop

• Z189-349: Hampton Clarendon

• Z189-240: Jimtown Neighborhood

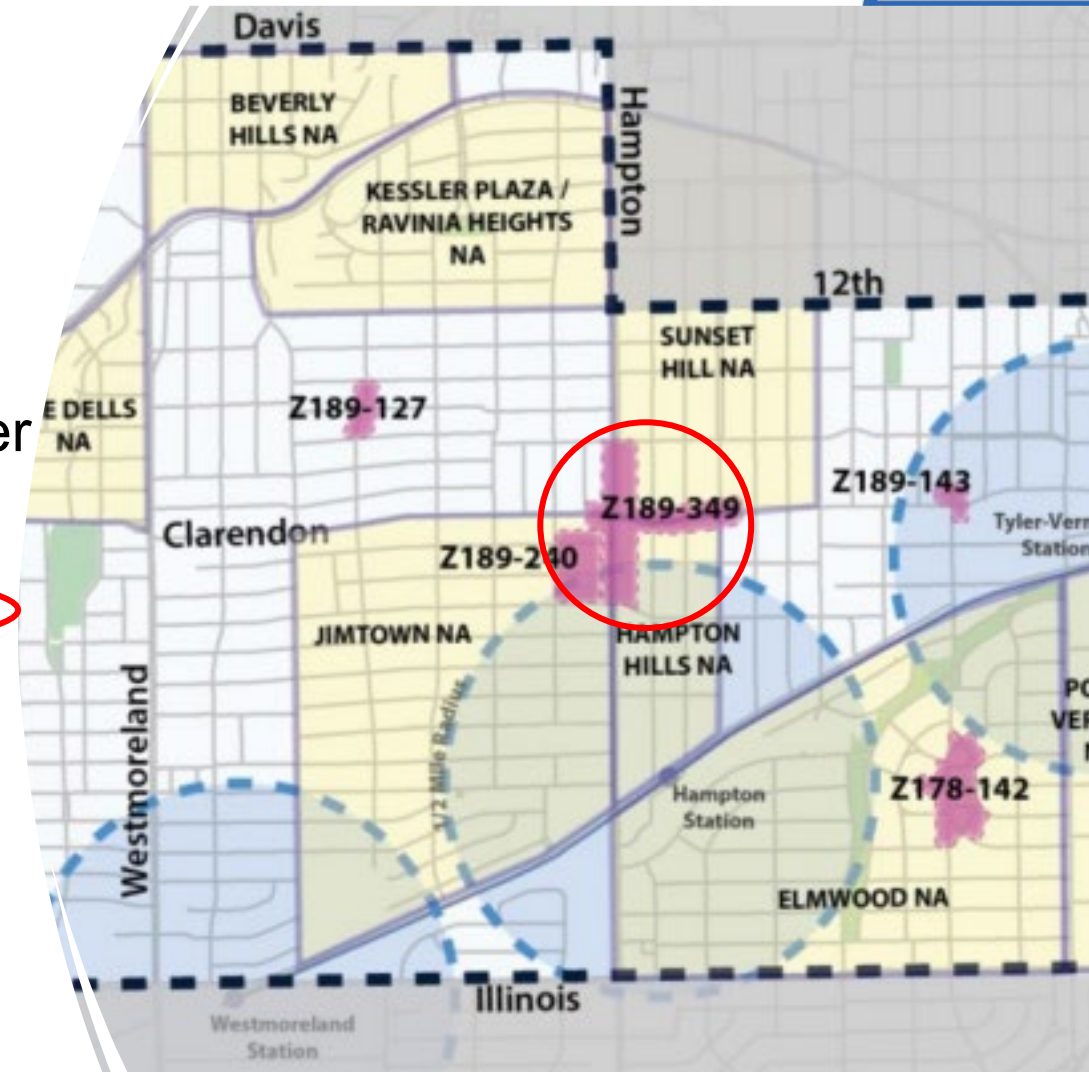

WOCAP Vision for the Commercial Areas

Visión WOCAP para las Áreas Comerciales



- Establish commercial districts that are ideal for small businesses that serve people in the neighborhood and the greater Oak Cliff area.
Establecer distritos comerciales que sean ideales para pequeñas empresas que atiendan a las personas del vecindario y del área metropolitana de Oak Cliff.
- Encourage businesses that are compatible with the surrounding neighborhoods.
Fomentar empresas que sean compatibles con los vecindarios aledaños
- Encourage adaptive reuse and renovation of existing structures.
Fomentar la reutilización adaptativa y la renovación de las estructuras existentes
- Implement traffic calming measures to make the district more walkable.
Implementar medidas para aminorar el tránsito para que el distrito sea más fácil de transitar a pie.

PLANNING GOALS



Protect existing single-family neighborhoods



Preserve natural areas and expand public parks and trails



Preserve historic buildings by encouraging renovation and reuse



Improve transportation access through better street design and suitable development around DART light rail stations



Encourage businesses that are compatible with surrounding neighborhoods



Retain current residents and attract new residents by encouraging new and affordable housing choices



Create walkable neighborhood centers that provide a variety of work, cultural, shopping and living opportunities





Z189-349 Hampton Clarendon Corridor

Z189-349 Corredor Hampton Clarendon



Photos / Fotos



Photos / Fotos



Photos / Fotos



Existing Zoning and Land Use

Zonificación y Uso del Suelo Existentes



Hampton-Clarendon area of request is comprised of approximately 35.25 acres and consists of 4 base zoning districts / El área de Hampton-Clarendon tiene aproximadamente 35.25 acres y 4 distritos de zonificación:

- **Community Retail District (CR)** includes community servicing retail, personal service, and office uses / **El Distrito de Comercio Comunitario (CR)** incluye servicios comerciales comunitarios, servicios personales y oficinas.
- **Commercial Service District (CS)** includes commercial and business serving uses that may involve outside storage, service, or display / **El Distrito de Servicios Comerciales (CS)** incluye usos comerciales y de negocios que pueden incluir almacenamiento, servicio o exhibición al aire libre.
- **Mixed Use District - 1 (MU-1)** includes moderate density retail, office, and/or multifamily residential uses in combination on single or contiguous building sites / **El Distrito de Usos Mixtos - 1 (MU-1)** incluye usos comerciales de densidad moderada, oficinas y/o usos residenciales multifamiliares en combinación edificios individuales o contiguos.
- **Regional Retail District (RR)** includes regional-serving retail, personal service, and office uses / **El Distrito de Comercio Regional (RR)** incluye servicios comerciales regionales, servicios personales y oficinas.

Current Zoning Map Hampton - Clarendon

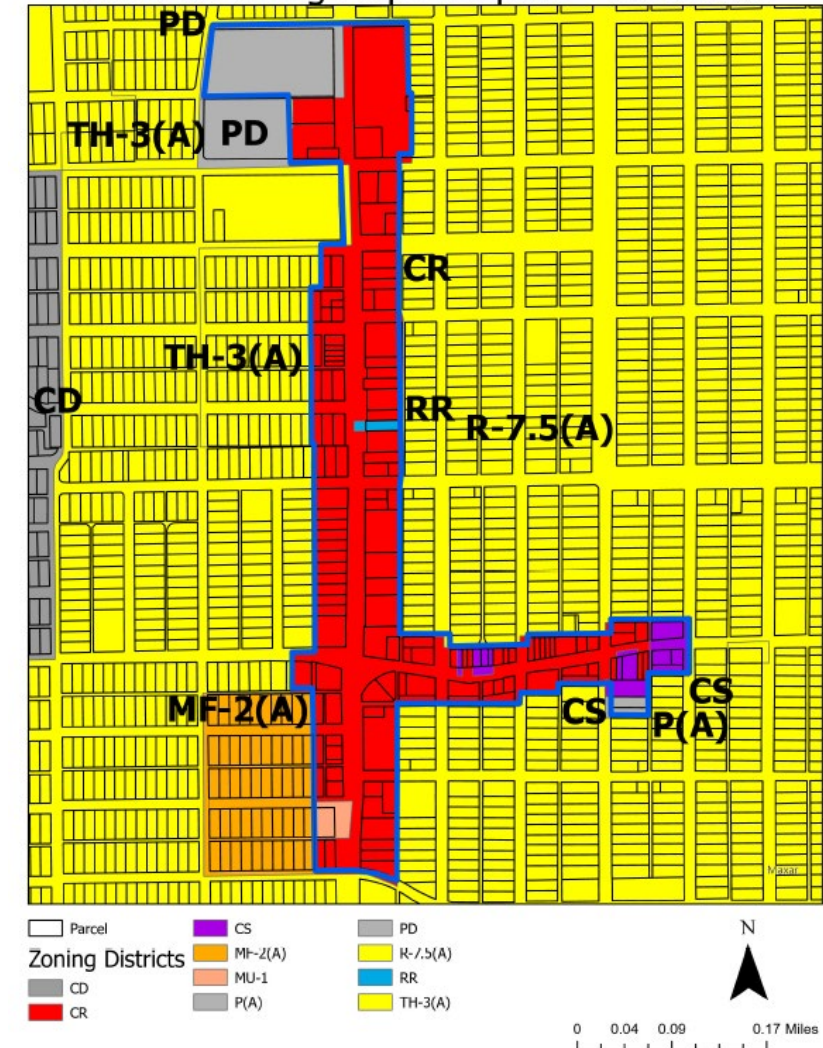

WOCAP Recommendations

Recomendaciones de WOCAP



The objective of this Authorized Hearing is to explore implementing the following recommendations of WOCAP / El objetivo de esta Audiencia Autorizada es explorar la implementación de las siguientes recomendaciones de WOCAP:

- Amend existing zoning (CR, MU-1, CS, and P(A)) to allow for mixed-use development along Hampton Road (between Wentworth and Brandon) and Clarendon (between Hampton and Marlborough) / Modificar la zonificación existente (CR, MU-1, CS y P(A)) para permitir el desarrollo de uso mixto a lo largo de Hampton Road (entre Wentworth y Brandon) y Clarendon (entre Hampton y Marlborough)
- Explore form-based zoning districts for walkable urban form, including activated facades and wide sidewalks / Explorar distritos de zonificación basados en un sistema de forma urbana peatonal e incluir fachadas activadas y aceras amplias
- Promote pedestrian-oriented design, minimizing vehicular-pedestrian conflict points, curb cuts, and parking locations. Explore prohibiting new drive-thru establishments / Promover el diseño orientado al peatón, minimizar los puntos de conflicto entre vehículos y peatones, cortes de acera y ubicaciones de estacionamiento. Explorar la prohibición de nuevos establecimientos con servicio por ventana
- Ensure proposed rezoning considers residential proximity slopes, setbacks, and landscaping to minimize impact on adjacent single-family properties / Asegurar que la rezonificación propuesta considere las pendientes de proximidad residencial, los espacios y el paisajismo para minimizar el impacto en las propiedades unifamiliares adyacentes
- Permit small multifamily developments (12 units or smaller) and townhomes within the designated areas / Permitir pequeños desarrollos multifamiliares (12 unidades o menos) y casas adosadas dentro de las áreas designadas.



Zoning Proposal/Propuesta de Zonificación



- Staff recommends **Form-Based Zoning (WMU-3)** for the district/**El personal recomienda Zonificación Basada en Formas (WMU-3)** para el distrito
- Form-Based Code (FBC) is a method of zoning where the codes and regulations focus on addressing the relationship between building facades and the public realm, form and mass of buildings relative to one another, and the scale and types of streets and blocks\ **El Código basado en la forma (FBC) es un método de zonificación en el que los códigos y regulaciones se centran en abordar la relación entre las fachadas de los edificios y el ámbito público, la forma y la masa de los edificios entre sí, y la escala y los tipos de calles y cuadras.**
- Unlike the Euclidean zoning that primarily regulates allowable use, FBC emphasizes the compatibility of the buildings with their surroundings, while letting the mix of actual activities in them be more eclectic\ **A diferencia de la zonificación euclidiana que regula principalmente el uso permitido, FBC enfatiza la compatibilidad de los edificios con su entorno, al tiempo que permite que la combinación de actividades reales en ellos sea más ecléctica.**

CHAPTER 51A
ARTICLE XII: FORM DISTRICTS
CITY OF DALLAS

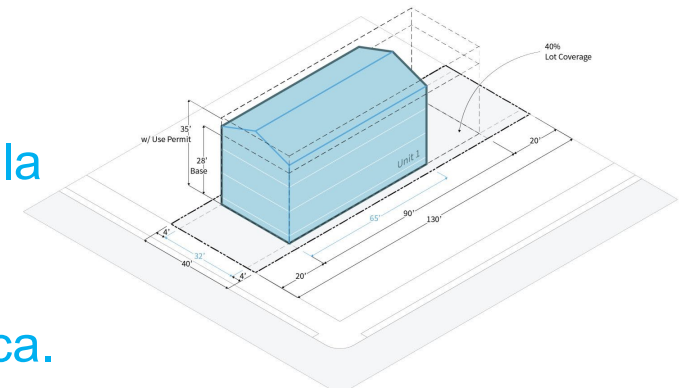
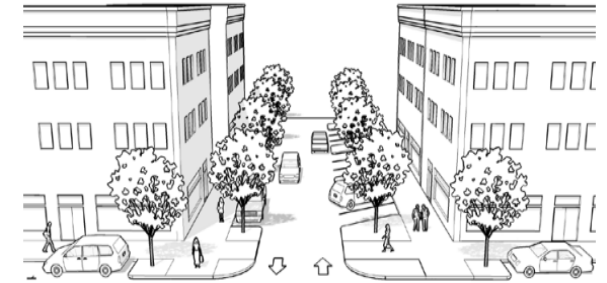

Form District Development Types

Tipos de desarrollo de distritos



	Mixed Use Shopfront	Single-Story Shopfront	General Commercial	Apartment	Townhouse Stacked	Townhouse	Manor House	Single-Family House	Civic Building	Open Space Lot
District	Mu	Ss	Gc	Apt	Ts	Th	Mh	Sf	Civ	O
Walkable Urban Mixed Use (WMU)										
Low (WMU-3, WMU-5)	■	■	■	■	■	■	■		■	■
Medium (WMU-8, WMU-12)	■		■	■	■	■			■	■
High (WMU-20, WMU-40)	■		■	■					■	■
Walkable Urban Residential (WR)										
Low (WR-3, WR-5)		■ *		■	■	■	■		■	■
Medium (WR-8, WR-12)				■	■	■			■	■
High (WR-20, WR-40)				■					■	■
Residential Transition (RTN)						■	■	■	■	■
Shopfront (-SH) Overlay over any WMU or WR district	■	■							■	■

See Section [51A-13.304](#), “Development Types.”



Development Type Examples\

Ejemplos de tipos de desarrollo



Manor House



Mixed-Use Shopfront



Single-Story Shopfront

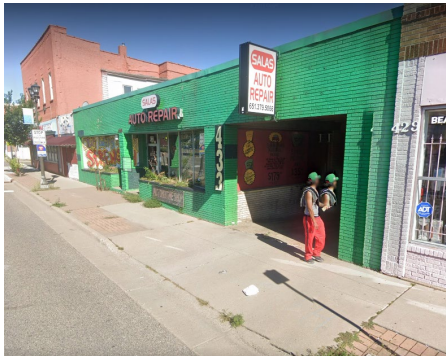

Townhouse Stacked





Zoning Proposals





Propuestas de Zonificación





Initial Proposal (September 24, 2024) / Propuesta Inicial (24 de septiembre de 2024)



-  Shopfront Overlay (Proposed)
-  WMU-3 (Proposed)
-  CR (Community Retail)
-  PD, Planned Development (Tom Thumb)
-  Parcel



Zoning Recommendations\ Recomendaciones de zonificación



- Aligns with WOCAP's goal of transforming the node into a neighborhood-scale mixed-use district that is pedestrian friendly\
Se alinea con el objetivo de WOCAP de transformar el nodo en un distrito de uso mixto a escala de vecindario que sea amigable para los peatones.
- No minimum acreage required for WMU zoning\
No se requiere superficie mínima para la zonificación de WMU
- WMU-3 allows a variety of housing types, nonresidential uses, and urban design standards to ensure the desired urban form\
WMU-3 permite una variedad de tipos de vivienda, usos no residenciales y estándares de diseño urbano para garantizar la forma urbana deseada.

https://codelibrary.amlegal.com/codes/dallas/latest/dallas_tx/0-0-0-93607



Development Standards Highlights\

Aspectos destacados de los estándares de desarrollo



1. Setbacks\ Contratiempos

- Front yard/primary street frontage: Min/Max 5/15 ft
Patio delantero/frente a la calle principal: mín./máx. 5/15 pies
- Side and rear yard: 5 feet (10ft abutting Residential District)\
Patio lateral y trasero: 5 pies (10 pies contiguos al distrito residencial)
- Lot Coverage: 100%-60% depending on development type
Cobertura del lote: 100% -60% dependiendo del tipo de desarrollo



2. Height\ Altura

- Max building height is 50 feet/3.5 stories\ La altura máxima del edificio es de 50 pies/3,5 pisos.
- Height bonuses may be provided for Mixed Income Housing Development Bonus (MIHDB) via PD Only\
Se pueden otorgar bonificaciones de altura para el Bono de Desarrollo de Vivienda de Ingresos Mixtos (MIHDB) únicamente a través de un Distrito de Desarrollo Planificado (PD)
- 3:1 Residential Proximity Slope (RPS) apply
Se aplica pendiente de proximidad residencial (RPS) de 3:1



Development Standards Highlights\

Aspectos destacados de los estándares de desarrollo



3. Landscaping\ Paisajismo

- As per Article X (Landscape and tree ordinance) of the Dallas development code
Según el Artículo X (Ordenanza de paisaje y árboles) del código de desarrollo de Dallas

4. Open Space\ Espacio abierto

- At least 8% of net land area of a site must be provided as open space
Al menos el 8% de la superficie neta de un sitio debe destinarse a espacios abiertos.

5. Screening\ Poner en pantalla

- All HVAC equipment, mechanical devices, and dumpsters must be screened from view from adjacent streets and properties.

Todos los equipos HVAC, dispositivos mecánicos y contenedores de basura deben estar protegidos de la vista desde calles y propiedades adyacentes.



Shopfront Overlay / Superposición de escaparate



- Shopfront (-SH) overlay is intended to create pedestrian shopping street frontages with development types that support active uses. / La superposición de fachada comercial (-SH) está destinada a crear frentes de calles comerciales peatonales con tipos de desarrollo que apoyen usos activos.
- Shopfront (-SH) Overlay may be applied over any WMU and is intended to accommodate a limited set of development types. / La superposición de fachada comercial (-SH) puede aplicarse sobre cualquier WMU y está destinada a acomodar un conjunto limitado de tipos de desarrollo.
- Where a -SH overlay designation is applied, the standards for a mixed use or single-story shopfront development type apply to at least the first 30 feet of the building measured inward from the street-facing facade. / Donde se aplica una designación de superposición -SH, los estándares para un tipo de desarrollo de fachada comercial de uso mixto o de una sola planta se aplican a al menos los primeros 30 pies del edificio medidos hacia el interior desde la fachada que da a la calle.
- The boundaries are not required to follow lot lines or match parcel boundaries. / Los límites no están obligados a seguir las líneas de los lotes ni a coincidir con los límites de las parcelas.



Public Realm Enhancements\ Mejoras en el ámbito público



- Changing zoning to WMU-3 form district could result in parking reduction\ Cambiar la zonificación al distrito de forma WMU-3 podría resultar en una reducción del estacionamiento
- Reconfiguring and redesigning the public ROW provides additional on-street parking that can be used to meet permitting requirements\ La reconfiguración y el rediseño del derecho de vía público proporciona estacionamiento adicional en la calle que se puede utilizar para cumplir con los requisitos de permisos.

Long-Term Goals

- Traffic calming\calmar el tráfico
- Sidewalk enhancements\Mejoras en las aceras
- Service parking in the back\Aparcamiento de servicio en la parte trasera.
- Potential art opportunities\ Posibles oportunidades artísticas



Non-Conforming Structures\ Estructuras no conformes



Per the code, if a structure becomes non-conforming with a zoning change: \ De acuerdo con el código, si una estructura se vuelve no conformante debido a un cambio de zonificación:

- Existing structures not required to conform retroactively unless **major renovations** are made to the buildings. / Las estructuras existentes no están obligadas a conformarse de manera retroactiva a menos que se realicen renovaciones importantes en los edificios.
- **Major renovation** means a building permit or series of building permits for the reconstruction, alteration or modification of building that increases the floor area by at least 35 %\ "Renovación importante" significa un permiso de construcción o una serie de permisos de construcción para la reconstrucción, alteración o modificación de un edificio que aumenta el área de piso en al menos un 35%.
- Total additions to existing non-conforming structures less than or equal to 35% of the original floor area existing as of [date of passage] must comply with the use and placement requirements and the height and elements requirements in Section 51A-13.304 for the development type.\ Las adiciones totales a las estructuras no conformes existentes, que sean menores o iguales al 35% del área de piso original existente a partir de [fecha de aprobación], deben cumplir con los requisitos de uso y ubicación, así como con los requisitos de altura y elementos en la Sección 51A-13.304 para el tipo de desarrollo.





RULES /REGLAS

1. Write your questions on the comments card and give it to staff. \ **Escriba sus preguntas en la tarjeta de comentarios y déjela al personal.**
2. Questions should be pertinent/relevant to the topic of discussion (Zoning). \ **Las preguntas deben ser pertinentes/relevantes al tema de discusión (Zonificación)**
3. No personal attacks on staff, community leader, a resident, and elected or appointed official / **No se permiten ataques personales contra el personal, líderes comunitarios, residentes y funcionarios electos o designados.**
4. No questions about the WOCAP planning process as that process is already completed and we are now on the plan implementation. \ **No se permiten preguntas sobre el proceso de planificación de WOCAP, ya que ese proceso ya está completo y ahora estamos en la implementación del plan.**



Next Steps\Próximos pasos



1. Another community meeting to review the proposal and feedback from property owners and the community and scenario testing (more meetings optional) \ Otra reunión comunitaria para revisar la propuesta, los comentarios de los propietarios y la comunidad, y las pruebas de escenarios (más reuniones opcionales).
2. City Plan Commission (CPC) public hearing (February - March)\ Audiencia pública de la Comisión de Planificación de la Ciudad (CPC) (Diciembre - Enero)
3. City Council Vote (TBD)\ Votación del Concejo Municipal (por determinar)

Jalyn Porchay, AICP
Candidate
Senior Planner
Planning & Development
Department
City of Dallas

Jalyn.porchay@dallas.gov
Tel. 214-671-5075

Follow project updates at: \Siga las actualizaciones del proyecto en:
<https://dallascityhall.com/departments/pnv/Pages/HamptonClarendonAH.aspx>

