

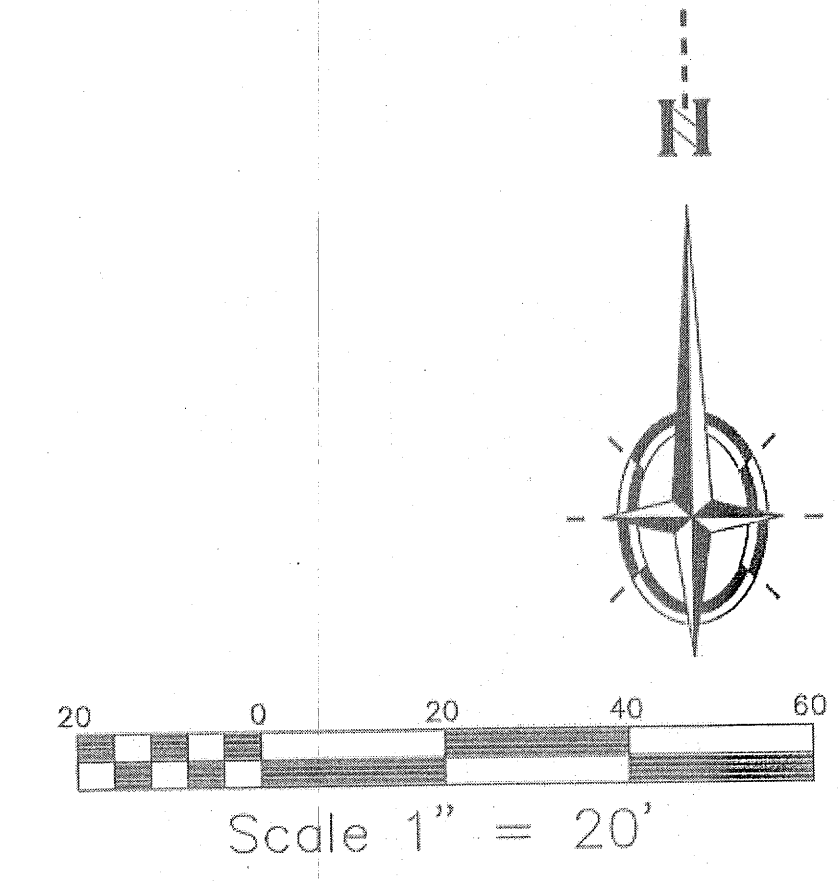

**SITE SUMMARY**  
 ZONING: CR-D1  
 REQUEST: Off premise alcohol sales in conjunction with a general merchandise or food store less than 3500 s.f.  
 EXISTING USE: General merchandise or food store less than 3500 s.f.  
 REQUIRED PARKING: 17  
 PROVIDED PARKING: 21

**SITE PLAN**

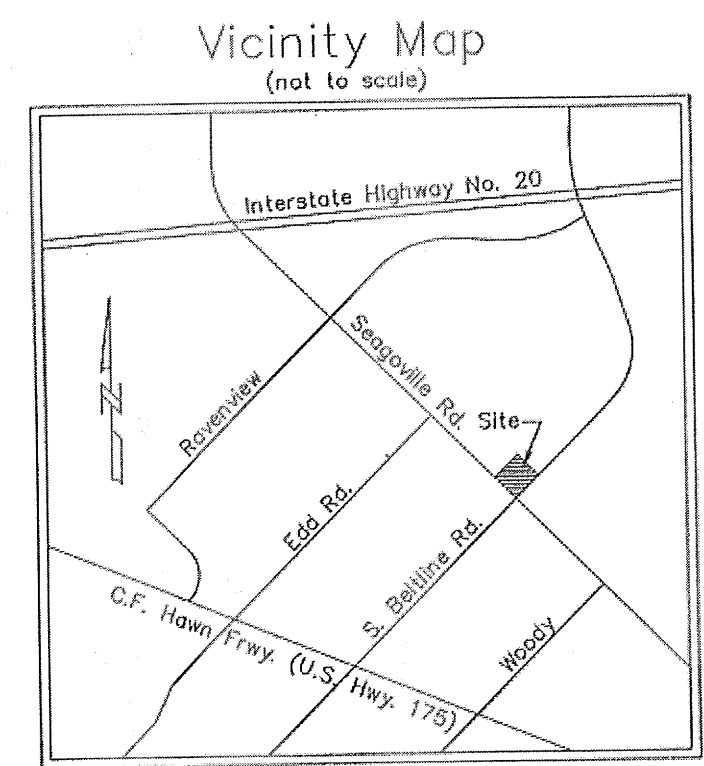

Property Zoned CR/D-1  
 Beer/Wine off-premise/Mixed in restaurants with certificate

Sheet 1 of 1

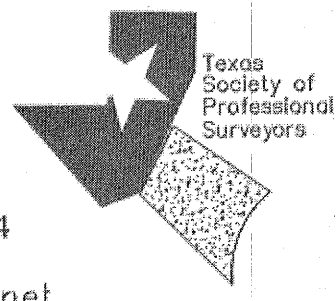
	<b>SURVEYING ASSOCIATES</b> 1018 SOUTH BECKLEY AVE. DALLAS, TEXAS 75203			DRAWN BY Lynn L.
	PHONE (214) 948-3324 FAX (214) 946-7540 Email: Brychlik@SWBell.net			11-205-L JOB NO.

Z190-221