

PHASE II

LOT 66A
BLOCK JJ/7135
7.258 ACRES
PD 508 LOT 5

BUILDING 3
NEW SCHOOL BUILDING
23 MIDDLE SCHOOL HOMEROOMS
12 HIGH SCHOOL HOMEROOMS
2 STORY
36'-0" MAX HEIGHT
70,000 SQ. FT.

HEIGHTS PREPARATORY SCHOOL
2850 CANADA DRIVE
BUILDING 1
EXISTING CLASSROOM BUILDING
5 MIDDLE SCHOOL HOMEROOMS
8,623 SQ. FT.

BUILDING 2
EXISTING BUILDING
2 MIDDLE SCHOOL HOMEROOMS
1,712 SQ. FT.

BUILDING SQ. FOOTAGE	
EXISTING	= 10,335
NEW	= 70,000
(44,000 FIRST FLOOR)	
TOTAL	= 80,335
LOT SQ FOOTAGE	= 316,158
FAR	= 80,335/316,158 = .25
LOT COVERAGE	= 54,335 SQ FT
LOT COVERAGE%	= 54,335/316,158 = 17%

PROXIMITY SLOPE DIAGRAM

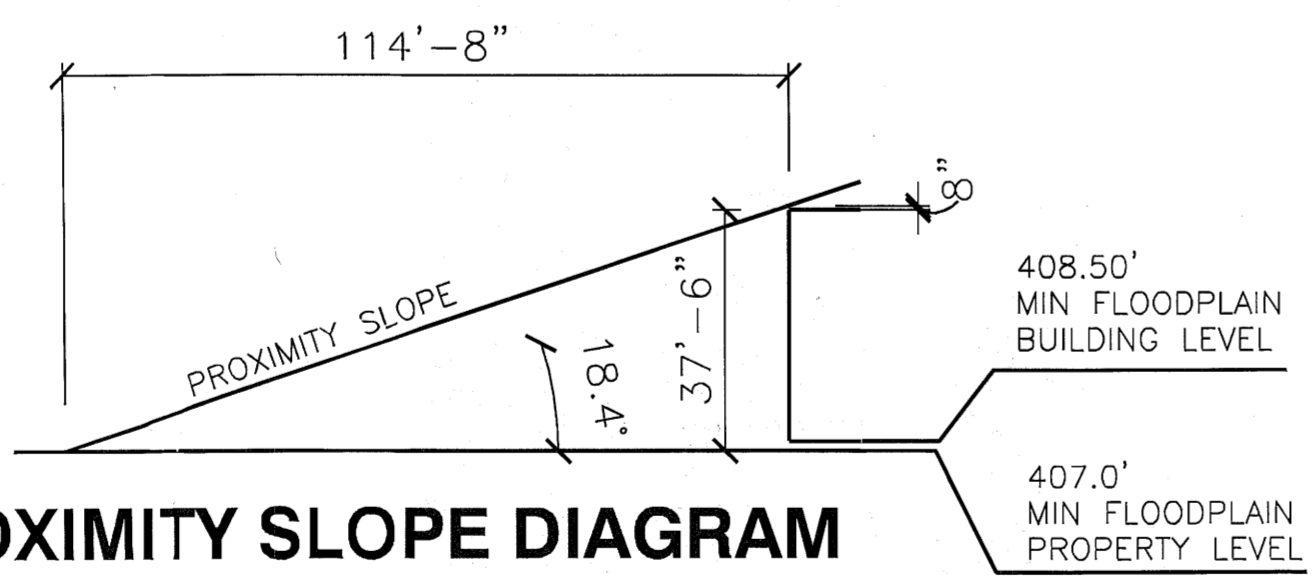

PARKING REQUIREMENTS

CLASSROOM TYPE	CLASSROOM NUMBER	PARKING REQUIREMENT	REQUIRED PARKING	PROVIDED PARKING
MIDDLE SCHOOL	30	REQUIRED PARKING AT 3.5:1	105	105
HIGH SCHOOL	12	REQUIRED PARKING AT 9.5:1	114	114
TOTAL			219	219
HANDICAP SPACES		REQUIRED PARKING AT 7 PER 201-300	7	8

VICINITY MAP

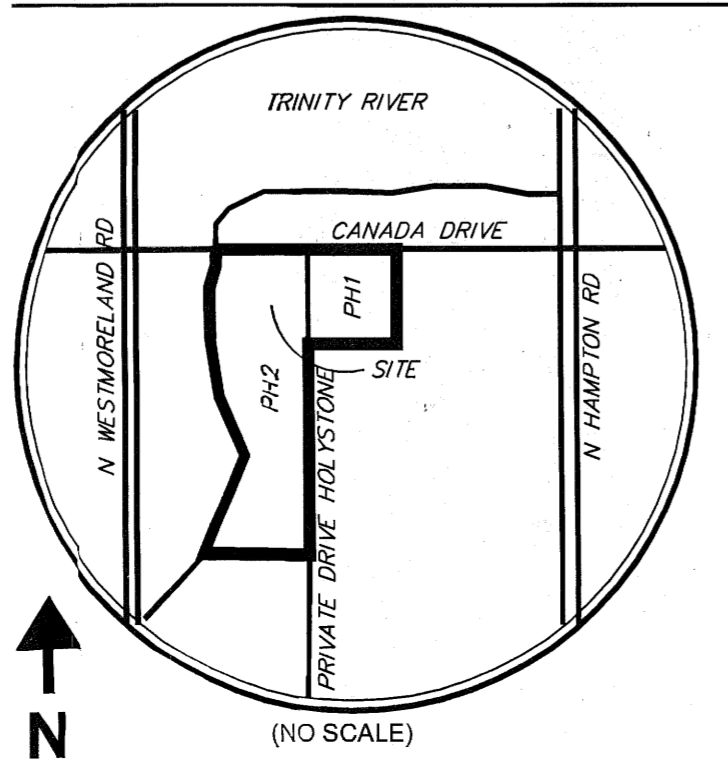

HEIGHTS PREPARATORY SCHOOL - (PUBLIC CHARTER SCHOOL) UPLIFT EDUCATION

2850 CANADA DRIVE DALLAS, TX 75212

01/03/12 revised 04/13/12

UPLIFT EDUCATION **HKS** **DEVELOPMENT PLAN**

APPLICANT: UPLIFT EDUCATION, 608 ROYAL LANE, IRVING, TX 75039

ARCHITECT: HKS INC, 1913 MCKINNEY AVENUE, DALLAS, TX 75201

SCALE 1" = 30'-0"

**Subject to compliance with the Traffic Management Plan dated April 09, 2012, and attached to this plan and city memos dated 11/3/12 as part of minor amendment application M112-013

PLANNED DEVELOPMENT DISTRICT NO 508 - TRACT 5 DEVELOPMENT PLAN

APPROVED BY CITY PLAN COMMISSION IN ACCORDANCE WITH THE PROVISIONS OF SECTION 51A-4.702 OF THE DALLAS DEVELOPMENT CODE.

DATE: 11/3/12

PLANNED DEVELOPMENT DISTRICT NO. 508 125

FILE NO. 2918-168