

# West End Historic District

Department of Urban Planning  
City of Dallas

# Table of Contents

- I. Purpose of Study
- II. History

---

- III. Ordinance Preparation
  - The District Boundaries
  - Permitted Uses
  - Preservation Criteria
- IV. Effects of Designation
  - Obtaining Building Permits
  - Demolition of District Structure
- V. Planning for Public Improvements
- VI. Economic Advantages
- VII. Source Materials

# West End Historic District

## Downtown Renewal Through Preservation

### PURPOSE OF STUDY

Dallas' growth, from its humble log cabin beginnings to its present status as a worldwide distribution and marketing center and modern county seat, can be viewed within the confines of the Westend Historic District. This location, formerly the major hub of town, constitutes one of the few intact, readily definable districts within the City today. The striking uniformity in height, color and materials; the intimate physical arrangement of narrow, often brick paved streets; create an ambience and character that can never be duplicated.

Concerned with the gradual decline and decay of the area, the Dallas City Council unanimously approved plans on October 6, 1975, creating the Westend Historic District. A program, combining public actions to improve open spaces and streets and private initiative aimed at upgrading and recycling existing facilities as well as encouraging compatible new construction, has been proposed. Hopefully the resultant product will be a multi-use activity node bordering and strengthening the downtown area. Office space as well as smaller specialty shops and boutiques, residential units of limited scale, will combine with existing uses to create a diverse, stimulating environment that will appeal to tourist, conventioner and native Dallasite in equal proportions.

This report has been prepared for the purpose of acquainting owners, developers and others with the basic goals and strategies to be employed by the City of Dallas in the revitalization of the area. Questions and requests for additional information should be directed to the Dallas Department of Urban Planning, 5BN, 1500 Marilla Street, Dallas, TX 75201, (214) 670-4120.

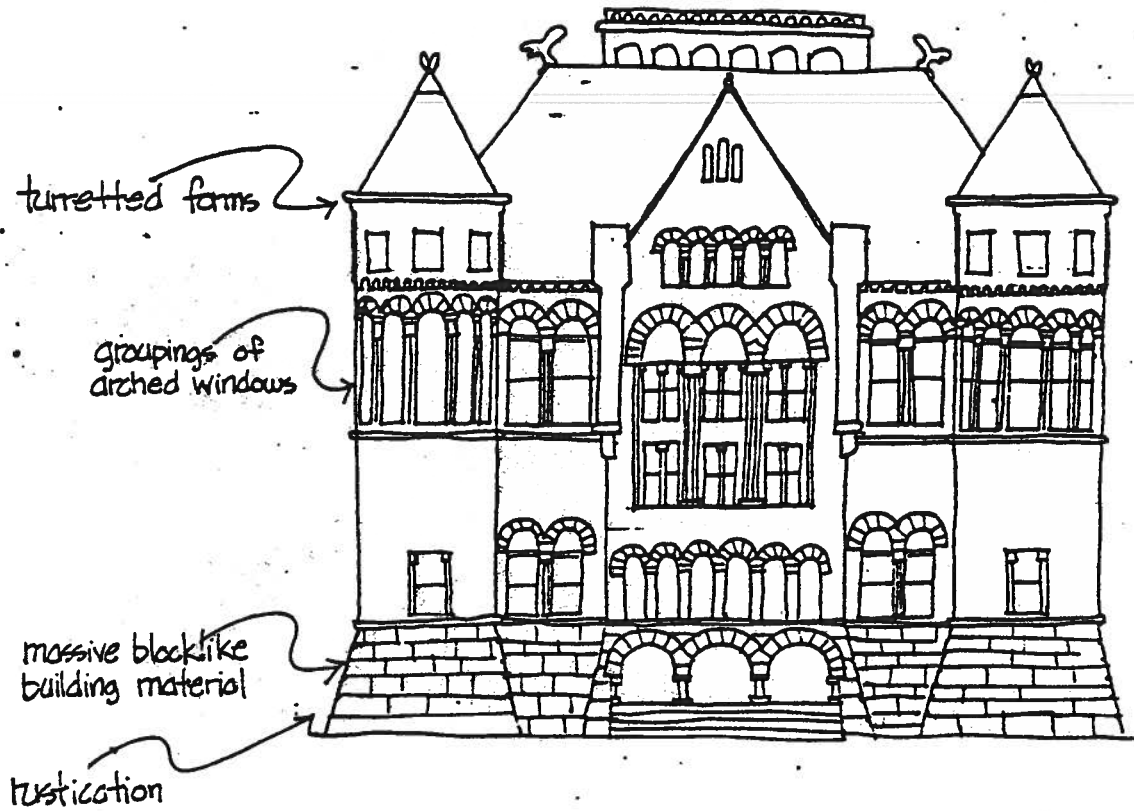

## HISTORY

Common with the settlement of many towns, the river played an important role in the development of Dallas. It was on the banks of the Trinity that the Caddo Indians, first known inhabitants of the land, hunted and fished. When the trader John Neely Bryan arrived, his interest was in the establishment of a permanent trade station. Bryan's plat, submitted in 1846, includes much of the present day historic district.

The town remained a relatively small frontier outpost until 1872 and the coming of the railroads. With the advent of rails the city quickly grew in size. The commercial and industrial center supplying the region with agricultural equipment centered in the rail yard area. Testimony to their presence is still evidenced in the faded letters on the brick walls--Allis Chalmers, John Deere, Parlin & Orendorff, Texas Implement.

Sanger Brothers, long acknowledged as the area's leading dry goods retailer, opened its doors on Main and Lamar just days after the first train's arrival. The East Texas oil boom further contributed to the area's prosperity and indirectly influenced the maturing of a significant mercantile and garment center. The Westend area developed to meet the demand.

Warehouses constructed were strongly influenced by the current architectural vogue, the Chicago School of Architecture. Characteristic of the style were wide, elongated multipaned windows, well defined cornice lines and detailed, elaborate decorative embellishment. The use of brick as a primary material and the uniformly consistent height furthers the district's visual cohesiveness.

The challenge then, is to couple the area's unique features with a concentrated program of revitalization and face-lifting. Unplanned and uncoordinated redevelopment will alter if not eradicate the fragile image. How then to proceed?

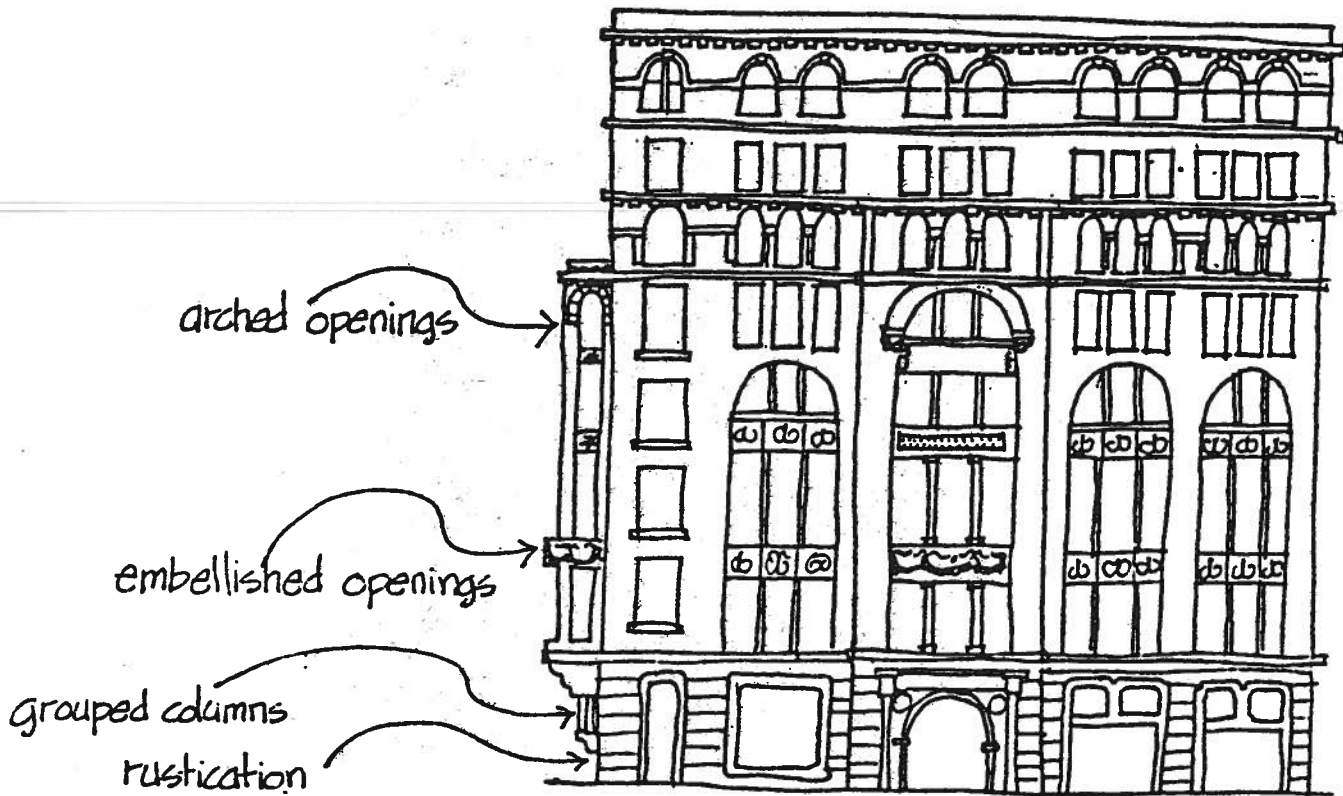

## ORDINANCE PREPARATION

Designating the area as a City of Dallas historic landmark district enables protection and encouragement of a specialized nature. The preservation legislation is addressed to three aspects: the boundary, permitted uses, and preservation (design) criteria.

### The District Boundaries

The boundary (see map)--bounded roughly by Commerce Street, Lamar, McKinney (Woodall Rodgers), the Railroad Yard and Dealey Plaza. The district comprises roughly 55 acres lying just west of the central business area. Access to the area is provided by public transit (buses on Commerce, Main, Elm, Houston, Market and Lamar). Automobile access is readily available as the area is well served by freeways bordering (Stemmons to the west, R. L. Thornton, south and Central Expressway (I-75) at Woodall Rodgers-McKinney). When completed, Woodall Rodgers Freeway (above grade by the historic district) will provide access at Field Street. Union Terminal, site of the La Reunion Development Project featuring the Hyatt-Regency Hotel and Observation Tower, is just south of the designated area on Houston and Jackson. The Terminal, renamed the Transportation Center, will provide taxi service as well as access to Love Field and Dallas/Fort Worth Airports (Surtran Bus), limousine service and Amtrak rail service.

### Permitted Uses

All uses permitted prior to historic designation will be retained. The former zoning CA-1 has been changed to CA-IH. This is a very flexible use classification that allows for great mix and diversity. Warehouse uses

can continue and will be encouraged as this activity is basic to the area's history and setting. As market conditions permit, it will be left to the discretion of the individual owners or leasees to determine appropriate uses. The hoped for product will be a true urban mix that will be both stimulating and imaginative as the existing uses mix with other activities including commercial, office and residential. Small theaters, restaurants, boutiques and professional offices will all lend to the establishment of an all purpose day/night activity center.

---

### Preservation Criteria

Designated landmark areas are generally distinguished by an overwhelming physical, cultural and/or historic identity. The Westend Area's strong design character and intact condition strongly satisfies the landmark requirements. Preservation criteria enumerated in the Ordinance contain the essential basics necessary to conserve the present warehouse/commercial image while encouraging renovation and new construction. During the preparation of the ordinance, a special task force of the Landmark Preservation Committee was created. Serving on the group were: area property owners, developers, investors, representatives of professional organizations and others working closely with the staff of the Department of Urban Planning. Criteria proposed had to be justifiable on economic as well as aesthetic grounds.

### Height

Surveys of the area indicate many buildings to be 2-3 story structures ranging from 25' - 40' in height. The largest building constructed in the



# West End Historic District



area is eight stories. Preservation of the low-rise, boxy profile of the Westend area is the most essential element necessary for maintenance of district unity. Therefore, new construction, additions and alterations cannot exceed 100 feet in height.

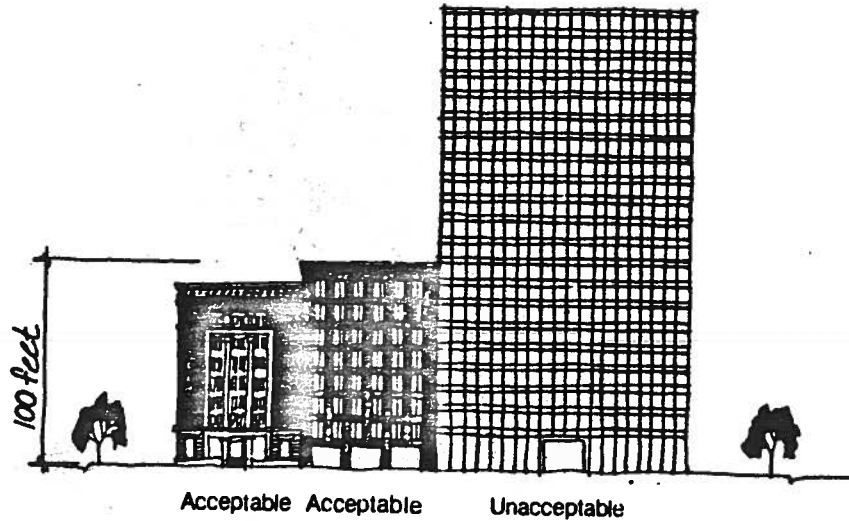

Building Height

### Use of Building Materials

Predominate Facade Material - Perhaps the most apparent shared trait found throughout the district is the overwhelming use of brick as the primary building material. Brick--its texture, grain, joint pattern and color ranges--creates a particular quality that cannot be duplicated in other materials. All proposals for new constructions, additions, and alterations will be reviewed and approved, based on the use of brick as the basic facade material (exceptions are possible for non-conforming structures, although brick will be encouraged).

Trim Element Materials - Trim can be considered as detailing to a building's facade plan. Areas of trim, including columns, roof lines, surfaces encircling windows as well as additional elements that may be accentuated

in a building's design, may use a variety of materials to elaborate detailing. Trim material may be any of the following: brick, cast stone, stone, cast iron or concrete.

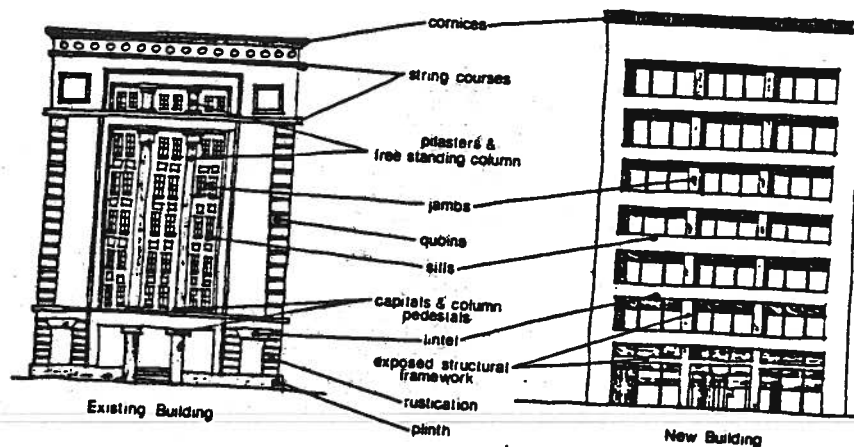

Trim Elements  
Color & Materials

Window Materials - Only two-way glass may be used in windows. Reflective and spandrel glass (exterior glass used to span area between floors) are considered inappropriate for the locale.

### Color

The historic zone is an area of striking color continuity. This can be especially appreciated during the late afternoon hours when the setting sun creates hues and tones reminiscent of a New Mexico mesa scene. Earth tones, reds and bricks are especially apparent.

Serving as an accurate tool to define color, the Munsell System of Color Notation (see, Munsell Book of Color: Neighboring Hues Collection, 1973\*) illustrates and describes the full range of color gradients. The system has been in popular use for many years and is a standard reference for

\* Copy on file, Dallas Department of Urban Planning

major paint manufactures, scientists and others concerned with accurate color documentation requirements.

Munsell Tables are based on color, value, and chroma (intensity). A sampling of colors, based on the existing range in the district has been compiled and described for predominant and trim colors. Acceptable shades for the predominate area (typically brick) will range from yellows to reds. Trim need not match the predominant colors and may employ shades of whites and greys.

MUNSELL® BOOK OF COLOR  
Neighboring Hues Edition - Matte Finish Collection

SR

HUE SYMBOL

5 R

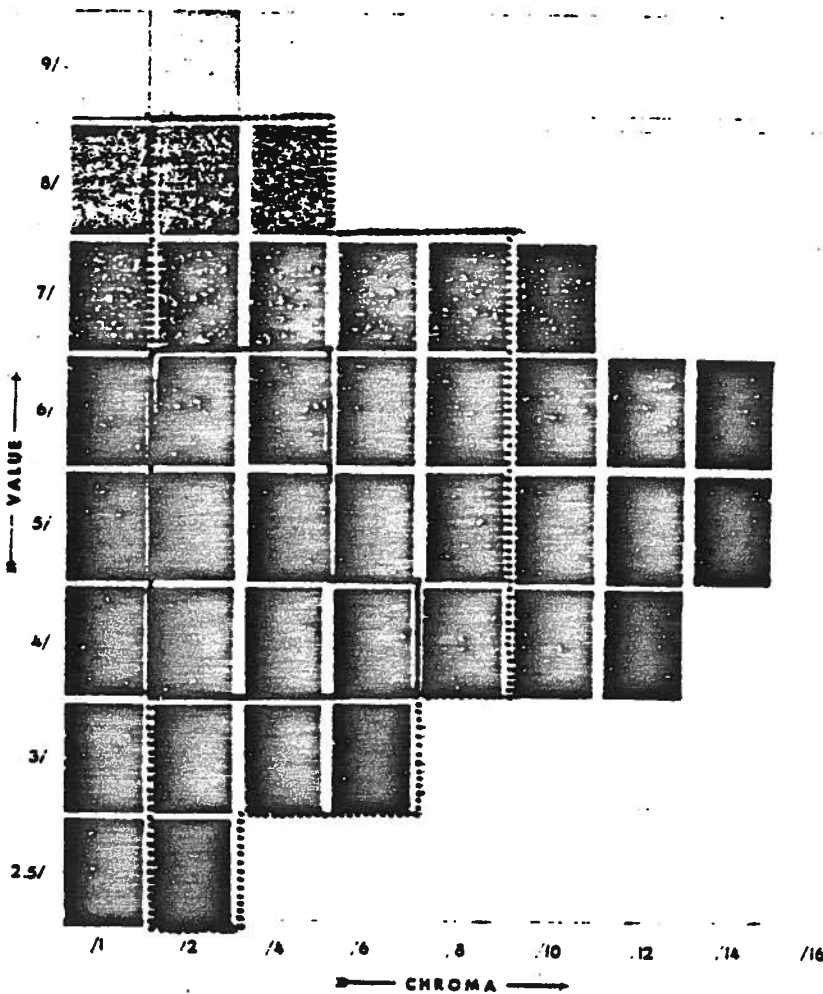

Doors, awnings, signs, window frames and mullions, ornamental moulding and friezes are defined as accent areas and may employ any color application with the exception of fluorescent shades.

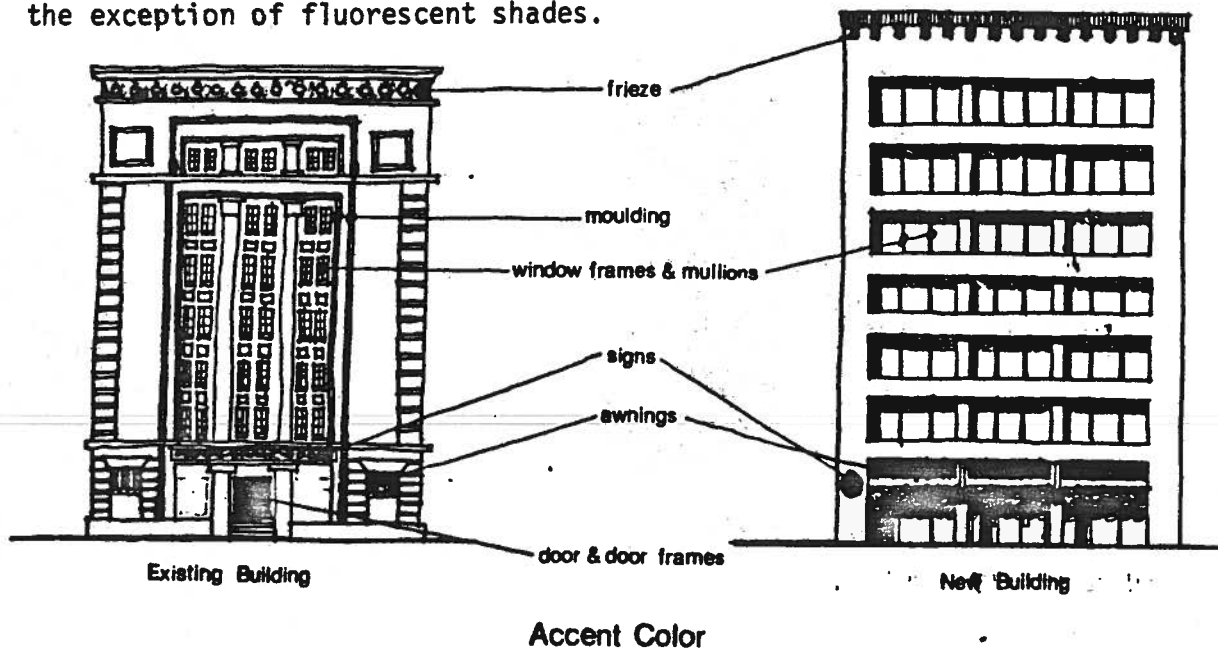

### Facade Treatment

The internal harmony of the locale can be attributed to the unifying treatment given by the developers of the area. Windows of common size, style and placement are much in evidence. An orderly arrangement of openings within each structure is standard. Advances in technology and building techniques allow construction methods that could not be envisaged by these turn-of-the century builders. Encouragement of unique design solutions within an overall framework is both necessary as well as desirable. It is with this intent that consideration is directed to facade appearances, particularly the relationship between solids and voids.

The solid to window ratio requirement, developed as a provision, is designed to discourage both glass as well as monolithic appearing straight brick facades. The amount of area allocated for openings cannot be greater than 50% nor less than 30% of the facade wall.

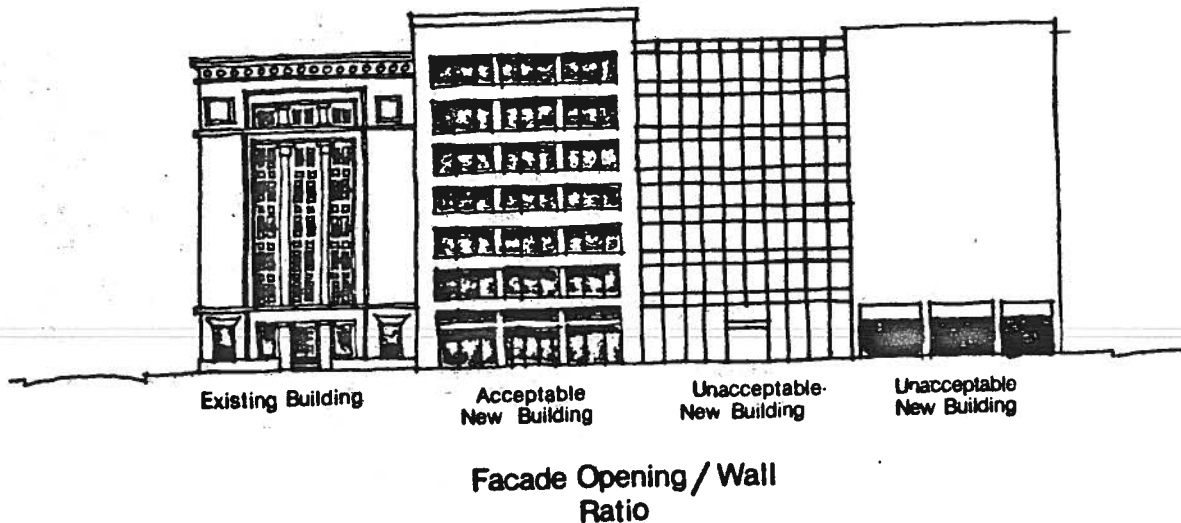

Distribution openings must be in a regular internal pattern providing for vertical and horizontal repetition. This is a very characteristic element of the Chicago School of Architecture and is one of the more subtle but nonetheless critical design arrangements that convey the district's visual cohesiveness.

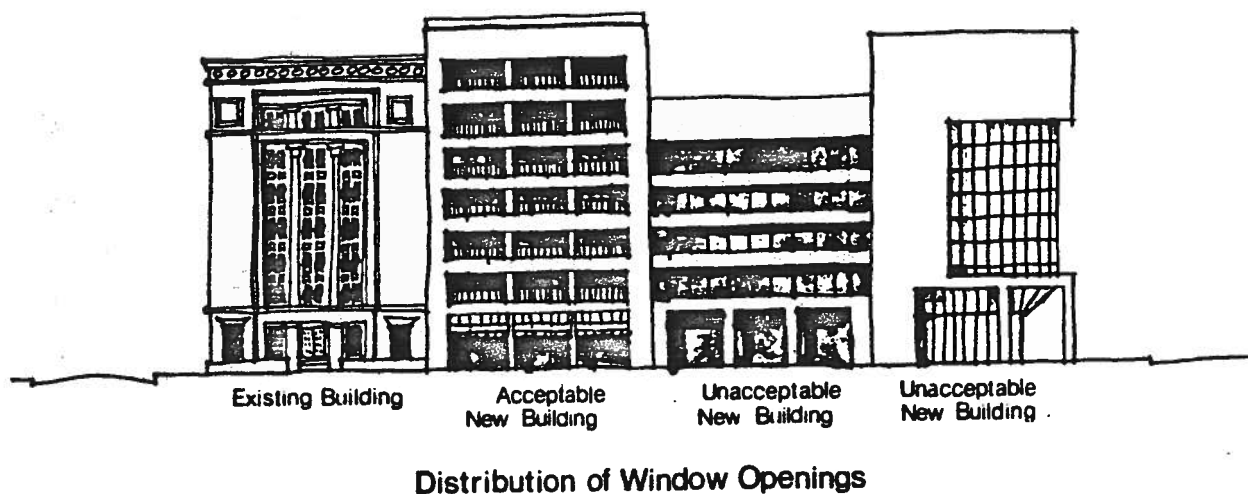

Window Setback - Windows must be set back a minimum of six inches. This will provide facade differentiation and will emphasize openings and wall.

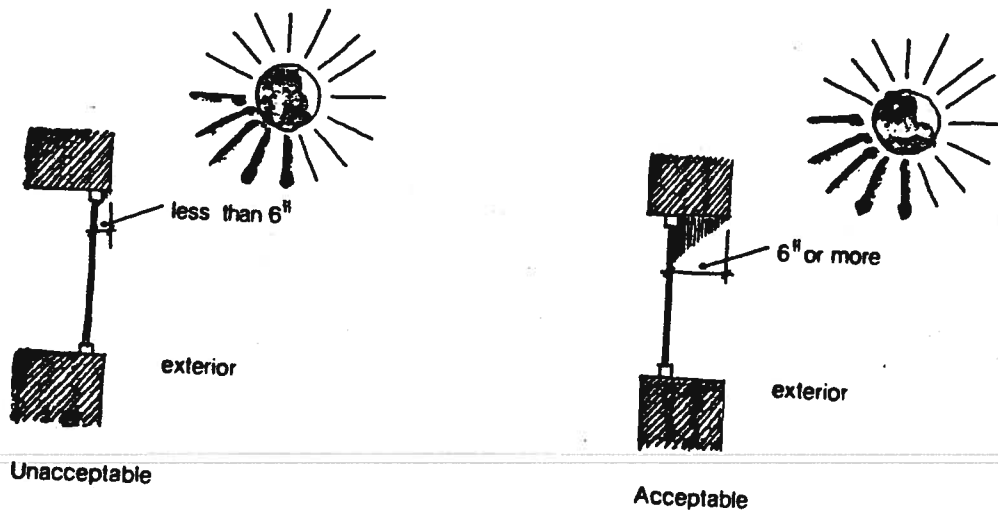

### Window Setback

Note: Party walls or interim facades not exposed to public view on public right-of-way are not required to satisfy criteria relating to facade treatment (coverage, distribution, setback).

### Site Criteria

Signs - For the present, signage requirements are minimized. When additional activities are generated and a general theme defined, a special sign ordinance may be prepared if owners and developers are agreeable. For now, no sign may extend above the cornice line or the uppermost portion of the facade wall.

Building Service Facilities - Areas including loading docks, trash and refuse

collection, equipment storage and other services related to the support of an individual building facility cannot be established fronting a designated landscaped open space or mall. In the planning for open spaces, owners will be regularly consulted and efforts will be made to accommodate wherever feasible. Present service facilities may continue uninterrupted use.

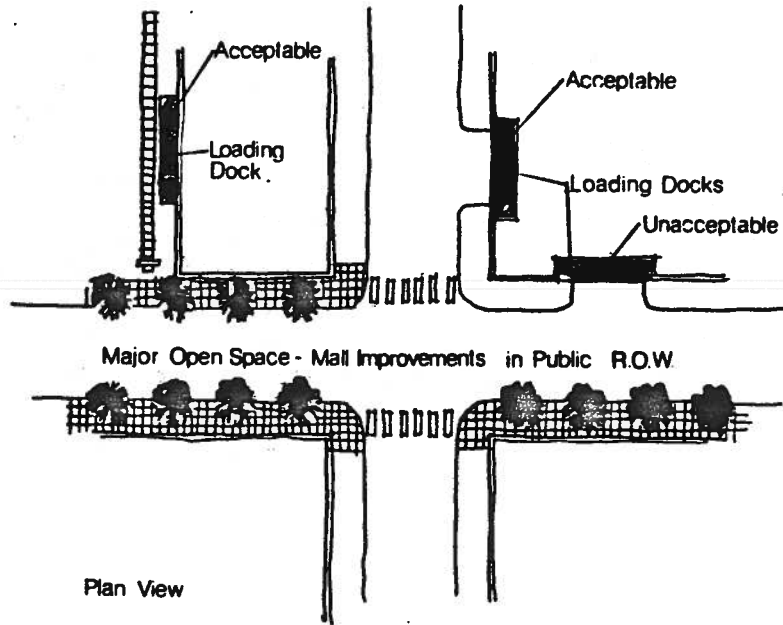

Building Service Facilities

Parking Lots - Parking areas adjacent to public rights of way must provide walls of brick or brick-like texture (cast in place concrete) or wood not less than 18" in height to screen and define parking facilities. Walls may be complimented by plantings and shrubs at the discretion of the developer.

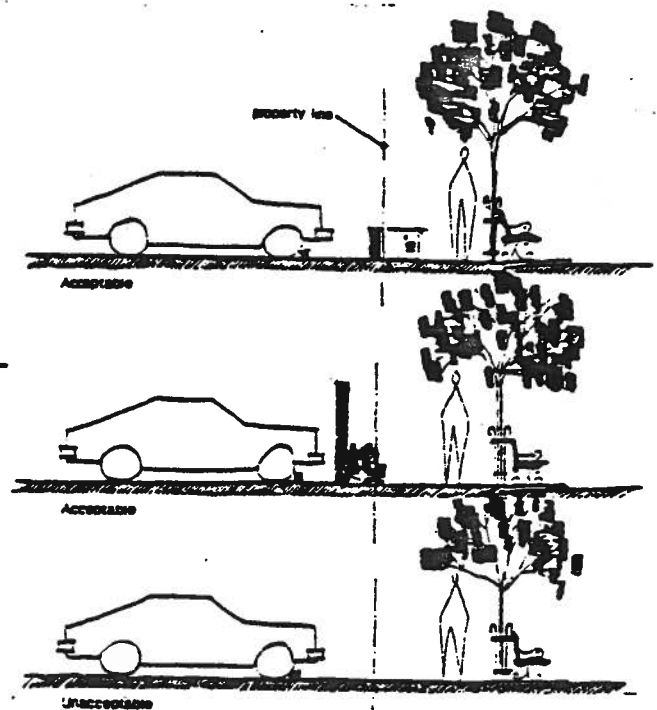

Parking Lot Screening



## EFFECTS OF DESIGNATION

The historic landmark zoning for the Westend area was developed to stimulate orderly growth and development. The specific design criteria enumerated in the previous section define in general terms new and remodeled designs that would be compatible within the existing framework.

The designation status affects the exteriors of buildings only. Interior remodeling and alteration is left solely to the discretion of the individual, providing satisfactory compliance with building and health code requirements.

Owners and others contemplating alterations are advised that building permits are required prior to proceeding with the work.

### Obtaining Building Permits

Permits are required for most alterations, modifications and reconstruction to structures located within the City of Dallas. Permit review insures compliance with the City's building codes. The review and inspection insures that structures meet minimum safety and health requirements.

Normally building plans and accompanying permit applications are reviewed by several city agencies. Applications are routinely inspected by the Department of Housing and Urban Rehabilitation, the Fire Department and the Department of Public Works. Within designated landmark areas, the Historic Landmark Preservation Committee and Plan Commission must also review applications for work affecting the exterior.

All proposed work including new additions, alterations, new construction,

exterior painting and other modifications that affect the exterior appearance as outlined in the preservation criteria will be reviewed by the Landmark Committee. Issuance of a Certificate of Appropriateness is necessary prior to commencement of work. In the event of a denial of a Certificate of Appropriateness, the applicant may either modify his plans and resubmit or appeal to the City Council.

Generally applications are processed within several weeks, although a complex case involving major remodeling or new construction might take somewhat longer. Applicants are encouraged to consult with the Landmark Committee and staff, prior to submittal of an application.

In summary, the process for receiving a Certificate of Appropriateness and Building Permit is as follows:

1. An applicant considering exterior changes is advised to call the Department of Urban Planning and consult with the staff to arrange a preview of proposed work with the Landmark Committee and staff.
2. Following this session, the applicant should then submit the necessary forms and applications including two copies of all plans, elevations, perspectives, specifications and other documents to the Building Inspection Division, 1500 West Mockingbird Lane along with a permit application.
3. This material will be forwarded to the Department of Urban Planning within 5 days from date of application. An applicant may meet with representatives of the Landmark Committee and

Department of Urban Planning prior to submittal of the application.

4. The Landmark Committee will review all proposed work and determine on the basis of the preservation criteria specified in the Westend Ordinance whether the proposed work is appropriate. If the alteration, modification or new construction will not adversely affect the historic, architectural, archaeological or cultural features of the district, then the Committee will recommend to the City Plan Commission that a Certificate of Appropriateness be issued.
5. The Landmark Committee and the City Plan Commission have the authority to approve or deny issuance of a Certificate of Appropriateness.
- 6a. If a Certificate of Appropriateness has been issued, notification will be made within ten (10) days to the Building Inspection Division of the Department of Housing & Urban Rehabilitation.
- 6b. If a Certificate of Appropriateness has been denied the applicant may file an appeal with the Plan Commission within ten (10) days of notification. The appeal will be placed on the agenda for review by the City Council.
7. When a Certificate of Appropriateness has been approved, Building Inspection Division will immediately notify the applicant that a building permit has been issued and work may commence.

The entire process from date of application to notification of action on the building request must be completed within forty-five (45) days. If the

applicant has not received notification within this period, the building permit is automatically issued. Normally the process is completed within a week to ten days from the date of the original application.

## Dallas Historic Landmark Program - permit review

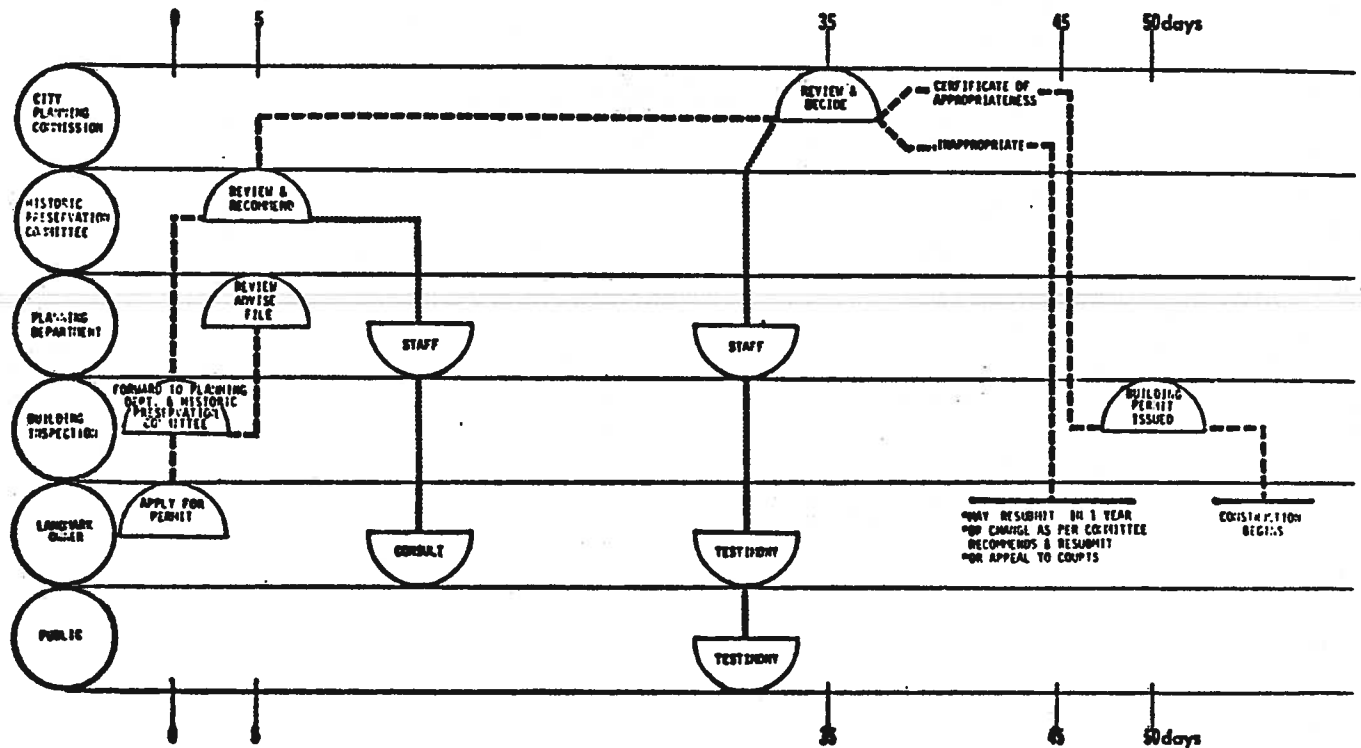

### Demolition of a District Structure

If an application has been received by the Building Inspection Division for a demolition permit, the Historic Landmark Committee will be promptly advised. The City Planning Commission will hold a public hearing within thirty days from the date of application. Basis for a decision will be the report of the Landmark Committee as well as a consideration of the state of repair of the building, the cost of restoration or repair, the intrinsic value of the landmark, and the character of the neighborhood.

If the Commission determines that the building may be demolished, the Building Inspection Division is notified and a demolition permit is issued. In the event the Planning Commission determines that the building should not be destroyed, the application may be suspended for a period not to exceed ninety (90) days from the date of the application. During this period, the City Planning Commission may request an extension by the City Council. If the City Council does decide through a public hearing that postponement is necessary, this may be done for an additional period not to exceed one hundred twenty (120) days. If action is not taken within two hundred forty (240) days from the original date of application, the demolition permit is considered issued and valid.

## Dallas Historic Landmark Program - review of demolition

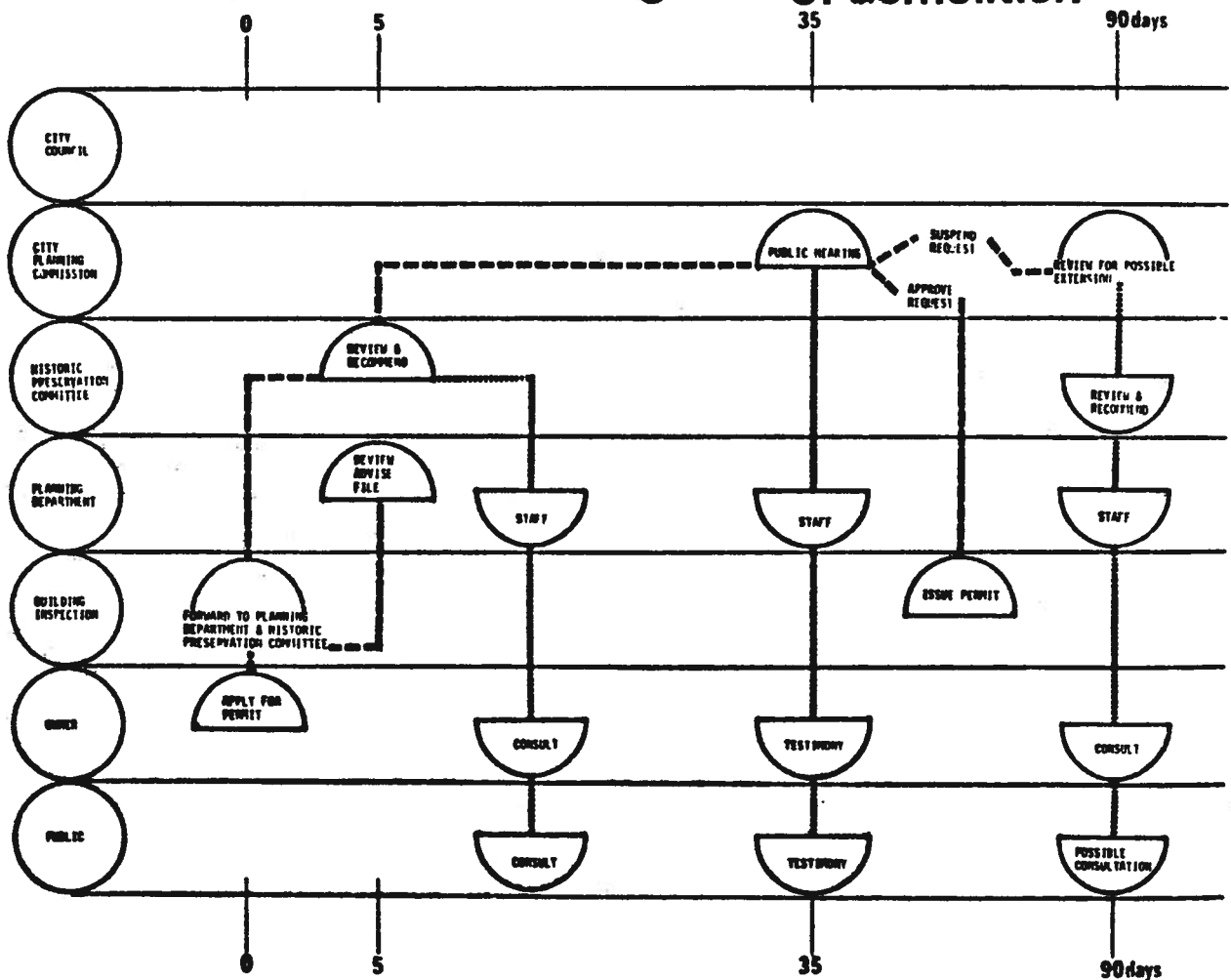

## PLANNING FOR PUBLIC IMPROVEMENTS

A proposal for the enrichment and revitalization of the district supplements the Westend landmark designation. Through a joint spirit of cooperation between the public and private sectors, improvements in the area can be effected. Financing for public projects will be achieved principally through bond election programs.

The public improvement program will consist of several stages and elements. A plan will be developed incorporating the existing situation with a workable timetable and priority listing of projects.

Existing problems--the street circulation pattern, inadequate lighting and parking facilities and lack of public amenities will receive immediate consideration.

The following list enumerates items to be considered in this development plan:

1. Streets - closing, widening, resurfacing, etc.
2. Public open spaces - malls, parks, plazas and other public spaces.
3. Street hardware - provision for distinctive street hardware that would be compatible with the area.
4. Lighting - distinctive lighting for streets and other public places to define and identify the area.
5. Transportation facilities - parking facilities, special bus routes from the district to other major points in the downtown area such as major hotels, major department stores, the Convention Center, and the Stemmons facilities. Also there will be

provisions for transit stop(s) when a mass transit system is built.

First stage funding will be determined based on overall impact of the improvements as well as a consideration of nodes and facilities prepared for immediate reuse and development.

Planning for the redesign of the area is preceding at the present time. Staff of the Department of Urban Planning have surveyed the area to determine a basis for a conceptual plan. Over one million dollars, approved in the bond election held November, 1975, has been allocated for first phase improvements. Following completion of initial field work, owners will be contacted for review and comment. No public actions will be taken without consultation of affected property owners.

# Public Improvements

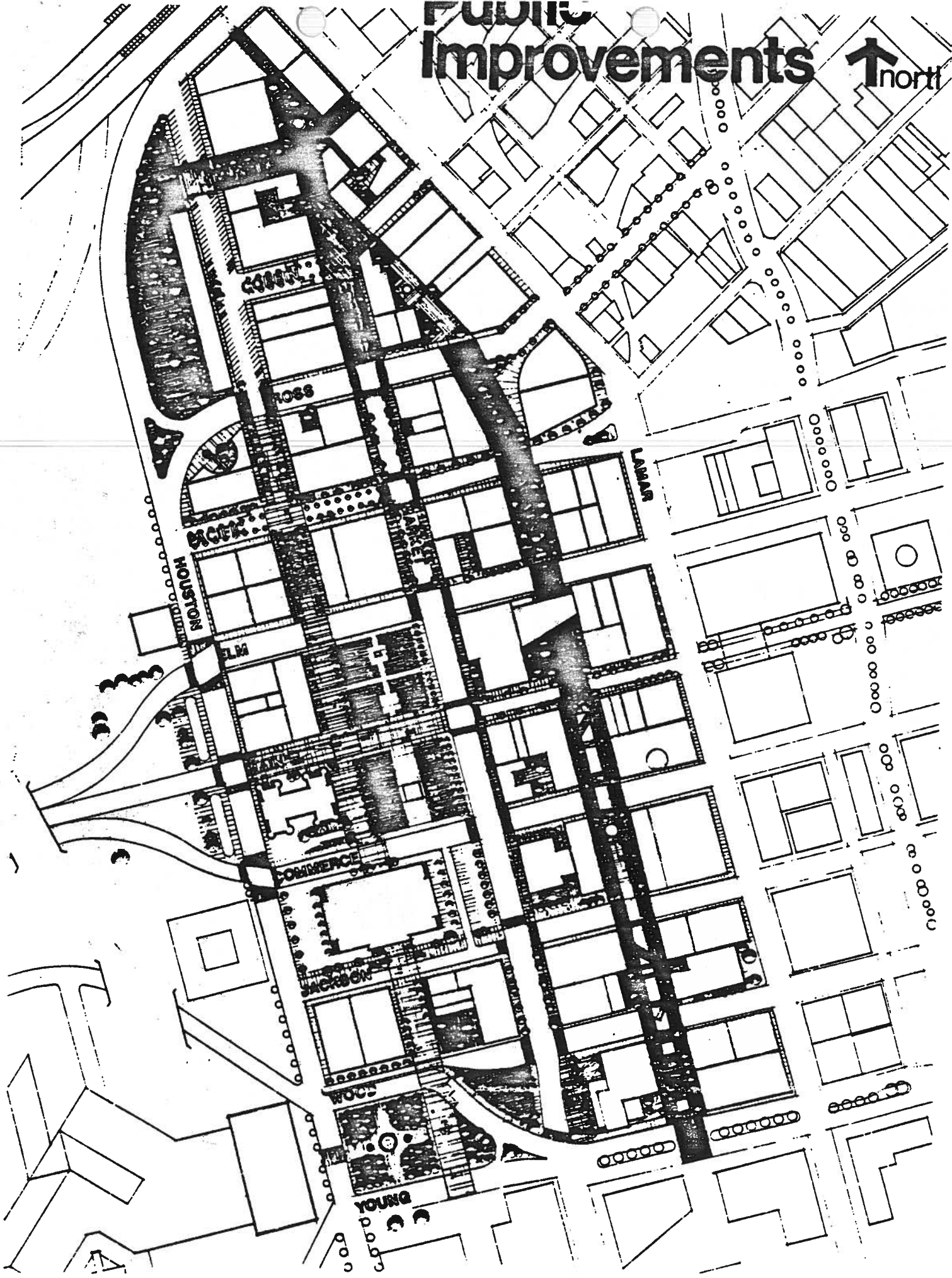



## ECONOMIC ADVANTAGES

Recycling buildings for alternate uses is not a new phenomenon. Cities and towns across the country have been doing this for many years. Warehouse buildings, similar in style to those found in the Westend, comprise many of the buildings of the New York University campus. The old Brooklyn Paramount now serves as the Long Island University sports-auditorium complex. A former piano factory in Boston is now an apartment complex. Old warehouses from Boston to San Francisco have been transformed to residences, artists lofts, shops and office space.

---

Locally, SEDCO Corporation (1901 N. Akard) has had a dramatic visual impact on the downtown area with the striking renovation of the Old Cumberland School for their corporate headquarters. The Old Red Courthouse (Houston at Main) currently serves as office space for County services. The Gran Crystal Palace (2424 Swiss Avenue) and the Old Spaghetti Warehouse (1815 N. Market) are examples of the broad scope of possible reuses for warehouse facilities. Recycling has repeatedly demonstrated its economic validity.

Now there are new incentives for preservation. The New Federal Tax Act (October, 1976) provides for substantial incentives for preservation of certified historic structures that are rehabilitated for commercial purposes. Additionally, inclusion on the National Register of Historic Places provides for eligibility for matching grants for renovation work.

Interested persons are advised to consult with the Dallas Historic Landmark Preservation Committee and Department of Urban Planning for additional sources of funding information, ideas and potential sources of information.

## SOURCE MATERIALS

There is a great deal of literature currently available on the subject of recycling. The best beginning point would be to establish contact with the National Trust for Historic Preservation, 740-748 Jackson Place, N.W., Washington, D. C. 20006, (202) 382-3304. This private, nonprofit organization is the only group chartered by Congress for the purpose of promoting the preservation, restoration and recycling of older structures.

The Preservation Bookstore Catalogue lists many standard reference works (discounts are offered to Trust members). Membership in the Trust (\$15 individual; \$25 organizations) provides for the monthly newspaper and quarterly journal.

Specific National Trust Publications of interest include the following:

Preservation & Building Codes - \$4.00

Economic Benefits of Preserving Old Buildings - \$5.50

"New Life for Old Buildings" - Preservation News Supplement, April, 1973