

**APRIL 27, 2016 CITY COUNCIL ADDENDUM  
CERTIFICATION**

This certification is given pursuant to Chapter XI, Section 9 of the City Charter for the City Council Addendum dated April 27, 2016. We hereby certify, as to those contracts, agreements, or other obligations on this Agenda authorized by the City Council for which expenditures of money by the City are required, that all of the money required for those contracts, agreements, and other obligations is in the City treasury to the credit of the fund or funds from which the money is to be drawn, as required and permitted by the City Charter, and that the money is not appropriated for any other purpose.



---

A.C. Gonzalez  
City Manager

4.22.16

---

Date



---

Jeanne Chipperfield  
Chief Financial Officer

4/22/16

---

Date



**RECEIVED**

2016 APR 22 PM 4: 07

CITY SECRETARY  
DALLAS, TEXAS

**ADDENDUM  
CITY COUNCIL MEETING  
WEDNESDAY, APRIL 27, 2016  
CITY OF DALLAS  
1500 MARILLA  
COUNCIL CHAMBERS, CITY HALL  
DALLAS, TX 75201  
9:00 A.M.**

**REVISED ORDER OF BUSINESS**

Agenda items for which individuals have registered to speak will be considered no earlier than the time indicated below:

9:00 a.m.      **INVOCATION AND PLEDGE OF ALLEGIANCE**

**OPEN MICROPHONE**

**CLOSED SESSION**

**MINUTES**

Item 1

**CONSENT AGENDA**

Items 2 - 52

**CONSENT ADDENDUM**

Items 1 - 6

**ITEMS FOR INDIVIDUAL CONSIDERATION**

No earlier  
than 9:15 a.m.

Items 53 - 59  
Addendum Items 7 - 8

**PUBLIC HEARINGS AND RELATED ACTIONS**

1:00 p.m.

Items 60 - 71

# SUPPLEMENTAL NOTICE

"Pursuant to Section 30.06, Penal Code (trespass by license holder with a concealed handgun), a person licensed under Subchapter H, Chapter 411, Government Code (handgun licensing law), may not enter this property with a concealed handgun."

*"De acuerdo con la sección 30.06 del código penal (ingreso sin autorización de un titular de una licencia con una pistola oculta), una persona con licencia según el subcapítulo h, capítulo 411, código del gobierno (ley sobre licencias para portar pistolas), no puede ingresar a esta propiedad con una pistola oculta."*

"Pursuant to Section 30.07, Penal Code (trespass by license holder with an openly carried handgun), a person licensed under Subchapter H, Chapter 411, Government Code (handgun licensing law), may not enter this property with a handgun that is carried openly."

*"De acuerdo con la sección 30.07 del código penal (ingreso sin autorización de un titular de una licencia con una pistola a la vista), una persona con licencia según el subcapítulo h, capítulo 411, código del gobierno (ley sobre licencias para portar pistolas), no puede ingresar a esta propiedad con una pistola a la vista."*

**ADDENDUM  
CITY COUNCIL MEETING  
APRIL 27, 2016  
CITY OF DALLAS  
1500 MARILLA  
COUNCIL CHAMBERS, CITY HALL  
DALLAS, TEXAS 75201  
9:00 A. M.**

ADDITIONS:

Closed Session

Personnel (Sec. 551.074 T.O.M.A.)

- Discussion on the status of the hiring and selection of a candidate for the position of city attorney.

CONSENT ADDENDUM

**Business Development & Procurement Services**

1. Authorize a two-year service contract for **(1)** hazardous and non-hazardous waste disposal services - Green Planet, Inc. in the amount of \$3,188,960 through Dallas/Fort Worth International Airport contract using the Interlocal Purchasing Agreement; and **(2)** bio-hazardous decontamination and spill clean-up services - Protect Environmental Services, Inc. in the amount of \$261,200 through the City of Richardson contract using the Interlocal Purchasing Agreement - Total not to exceed \$3,450,160 - Financing: Current Funds (\$2,966,024), Stormwater Drainage Management Current Funds (\$311,636), Water Utilities Current Funds (\$80,000), Sanitation Current Funds (\$50,000), Aviation Current Funds (\$40,000) and Convention and Event Services Current Funds (\$2,500) (subject to annual appropriations)
2. Authorize **(1)** the rejection of a single proposal received for a one-year service contract for a clinical dental care program; and **(2)** the re-advertisement for new proposals - Financing: No cost consideration to the City

**Park & Recreation**

3. Authorize a twenty-year development, operation, and maintenance agreement with Dallas Hartford, L.L.C. for the development, operation, and maintenance of parkland for Federal Plaza located at 1900 Federal Street – Financing: No cost consideration to the City

**ADDENDUM  
CITY COUNCIL MEETING  
APRIL 27, 2016**

ADDITIONS: (Continued)

CONSENT ADDENDUM (Continued)

**Police**

4. Authorize **(1)** an application for and acceptance of the "Click It or Ticket" Mobilization Grant in the amount of \$99,990 from the Texas Department of Transportation for a safety belt enforcement initiative for the period April 28, 2016 through June 6, 2016; **(2)** a City contribution of pension and Federal Insurance Contributions Act costs in the amount of \$28,947; and **(3)** execution of the grant agreement - Total not to exceed \$128,937 - Financing: Current Funds (\$28,947) and Texas Department of Transportation Grant Funds (\$99,990)
5. Authorize Supplemental Agreement No. 8 to the contract with Xerox State and Local Solutions, Inc. (formerly ACS State and Local Solutions, Inc.) to extend the contract term from May 2, 2016 through August 2, 2016 for services related to meter operations and a parking management information system - Estimated Net Parking Revenue: \$1,875,000

**Sustainable Development and Construction**

6. An ordinance granting a GO(A) General Office District and a resolution accepting amended deed restrictions volunteered by the applicant on property zoned an MO-2 Mid-range Office District on the east side of Preston Road, south of Frankford Road - Z156-175 - Financing: No cost consideration to the City

ITEMS FOR INDIVIDUAL CONSIDERATION

**Mayor and City Council**

7. A resolution appointing Christopher D. Bowers, as Interim City Attorney for the City of Dallas, effective at the close of business on April 29, 2016, to serve until the City Council selects and appoints a permanent City Attorney - Financing: No cost consideration to the City

**Office of Financial Services**

8. A resolution ordering Oncor Electric Delivery Company, LLC to show cause regarding the reasonableness of its existing Transmission and Distribution rates within the City of Dallas - Financing: No cost consideration to the City

**ADDENDUM DATE April 27, 2016**

ITEM	IND	DEF	DISTRICT	TYPE	DEPT.	DOLLARS	LOCAL	MWBE	DESCRIPTION
#	OK								
1			All	C	PBD, AVI, CES, SAN, STS, TWM, WTR	\$3,450,160.00	NA	NA	Authorize a two-year service contract for (1) hazardous and non-hazardous waste disposal services - Green Planet, Inc. in the amount of \$3,188,960 through Dallas/Fort Worth International Airport contract using the Interlocal Purchasing Agreement; and (2) bio-hazardous decontamination and spill clean-up services - Protect Environmental Services, Inc. in the amount of \$261,200 through the City of Richardson contract using the Interlocal Purchasing Agreement - Total not to exceed \$3,450,160 - Financing: Current Funds (\$2,966,024), Stormwater Drainage Management Current Funds (\$311,636), Water Utilities Current Funds (\$80,000), Sanitation Current Funds (\$50,000), Aviation Current Funds (\$40,000) and Convention and Event Services Current Funds (\$2,500) (subject to annual appropriations)
2			All	C	PBD, HOU	NC	NA	NA	Authorize (1) the rejection of a single proposal received for a one-year service contract for a clinical dental care program; and (2) the re-advertisement for new proposals - Financing: No cost consideration to the City
3			14	C	PKR	NC	NA	NA	Authorize a twenty-year development, operation, and maintenance agreement with Dallas Hartford, L.L.C. for the development, operation, and maintenance of parkland for Federal Plaza located at 1900 Federal Street - Financing: No cost consideration to the City
4			All	C	POL	\$28,947.00	NA	NA	Authorize (1) an application for and acceptance of the "Click It or Ticket" Mobilization Grant in the amount of \$99,990 from the Texas Department of Transportation for a safety belt enforcement initiative for the period April 28, 2016 through June 6, 2016; (2) a City contribution of pension and Federal Insurance Contributions Act costs in the amount of \$28,947; and (3) execution of the grant agreement - Total not to exceed \$128,937 - Financing: Current Funds (\$28,947) and Texas Department of Transportation Grant Funds (\$99,990)
5			N/A	C	POL	REV \$1,875,000	NA	NA	Authorize Supplemental Agreement No. 8 to the contract with Xerox State and Local Solutions, Inc. (formerly ACS State and Local Solutions, Inc.) to extend the contract term from May 2, 2016 through August 2, 2016 for services related to meter operations and a parking management information system - Estimated Net Parking Revenue: \$1,875,000
6			12	C	DEV	NC	NA	NA	An ordinance granting a GO(A) General Office District and a resolution accepting amended deed restrictions volunteered by the applicant on property zoned an MO-2 Mid-range Office District on the east side of Preston Road, south of Frankford Road - Z156-175 - Financing: No cost consideration to the City
7			All	I	MCC	NC	NA	NA	A resolution appointing Christopher D. Bowers, as Interim City Attorney for the City of Dallas, effective at the close of business on April 29, 2016, to serve until the City Council selects and appoints a permanent City Attorney - Financing: No cost consideration to the City
8			N/A	I	OFS	NC	NA	NA	A resolution ordering Oncor Electric Delivery Company, LLC to show cause regarding the reasonableness of its existing Transmission and Distribution rates within the City of Dallas - Financing: No cost consideration to the City

**TOTAL            \$3,479,107.00**





**ADDENDUM ITEM # 1**

**KEY FOCUS AREA:** E-Gov

**AGENDA DATE:** April 27, 2016

**COUNCIL DISTRICT(S):** All

**DEPARTMENT:** Business Development & Procurement Services  
Aviation  
Convention and Event Services  
Sanitation Services  
Street Services  
Trinity Watershed Management  
Water Utilities

**CMO:** Jeanne Chipperfield, 670-7804  
Ryan S. Evans, 671-9837  
Joey Zapata, 670-3009  
Jill A. Jordan, P.E., 670-5299  
Mark McDaniel, 670-3256

**MAPSCO:** N/A

---

**SUBJECT**

Authorize a two-year service contract for **(1)** hazardous and non-hazardous waste disposal services - Green Planet, Inc. in the amount of \$3,188,960 through Dallas/Fort Worth International Airport contract using the Interlocal Purchasing Agreement; and **(2)** bio-hazardous decontamination and spill clean-up services - Protect Environmental Services, Inc. in the amount of \$261,200 through the City of Richardson contract using the Interlocal Purchasing Agreement - Total not to exceed \$3,450,160 - Financing: Current Funds (\$2,966,024), Stormwater Drainage Management Current Funds (\$311,636), Water Utilities Current Funds (\$80,000), Sanitation Current Funds (\$50,000), Aviation Current Funds (\$40,000) and Convention and Event Services Current Funds (\$2,500) (subject to annual appropriations)

**BACKGROUND**

This item is was placed on the addendum to allow for immediate waste disposal and decontamination services.

This action will authorize service contracts for hazardous and non-hazardous waste disposal and bio-hazardous decontamination and spill clean-up services for the City.

## **BACKGROUND (Continued)**

These contracts will be used for the disposal of confiscated, biologically hazardous, environmentally hazardous and non-hazardous materials such as:

- Blood
- Body fluids
- Corrosive/flammable materials
- Liquor, beer and wine
- Ammunition and fireworks
- Automobile and equipment solid batteries

Also included in these contracts is the collection and disposing of used and spilled cleaning materials, paints and pesticides to avoid City employee exposure to such materials and to ensure compliance with the Environmental Management Program. These products need to be disposed in accordance with specifications for toxic hazardous substances separately from the City's regular solid waste pickup and materials recycling. The recommended vendors meet the wage floor rate of \$10.37 approved by City Council on November 10, 2015, by Resolution No. 15-2141.

## **PRIOR ACTION/REVIEW (COUNCIL, BOARDS, COMMISSIONS)**

On February 26, 2014, City Council authorized Supplemental Agreement No. 3 to increase the service contract for hazardous and non-hazardous material clean-up and disposal services for City departments to extend the contract term through December 18, 2014, by Resolution No. 14-0370.

On December 10, 2014, City Council authorized a service contract with Green Planet, Inc. through a Cooperative Purchasing Agreement with Dallas/Fort Worth International Airport for hazardous and non-hazardous waste disposal services for a term of one year, by Resolution No. 14-2084.

Information about this item will be provided to the Quality of Life & Environment Committee on April 25, 2016.

## **FISCAL INFORMATION**

\$2,966,024.00 - Current Funds (subject to annual appropriations)  
\$ 311,636.00 - Stormwater Drainage Management Current Funds (subject to annual appropriations)  
\$ 80,000.00 - Water Utilities Current Funds (subject to annual appropriations)  
\$ 50,000.00 - Sanitation Current Funds (subject to annual appropriations)  
\$ 40,000.00 - Aviation Current Funds (subject to annual appropriations)  
\$ 2,500.00 - Convention and Event Services Current Funds (subject to annual appropriations)

**ETHNIC COMPOSITION**

Green Planet, Inc.

White Male	3	White Female	2
Black Male	0	Black Female	0
Hispanic Male	4	Hispanic Female	0
Other Male	1	Other Female	0

Protect Environmental Services, Inc.

White Male	19	White Female	9
Black Male	2	Black Female	0
Hispanic Male	4	Hispanic Female	2
Other Male	0	Other Female	0

**OWNERS**

**Green Planet, Inc.**

Virginia Belmore, President  
Hassan Aicha, Vice President

**Protect Environmental Services, Inc.**

A. Kirsten Cameron, President

April 27, 2016

**WHEREAS**, on February 26, 2014, City Council authorized Supplemental Agreement No. 3 to increase the service contract for hazardous and non-hazardous material clean-up and disposal services for City departments to extend the contract term through December 18, 2014, by Resolution No. 14-0370; and

**WHEREAS**, on December 10, 2014, City Council authorized a service contract with Green Planet, Inc. through a Cooperative Purchasing Agreement with Dallas/Fort Worth International Airport for hazardous and non-hazardous waste disposal services for a term of one year by Resolution No. 14-2084;

**NOW, THEREFORE,**

**BE IT RESOLVED BY THE CITY COUNCIL OF THE CITY OF DALLAS:**

**Section 1.** That the City Manager is authorized to execute a service contract with (1) Green Planet, Inc. (357112) through Dallas/Fort Worth International Airport procurement contract No. 7005553 Change Order No. 5 in accordance with the Interlocal Purchasing Agreement with Dallas/Fort Worth International Airport in the amount of \$3,188,960.00 for hazardous and non-hazardous waste disposal services; and (2) Protect Environmental Services, Inc. (VS0000039052) through the agreement from Request for Bid 41-14 by the City of Richardson in accordance with the Interlocal Purchasing Agreement in the amount of \$261,200.00 for bio-hazardous decontamination and spill clean-up services for a term of two years in a total amount not to exceed \$3,450,160.00, upon approval as to form by the City Attorney. If the service was bid or proposed on an as needed, unit price basis for performance of specified tasks, payment to Green Planet, Inc. and Protect Environmental Services, Inc. shall be based only on the amount of the services directed to be performed by the City and properly performed by Green Planet, Inc. and Protect Environmental Services, Inc. under the contract.

**Section 2.** That the Chief Financial Officer is hereby authorized to disburse funds in an amount not to exceed \$3,450,160.00 (subject to annual appropriations) from Service Contract number BW1601.

**Section 3.** That this resolution shall take effect immediately from and after its passage in accordance with the provisions of the Charter of the City of Dallas, and it is accordingly so resolved.

**ADDENDUM ITEM # 2**

**KEY FOCUS AREA:** Clean, Healthy Environment

**AGENDA DATE:** April 27, 2016

**COUNCIL DISTRICT(S):** All

**DEPARTMENT:** Business Development & Procurement Services  
Housing/Community Services

**CMO:** Jeanne Chipperfield, 670-7804  
Alan Sims, Chief of Neighborhood Plus, 670-1611

**MAPSCO:** N/A

---

**SUBJECT**

Authorize **(1)** the rejection of a single proposal received for a one-year service contract for a clinical dental care program; and **(2)** the re-advertisement for new proposals - Financing: No cost consideration to the City

**BACKGROUND**

This item is on the addendum to complete a new solicitation process utilizing FY16 grant funds.

This action will authorize the rejection of a single proposal received for solicitation BTZ1523 for a one-year service contract for a clinical dental care program. Housing/Community Services will modify the specifications. Housing/Community Services further determined it would be more advantageous to the City to reject the single proposal and re-advertise a new solicitation to encourage more competition.

**PRIOR ACTION/REVIEW (COUNCIL, BOARDS, COMMISSIONS)**

Information about this item was provided to the Housing Committee on April 18, 2016.

**FISCAL INFORMATION**

No cost consideration to the City.

April 27, 2016

**WHEREAS**, on September 17, 2015, a single proposal was received for a one-year service contract for a clinical dental care program; and,

**WHEREAS**, it has been determined that it is in the best interest of the City of Dallas to reject the single proposal that was received for a one-year service contract for a clinical dental care program;

**NOW, THEREFORE,**

**BE IT RESOLVED BY THE CITY COUNCIL OF THE CITY OF DALLAS:**

**Section 1.** That the single proposal received for a one-year service contract for a clinical dental care program is hereby rejected and authorization to solicit new proposals is granted.

**Section 2.** That this resolution shall take effect immediately from and after its passage in accordance with the provisions of the Charter of the City of Dallas, and it is accordingly so resolved.

**ADDENDUM ITEM # 3**

**KEY FOCUS AREA:** Culture, Arts and Recreation and Educational Enhancements

**AGENDA DATE:** April 27, 2016

**COUNCIL DISTRICT(S):** 14

**DEPARTMENT:** Park & Recreation

**CMO:** Willis Winters, 670-4071

**MAPSCO:** 45-L

---

**SUBJECT**

Authorize a twenty-year development, operation, and maintenance agreement with Dallas Hartford, L.L.C. for the development, operation, and maintenance of parkland for Federal Plaza located at 1900 Federal Street – Financing: No cost consideration to the City

**BACKGROUND**

This item was scheduled for the Council consent agenda but is being placed on the addendum since the Park and Recreation Board deferred the item on April 7, 2016 to the next Park and Recreation Board meeting on April 21, 2016, in order to allow staff to produce additional information. Placing the item on the addendum will allow the Park and Recreation Department to pull the item if it is not approved by Park and Recreation Board on April 21, 2016. The TIF Board requires that the construction requirements of the agreement be completed by the end of June, hence a delay in Council approval will make it impossible to meet this deadline.

This action will authorize a development, operation, and maintenance agreement with Dallas Hartford, L.L.C. (Dallas Hartford) for the renovation, operation, and maintenance of Federal Plaza located at 1900 Federal Street.

On March 26, 2014, Resolutions Nos. 14-0526 and 14-0527, approved a development agreement with and expenditure of TIF funds for Dallas Hartford, such funds being supportive of redevelopment of the City Center TIF District. In addition to a minimum private investment of \$5,000,000 in the redevelopment of the 400 North St Paul Street Hartford Building, an Urban Design Peer Review Panel (UDPRP), appointed by the City Manager, required Dallas Hartford to:

- a. Include the adjacent park (Federal Plaza) in the project scope.
- b. Create linkages between the park and the renovated building through selection of materials, lighting, landscaping, and a shade structure.

**BACKGROUND** (Continued)

- c. Consider the potential impact of the future trolley alignment on design of the park and the public area adjacent to the building.

Such recommendations by UDPRP, and expenditure of TIF funds, are consistent with TIF Project requirements for development and redevelopment for improvement to a space for public benefit, such as City parks, open space, trails, or cultural facilities.

The agreement with the Park Board will be subject to the following terms:

1. The term is for 20 years.
2. Dallas Hartford, at its own cost, is responsible for the development of the design, plans, and specifications for the improvements to be made to the park (Exhibit B attached to the resolution). Dallas Hartford will submit the design to the Park and Recreation Department for review and approval prior to commencement of construction.
3. Dallas Hartford, at their own cost, is responsible for the operation, maintenance, and repair of the park during the term of the agreement.
4. Dallas Hartford will manage the design and construction through its own consultants and contractors and will be responsible for all permits and other approvals. All consultants and contractors are required to provide insurance that is consistent with what is required by City consultants and contractors.
5. The City of Dallas will retain the right to require Dallas Hartford to modify the improvements if and when necessary to maintain public safety of the parkland.

**PRIOR ACTION/REVIEW (COUNCIL, BOARDS, COMMISSIONS)**

On March 26, 2014, Council authorized a development agreement with Dallas Hartford to reimburse eligible project costs, by Resolution No. 14-0526.

On March 26, 2014, Council authorized reimbursement to Dallas Hartford from TIF funds, by Resolution No. 14-0527.

The Park and Recreation Board deferred this item on April 7, 2016.

The Park and Recreation Board approved this item on April 21, 2016.

Information about this item will be provided to the Quality of Life & Environment Committee on April 25, 2016.



**FISCAL INFORMATION**

No cost consideration to the City.

**MAP**

Attached

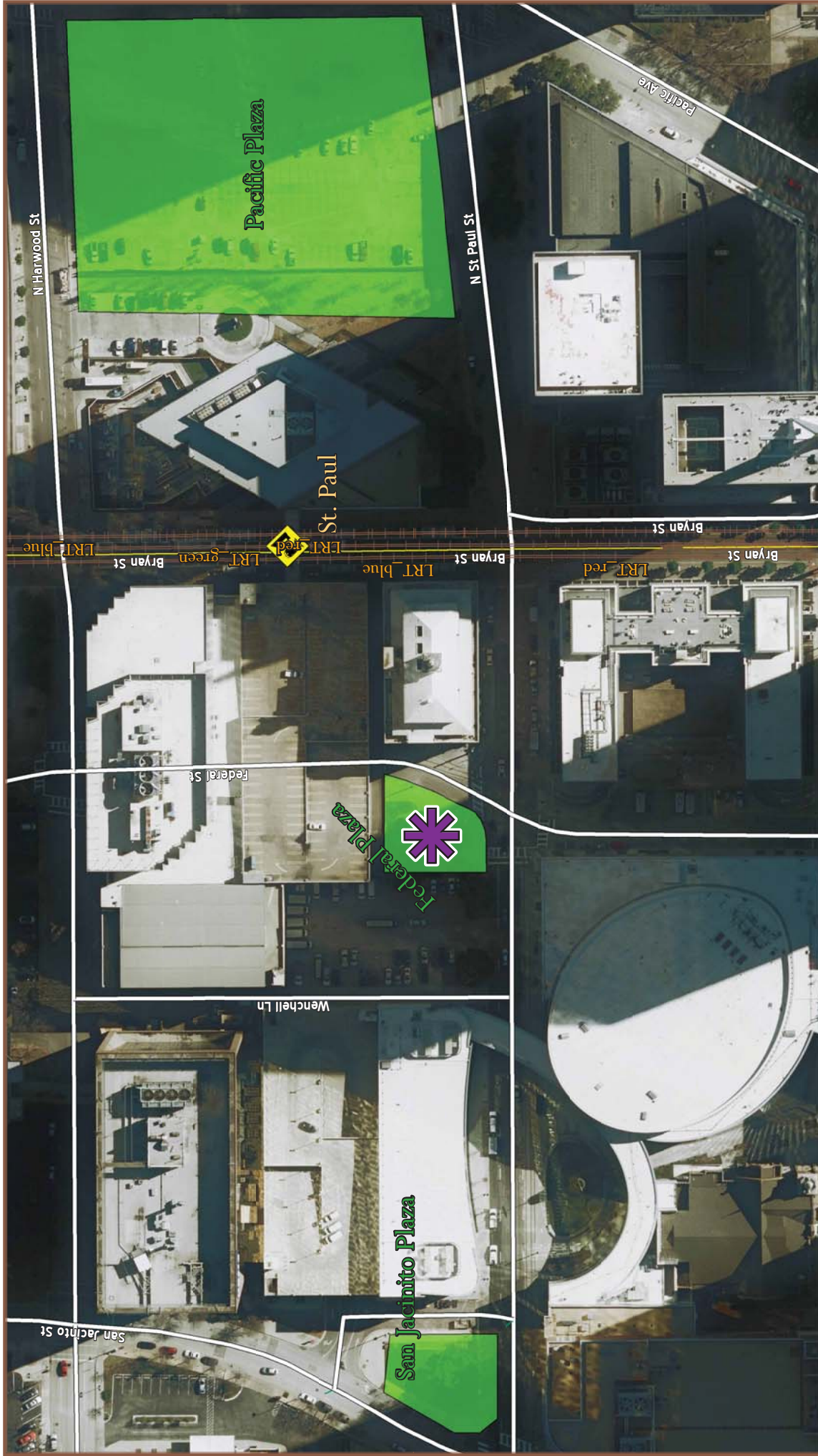

# Federal Plaza (1900 Federal Street)

Mapsc0  
45 L

District  
14

April 7, 2016

April 27, 2016

**WHEREAS**, the City Charter provides for the Park and Recreation Board to grant contracts and agreements within park facilities with such terms and conditions as it shall deem proper; and

**WHEREAS**, the City of Dallas Park and Recreation Department (City) and Dallas Hartford, L.L.C. (Dallas Hartford), a Texas limited liability company, desire to enter into a development and maintenance agreement for the purpose of development, operation, and maintenance of parkland at Federal Plaza located at 1900 Federal Street shown in Exhibits A and B; and

**WHEREAS**, the City desires to have Dallas Hartford develop, operate, and maintain parkland during the Term of the Agreement for use and enjoyment of all city of Dallas citizens.

**Now, Therefore,**

**BE IT RESOLVED BY THE PARK AND RECREATION BOARD AND THE CITY COUNCIL OF THE CITY OF DALLAS:**

**SECTION 1.** That the City Manager is hereby authorized to enter into a twenty-year development, operation and maintenance agreement with Dallas Hartford for the development, operation and maintenance of Federal Plaza.

**SECTION 2.** That the President of the Park and Recreation Board and City Manager are hereby authorized to execute a development, operation and maintenance agreement with Dallas Hartford, after approval as to form by the City Attorney.

**SECTION 3.** That the duration of the agreement will be for a term of 20 years.

**SECTION 4.** That this resolution shall take effect immediately from and after its passage in accordance with the provisions of the Charter of the City of Dallas, and it is accordingly so resolved.

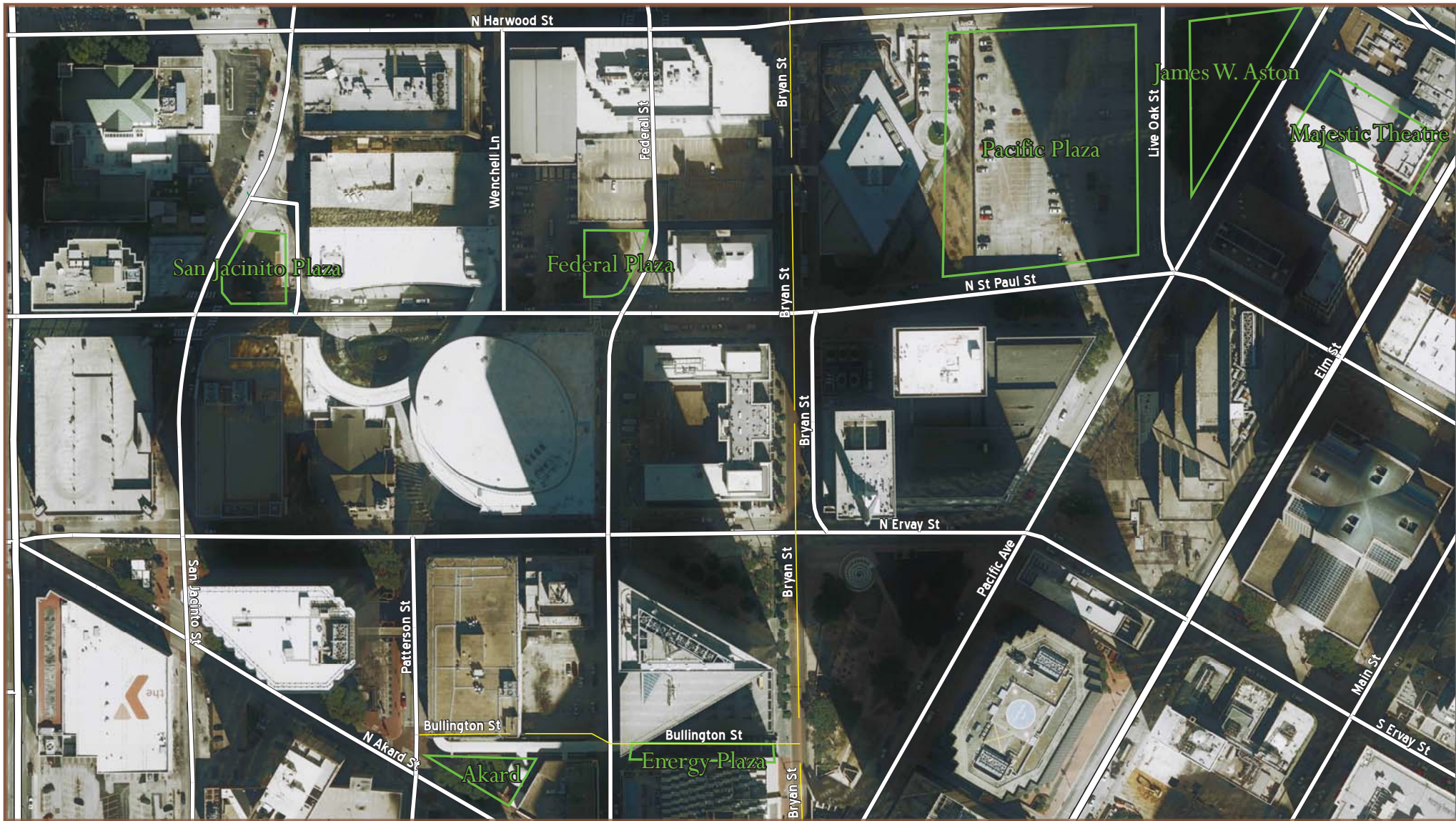

March 10, 2016

### Federal Plaza

Exhibit A  
page 1 of 2



March 10, 2016

## *Federal Plaza*

*Exhibit A*

*page 2 of 2*

October 30, 2013

REVISION:
November 16, 2015

**Exhibit B**  
 Park Improvements

**Hartford Park**  
 400 N. ST. PAUL ST. DALLAS TEXAS 75201

FLOOR PLAN / SECTIONS

**A-1**



Cor-Tin Fence



Concrete - Rock Salt Finish

02 | MATERIAL IMAGES  
 3/4"=1'-0"

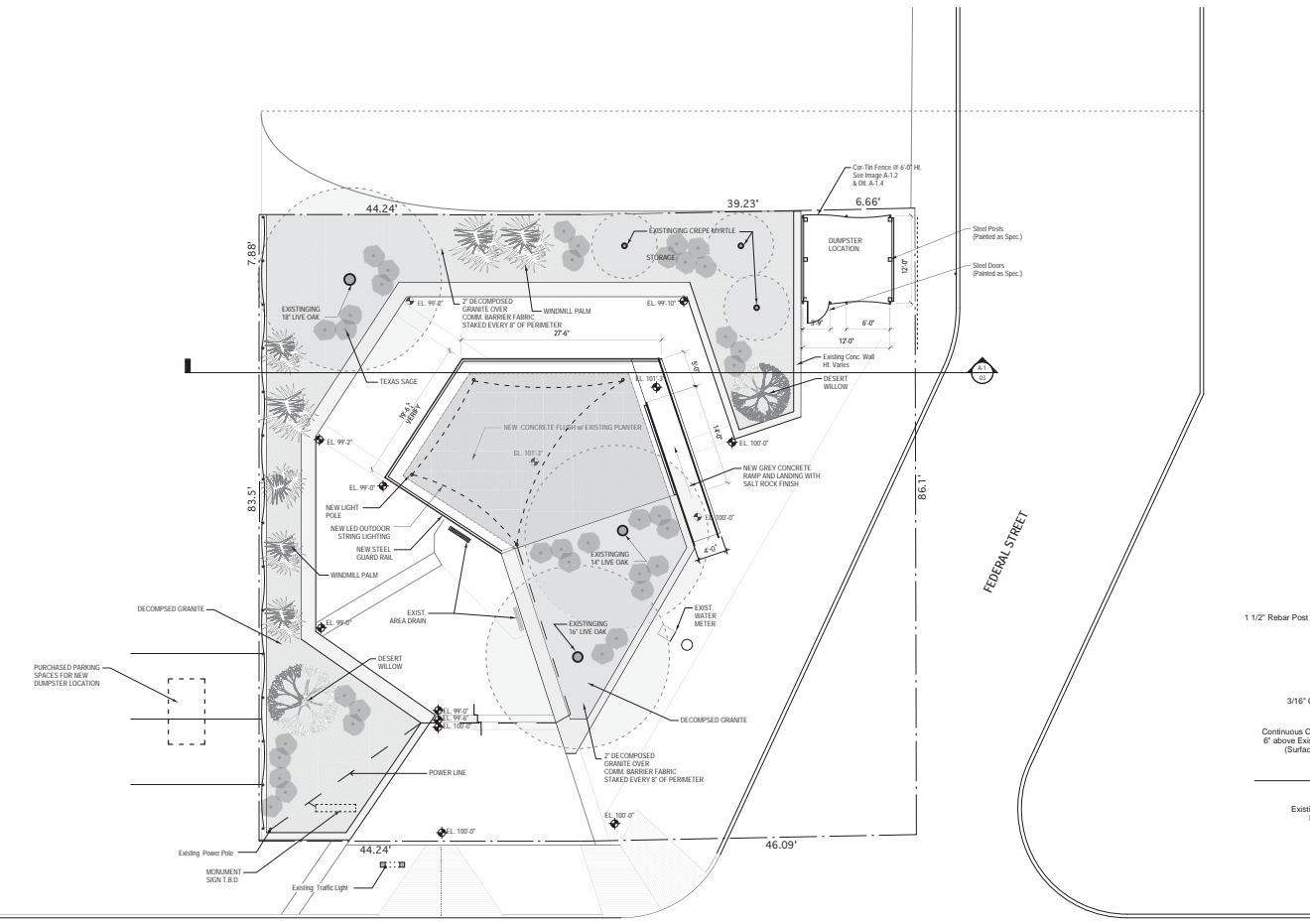

ST. PAUL STREET

01 | SITE PLAN  
 1/8"=1'-0"

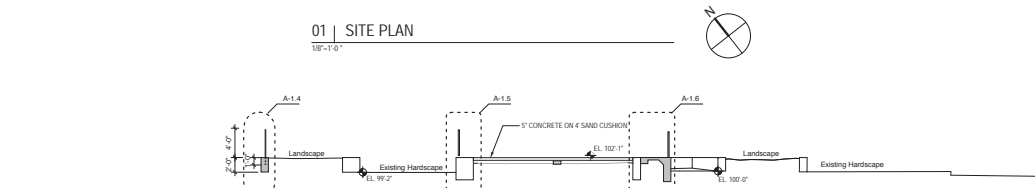

03 | SITE SECTION  
 1/8"=1'-0"

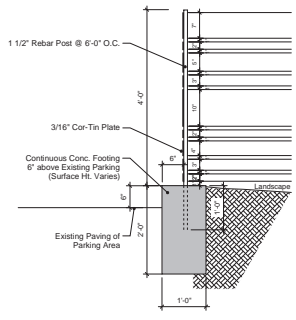

04 | SECTION DETAIL  
 3/4"=1'-0"

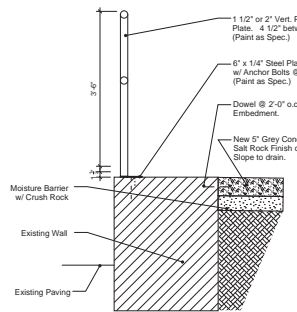

05 | SECTION DETAIL  
 3/4"=1'-0"

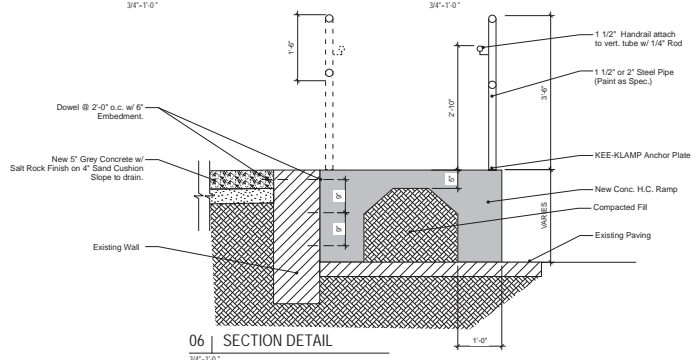

06 | SECTION DETAIL  
 3/4"=1'-0"

**KEY FOCUS AREA:** Public Safety  
**AGENDA DATE:** April 27, 2016  
**COUNCIL DISTRICT(S):** All  
**DEPARTMENT:** Police  
**CMO:** Eric Campbell, 670-3255  
**MAPSCO:** N/A

---

**SUBJECT**

Authorize **(1)** an application for and acceptance of the “Click It or Ticket” Mobilization Grant in the amount of \$99,990 from the Texas Department of Transportation for a safety belt enforcement initiative for the period April 28, 2016 through June 6, 2016; **(2)** a City contribution of pension and Federal Insurance Contributions Act costs in the amount of \$28,947; and **(3)** execution of the grant agreement - Total not to exceed \$128,937 - Financing: Current Funds (\$28,947) and Texas Department of Transportation Grant Funds (\$99,990)

**BACKGROUND**

This item was placed on the addendum due to the late award notification and the requirement that City Council approve it before funds can be issued to this grant for enforcement period April 28, 2016 through June 6, 2016.

The Texas Department of Transportation (TxDOT) issued an award notification to the Dallas Police Department on April 12, 2016. This award has been granted for April 28, 2016 through June 6, 2016. TxDOT requires approval from City Council for acceptance of this grant award before funds can be issued for this program. The Click It or Ticket Grant provides for the reimbursement of overtime salaries paid to officers enforcing Seatbelt and Child Safety Seat laws at locations throughout the City of Dallas.

This grant is one of the “wave” grants from TxDOT that are part of the national traffic safety plan and are awarded to TxDOT grant recipients. The grant is for the increased enforcement of Seatbelt and Child Safety Seat laws during the national campaign of April 28, 2016 through June 6, 2016 (enforcement period).

**PRIOR ACTION/REVIEW (Council, Boards, Commissions)**

Authorized an application for and acceptance of the “Click It or Ticket” Mobilization grant from the Texas Department of Transportation for a safety belt initiative on April 22, 2009, by Resolution No. 09-1072.

**PRIOR ACTION/REVIEW (Council, Boards, Commissions)** (Continued)

Authorized an application for and acceptance of the “Click It or Ticket” Mobilization grant from the Texas Department of Transportation for a safety belt initiative on October 14, 2009, by Resolution No. 09-2527.

Authorized an application for and acceptance of the “Click It or Ticket” Mobilization grant from the Texas Department of Transportation for a safety belt initiative on May 9, 2012, by Resolution No. 12-1267.

Authorized an application for and acceptance of the “Click It or Ticket” Mobilization grant from the Texas Department of Transportation for a safety belt initiative on May 22, 2013, by Resolution No. 13-0828.

Authorized an application for and acceptance of the “Click It or Ticket” Mobilization grant from the Texas Department of Transportation for a safety belt initiative on May 14, 2014, by Resolution No. 14-0756.

Authorized an application for and acceptance of the “Click It or Ticket” Mobilization grant from the Texas Department of Transportation for a safety belt initiative on May 13, 2015, by Resolution No. 15-0843.

Information about this item will be provided to the Public Safety Committee on April 25, 2016.

**FISCAL INFORMATION**

\$ 99,989.40 - Texas Department of Transportation Grant Funds

\$ 28,947.00 - Current Funds



April 27, 2016

**WHEREAS**, City Council authorized an application for and acceptance of the "Click It or Ticket" Mobilization grant from the Texas Department of Transportation for a safety belt initiative on May 13, 2015, by Resolution No. 15-0843; and

**WHEREAS**, the Texas Department of Transportation has made the "Click It or Ticket" Mobilization Grant funds available for overtime salaries for a safety belt enforcement initiative for the period April 28, 2016 through June 6, 2016; and

**WHEREAS**, the "Click It or Ticket" Mobilization Grant will provide \$99,989.40; and

**WHEREAS**, the City of Dallas contributes pension and FICA costs related to the overtime in an amount not to exceed \$28,947.00; and

**WHEREAS**, it is in the best interest of the City of Dallas to apply for and accept such funding.

**Now, Therefore,**

**BE IT RESOLVED BY THE CITY COUNCIL OF THE CITY OF DALLAS:**

**Section 1.** That the City Manager is hereby authorized to apply for and accept the "Click It or Ticket" Mobilization Grant No. 2016-Dallas-CIOT-00033, CFDA No. 20.616, from the Texas Department of Transportation through a grant from the National Highway Traffic Safety Administration for the safety belt enforcement initiative for the period April 28, 2016 through June 6, 2016 in an amount not to exceed \$99,989.40, after it has been approved as to form by the City Attorney.

**Section 2.** That the Chief Financial Officer is hereby authorized to receive and deposit grant funds into Fund F487, Department DPD, Unit 1945, Revenue Source Code 6506, in an amount not to exceed \$99,989.40.

**Section 3.** That the City Manager is hereby authorized to establish appropriations for the "Click It or Ticket" Mobilization Grant in an amount not to exceed \$99,989.40, in Fund F487, Department DPD, Unit 1945, Object Code 3090.

**Section 4.** That the Chief Financial Officer is hereby authorized to reimburse funds in an amount not to exceed \$99,989.40 from Fund F487, Department DPD, Unit 1945, Object Code 3090 to Fund 0001, Department DPD, Unit 2127, Object Code 5011 after the overtime expenditure is incurred.

**Section 5.** That the Chief Financial Officer is hereby authorized to disburse funds for City's pension contribution and Federal Insurance Contributions Act costs related to the overtime expenditure, in an amount not to exceed \$28,947.00 from Current Fund 0001, Dept. DPD, Unit 2127, Object codes 1302 and 1306.

April 27, 2016

**Section 6.** That the City Manager is hereby authorized to reimburse the granting agency any expenditures identified as ineligible and notify the appropriate City Council Committee of expenditures identified as ineligible not later than 30 days after the reimbursement.

**Section 7.** That the City Manager shall keep the appropriate City Council Committee informed of all final granting agency monitoring reports not later than 30 days after the receipt of the report.

**Section 8.** That this resolution shall take effect immediately from and after its passage in accordance with the provisions of the Charter of the City of Dallas, and it is accordingly so resolved.

**KEY FOCUS AREA:** Public Safety  
**AGENDA DATE:** April 27, 2016  
**COUNCIL DISTRICT(S):** N/A  
**DEPARTMENT:** Police  
**CMO:** Eric Campbell, 670-3255  
**MAPSCO:** N/A

---

**SUBJECT**

Authorize Supplemental Agreement No. 8 to the contract with Xerox State and Local Solutions, Inc. (formerly ACS State and Local Solutions, Inc.) to extend the contract term from May 2, 2016 through August 2, 2016 for services related to meter operations and a parking management information system - Estimated Net Parking Revenue: \$1,875,000

**BACKGROUND**

This item is on the addendum to continue parking management services without interruption.

This action does not encumber funds; the purpose of this service contract is to establish a firm pricing for services requested, for a specific term, which are paid from gross revenues collected.

The (3) month extension of the agreement with Xerox State and Local Solutions, Inc. will continue the existing services for operation of the parking system including: citations management and delinquent collections, meter and parking lot maintenance, meter collections, and customer service for a fixed monthly fee of \$267,379.33 for 3 months of services to be paid from gross revenues collected.

The (3) month extension will provide sufficient time to finalize the close of the current procurement process and transition to new service providers.

A component based Parking Services RFSCP was released in August 2015. The RFSCP allowed vendors to submit proposals for all (8) components or any single component. A turnkey option was available for components (1-5), as listed below, where vendors could offer lower pricing due to economies of scale. The City evaluated the proposals and will recommend award to the most advantageous proposer by component and/or turnkey, if applicable. The Components are listed below:

**BACKGROUND** (Continued)

Component 1	Citations Management
Component 2	Parking Management Services
Component 3	Parking Meter Maintenance
Component 4	Parking Meter Collections, Reconciliation, and Counting Services
Component 5	Parking Lot Maintenance
Component 6	Delinquent Collections
Component 7	Mobile Applications - Payments
Component 8	Mobile Applications - Mapping

Contract negotiations are underway with anticipated recommendation for City Council award in May 2016.

**PRIOR ACTION/REVIEW (COUNCIL, BOARDS, COMMISSIONS)**

Authorized contractual agreement with ACS State and Local Solutions, Inc. on April 27, 2005, by Resolution No. 05-1331.

Authorized Supplemental Agreement No. 1, on April 26, 2006, by Resolution No. 06-1220.

Authorized Supplemental Agreement No. 3, on May 12, 2010, by Resolution No. 10-1257.

Authorized Supplemental Agreement No. 4, on September 26, 2012, by Resolution No. 12-2426.

Authorized Supplemental Agreement No. 7, on March 25, 2015, by Resolution No. 15-0549.

Information about this item was provided to the Public Safety Committee on February 22, 2016.

Information about this item will be provided to the Public Safety Committee on April 25, 2016.

**FISCAL INFORMATION**

Estimated Net Parking Revenue: \$1,875,000

April 27, 2016

**WHEREAS**, on April 27, 2005, Resolution No. 05-1331 authorized two concurrent 5-year agreements and one 1-year renewal option with ACS State and Local Solutions, Inc., for the development and implementation of a turnkey Ticket Processing/Collections and Meter Operations program; and

**WHEREAS**, on April 26, 2006, as part of Supplemental Agreement No. 1, Resolution No. 06-1220 authorized the License Agreement with ACS State and Local Solutions, Inc., was amended to provide license recognition equipment and maintenance, staff and equipment for an auto pound payment station, and reimbursement to the City for two Boot Officers; and

**WHEREAS**, on April 12, 2007, as part of Supplemental Agreement No. 2, Administrative Action No. 07-1107 authorized the License Agreement with ACS State and Local Solutions, Inc., was amended to provide for the ability to adjust the revenue guarantee scale and alter the minimum guarantee; and

**WHEREAS**, on May 12, 2010, as part of Supplemental Agreement No. 3, Resolution No. 10-1257 authorized the License Agreement with ACS State and Local Solutions, Inc., was amended to provide for an additional five-year term for the Meter Operation and Parking Management Information System; and

**WHEREAS**, on September 26, 2012, as part of Supplemental Agreement No. 4, Resolution No. 12-2426 authorized the License Agreement with Xerox State and Local Solutions, Inc., was amended to provide for pay-by-phone or wireless application services for all metered parking spaces in the City; and

**WHEREAS**, on December 3, 2012, as part of Supplemental Agreement No. 5, Administrative Action No. 12-2862 authorized the License Agreement with Xerox State and Local Solutions, Inc., was amended to provide for the purchase of 10 multi-space meters and related items; and

**WHEREAS**, on June 10, 2014, as part of Supplemental Agreement No. 6, Administrative Action No. 14-6037 authorized the License Agreement with Xerox State and Local Solutions, Inc., was amended to provide for meter operations and parking system management of the Dallas Parking Technology Pilot; and

**WHEREAS**, on March 25, 2015, as part of Supplemental Agreement No. 7, Resolution No. 15-0549 authorized a one (1) year renewal option with Xerox State and Local Solutions, Inc., to provide for meter operations and parking management system; and

**WHEREAS**, in the City's best interest to extend the contract with Xerox State and Local Solutions, Inc. for a period of (3) three months from May 2, 2016 through August 2, 2016.

April 27, 2016

**Now, Therefore,**

**BE IT RESOLVED BY THE CITY COUNCIL OF THE CITY OF DALLAS:**

**Section 1.** That the City Manager is hereby authorized to extend the contract with Xerox State and Local Solutions, Inc. (Xerox) from May 2, 2016 through August 2, 2016 for services related to meter operations and a parking management information system.

**Section 2.** That the City Manager is hereby authorized to execute the agreement after it has been approved as to form by the City Attorney.

**Section 3.** That the Chief Financial Officer is hereby authorized to pay Xerox an amount not to exceed \$802,137.99 (\$267,379.33 monthly) from gross revenues collected for services related to meter operations and parking management information system for the period May 2, 2016 through August 2, 2016.

**Section 4.** That the Chief Financial Officer is hereby authorized to pay Xerox an amount not to exceed \$50,000 from gross revenues collected for program expenses related to warranty services, pilot expenses, and other general expenses for the period May 2, 2016 through August 2, 2016.

**Section 5.** That the Chief Financial Officer is hereby authorized to deposit revenues into Fund 0001, Dept DPD, Unit 2109, Revenue Source 8007, 8041, 8042, 8043, 7840, 6325.

**Section 6.** That this resolution shall take effect immediately from and after its passage in accordance with the provisions of the Charter of the City of Dallas, and it is accordingly so resolved.

**KEY FOCUS AREA:** Economic Vibrancy  
**AGENDA DATE:** April 27, 2016  
**COUNCIL DISTRICT(S):** 12  
**DEPARTMENT:** Sustainable Development and Construction  
**CMO:** Ryan S. Evans, 671-9837  
**MAPSCO:** 5 G

---

**SUBJECT**

An ordinance granting a GO(A) General Office District and a resolution accepting amended deed restrictions volunteered by the applicant on property zoned an MO-2 Mid-range Office District on the east side of Preston Road, south of Frankford Road - Z156-175 - Financing: No cost consideration to the City

**BACKGROUND**

This item is on the addendum as moved forward by Council direction.

On April 13, 2016, the City Council approved a GO(A) General Office District and a resolution accepting amended deed restrictions volunteered by the applicant on property zoned an MO-2 Mid-range Office District on the east side of Preston Road, south of Frankford Road with the ordinance and amended deed restrictions being brought back on April 27, 2016.

**PRIOR ACTION/REVIEW (COUNCIL, BOARD, COMMISSIONS)**

On March 3, 2016, the City Plan Commission recommended approval of a GO(A) General Office District on property zoned an MO-2 Mid-range Office District on the east side of Preston Road, south of Frankford Road.

On April 13, 2016, the City Council approved a GO(A) General Office District and a resolution accepting amended deed restrictions volunteered by the applicant on property zoned an MO-2 Mid-range Office District on the east side of Preston Road, south of Frankford Road with the ordinance and amended deed restrictions being brought back on April 27, 2016.

**FISCAL INFORMATION**

No cost consideration to the City.

**MAP**

Attached.



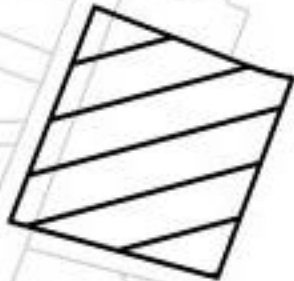
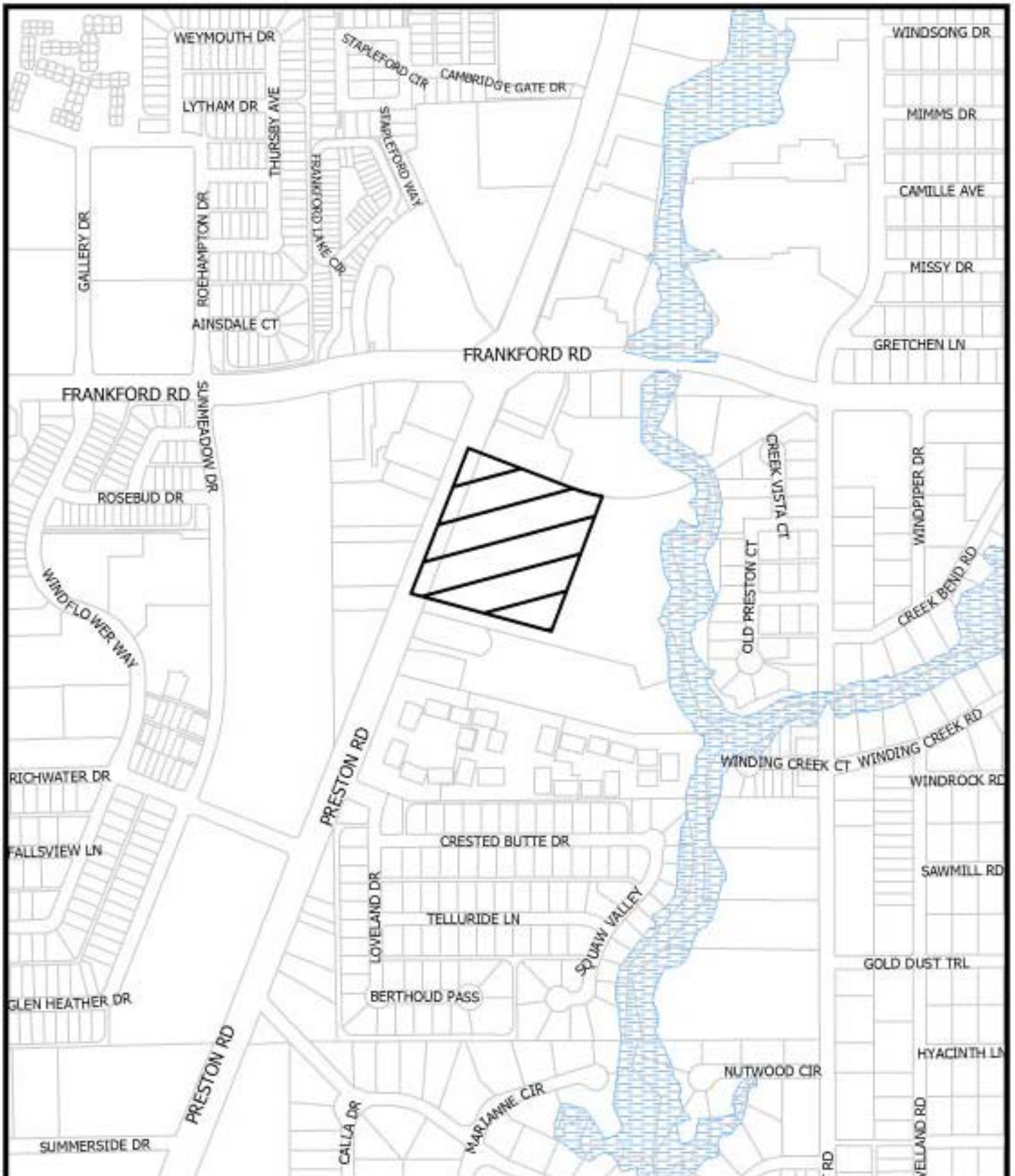

1:6,000

# VICINITY MAP

Case no: Z156-175

Date: 1/26/2016

**FILE NUMBER:** Z156-175(OTH)

**DATE FILED:** December 28, 2015

**LOCATION:** East side of Preston Road, South of Frankford Road

**COUNCIL DISTRICT:** 12

**MAPSCO:** 5-G

**SIZE OF REQUEST:** Approx. 6.29 acres

**CENSUS TRACT:** 317.08

**APPLICANT/OWNER:** Caddo Preston Plaza LLC

**REPRESENTATIVE:** Rob Baldwin

**REQUEST:** An application for a GO(A) General Office District on property zoned an MO-2 Mid-range Office District.

**SUMMARY:** The applicant is requesting the zoning change to make the existing retail uses conforming uses. The site is currently developed with a ten-story building and a parking garage. The property is utilized for retail and office uses. On April 8, 2015, the City Council approved an MO-2 Mid-Range Office District with volunteered deed restrictions on the property which was previously zoned a CR Community Retail District (Z134-332). (The application was originally submitted for an MU-3 Mixed Use District with volunteered deed restrictions.) Some of the existing uses were inadvertently made nonconforming by rezoning the property to MO-2 because some of the uses that were permitted by right in the CR District are only allowed as limited used in the MO-2 District. The applicant is not proposing or requesting any changes to the existing deed restrictions.

**CPC RECOMMENDATION:** Approval

**STAFF RECOMMENDATION:** Approval

Z156-175(OTH)

**Partners and Principles**  
17950 Preston Road

Caddo Preston Plaza LLC

Caddo Preston Plaza GP, LLC

Dustin Schillin, managing partner  
Tim Slaughter, managing partner  
Justin Engler, managing partner



<u>32</u>	Property Owners Notified (41 parcels)
<u>2</u>	Replies in Favor (2 parcels)
<u>0</u>	Replies in Opposition (0 parcels)
<u>400'</u>	Area of Notification
<u>4/13/2016</u>	Date

**Z156-175**

**CC**



1:3,600

04/12/2016

## *Reply List of Property Owners*

*Z156-175*

*32 Property Owners Notified*

*2 Property Owners in Favor*

*0 Property Owners Opposed*

<i>Reply</i>	<i>Label #</i>	<i>Address</i>	<i>Owner</i>
	1	17950 PRESTON RD	CADDO PRESTON PLAZA LLC
	2	17772 PRESTON RD	17772 PRESTON LLC
	3	17878 PRESTON RD	WESTDALE POLO CLUB LTD
O	4	17717 PRESTON RD	SUMMER VILLAS APARTMENTS LLC
	5	PRESTON RD	G O C ASSOCIATION INC
	6	17742 PRESTON RD	NIDO PROPERTIES LLC
	7	17744 PRESTON RD	BLACK THOMAS E JR &
	8	17754 PRESTON RD	EZ ESTATES LLC
	9	17770 PRESTON RD	EVC PROPERTIES LLC
	10	18081 PRESTON RD	CCMR 18 LLC
	11	18008 PRESTON RD	OOZI INVESTMENTS INC
	12	17858 PRESTON RD	GVD COMMERCIAL PROPERTIES INC
	13	17848 PRESTON RD	GOOD TAC REMAINDER IV LLC
	14	17854 PRESTON RD	ESS PRISA II TX LP
	15	17981 PRESTON RD	WENDY'S INTERNATIONAL INC
	16	17879 PRESTON RD	RETAIL BUILDINGS INC
O	17	17977 PRESTON RD	DF2 LLC
	18	17885 PRESTON RD	J WILSON PROPERTIES LLC
	19	6150 FRANKFORD RD	FONBERG REAL ESTATE INVESTMENTS LTD
	20	6330 FRANKFORD RD	ROYSS LLC
	21	6340 FRANKFORD RD	KWIK SUDS CAR WASH LLC
	22	6350 FRANKFORD RD	JEON'S MANAGEMENT LLC
	23	18000 PRESTON RD	BEHNAM ORIENTAL RUG CORP
	24	18004 PRESTON RD	SHURGARD TEXAS LP3
	25	6110 FRANKFORD RD	FONBERG REAL ESTATE INVESTMENTS LTD
	26	17899 PRESTON RD	SAAD BASEL

04/12/2016

<i>Reply</i>	<i>Label #</i>	<i>Address</i>	<i>Owner</i>
	27	17931 PRESTON RD	ZINCO ENTERPRISES INC
	28	18101 PRESTON RD	PRESTON EXCHANGE PROPERTY LLC
	29	STATE HWY 289 (PRESTON RD)	STATE OF TEXAS
	30	FRANKFORD RD	STATE OF TEXAS
	31		STATE OF TEXAS
	32	17921 PRESTON RD	ALLAHYARI MANSOUR &

**KEY FOCUS AREA:** E-Gov  
**AGENDA DATE:** April 27, 2016  
**COUNCIL DISTRICT(S):** All  
**DEPARTMENT:** Mayor and City Council  
**CMO:** A. C. Gonzalez, 670-3297  
**MAPSCO:** N/A

---

**SUBJECT**

A resolution appointing Christopher D. Bowers, as Interim City Attorney for the City of Dallas, effective at the close of business on April 29, 2016, to serve until the City Council selects and appoints a permanent City Attorney - Financing: No cost consideration to the City

**BACKGROUND**

City Attorney Warren Ernst submitted his resignation on November 10, 2015, effective at the close of business on April 29, 2016.

**PRIOR ACTION/REVIEW (COUNCIL, BOARDS, COMMISSIONS)**

Council discussed in closed session on April 13, 2016.

**FISCAL INFORMATION**

No cost consideration to the City.

April 27, 2016

**WHEREAS**, Warren Ernst has submitted his resignation as City Attorney and as head of the legal department, effective at the close of business on April 29, 2016; and

**WHEREAS**, the City Council has determined that it is necessary to appoint an Interim City Attorney during the time it takes to select a permanent City Attorney; **Now, Therefore**,

**BE IT RESOLVED BY THE CITY COUNCIL OF THE CITY OF DALLAS:**

**Section 1.** That Christopher D. Bowers is hereby appointed Interim City Attorney, effective at the close of business on April 29, 2016, to serve until the City Council selects and appoints a permanent City Attorney. During this temporary appointment period, Christopher D. Bowers shall have the full powers and duties of the City Attorney as provided in the City Charter and ordinances, and shall be paid his annual base salary, plus an additional interim assignment pay in accordance with the City's Compensation Policies, while serving in this capacity.

**Section 2.** That this resolution shall take effect immediately from and after its passage in accordance with the provisions of the Charter of the City of Dallas, and it is accordingly so resolved.



**KEY FOCUS AREA:** E-Gov  
**AGENDA DATE:** April 27, 2016  
**COUNCIL DISTRICT(S):** N/A  
**DEPARTMENT:** Office of Financial Services  
**CMO:** Jeanne Chipperfield, 670-7804  
**MAPSCO:** N/A

---

**SUBJECT**

A resolution ordering Oncor Electric Delivery Company, LLC to show cause regarding the reasonableness of its existing Transmission and Distribution rates within the City of Dallas - Financing: No cost consideration to the City

**BACKGROUND**

This item was placed on the addendum and is moved forward by Council direction.

The City is a regulatory authority under the Public Utility Regulatory Act (PURA) and has original jurisdiction over the rates of Oncor Electric Delivery Company, LLC (Oncor). Pursuant to section 33.021, 36.003 and 36.151 of PURA the City may on its own motion or on a complaint by an affected person, initiate a proceeding to determine whether the existing rates of a public utility are unreasonable or in any way in violation of any provision of law. Upon such a finding of unreasonableness, the City may determine just and reasonable rates.

The City has reason to believe that Oncor is over earning and that its rates are excessive. The Executive Committee of the Steering Committee of Cities Served by Oncor, of which Dallas is a member, is recommending that all member cities initiate show cause proceedings against Oncor. The Steering Committee has agreed to retain consultants at their expense to assist the City in its review of Oncor's rates; however, the City reserves its right to seek reimbursement from Oncor.

**PRIOR ACTION/REVIEW (Council, Boards, Commissions)**

On April 20, 2016 this item was briefed to City Council.

**FISCAL INFORMATION**

No cost consideration to the City.

April 27, 2016

**WHEREAS**, the City of Dallas is a regulatory authority within the meaning of the Public Utility Regulatory Act (PURA), which also vests the City as a regulatory authority with original jurisdiction over the rates of Oncor Electric Delivery Company, LLC (Oncor) to determine if such rates are just and reasonable; and

**WHEREAS**, Sections 33.021, 36.003 and 36.151 of PURA empower a regulatory authority, on its own motion or on a complaint by any affected person, to determine whether the existing rates of any public utility for any service are unreasonable or in any way in violation of any provision of law, and upon such determination, to determine the just and reasonable rates; and

**WHEREAS**, the City of Dallas has reason to believe that Oncor is over earning and that its rates exceed those which are just and reasonable; and

**WHEREAS**, the City of Dallas is a member of the Steering Committee of Cities Served By Oncor; and

**WHEREAS**, the Executive Committee of the Steering Committee of Cities Served by Oncor has recommended that cities pass a resolution that requires Oncor to show cause why its transmission and distribution rates should not be reduced; and

**WHEREAS**, the City of Dallas, and the City Council of the City of Dallas desires, on its own motion, to exercise its authority under Sections 33.021, 36.003 and 36.151 of PURA; and

**WHEREAS**, a procedural schedule should be established for the filing of certain information by Oncor, procedures to be followed to obtain and review information from Oncor, the filing of an analysis of such information by the City, the filing of rebuttal information from Oncor, and a public hearing at which time the City shall make a determination whether the existing rates of Oncor are unreasonable or unjust, including whether they are in any way in violation of any provision of law, and if such rates should be revised and just and reasonable rates determined for Oncor.

April 27, 2016

**Now, Therefore,**

**BE IT RESOLVED BY THE CITY COUNCIL OF THE CITY OF DALLAS:**

**SECTION 1.** That this resolution constitutes notice of the City's intent to proceed with an inquiry into the transmission and distribution rates charged by Oncor. On or before September 1, 2016, Oncor shall file with the City of Dallas, information that demonstrates good cause for showing that Oncor's transmission and distribution rates should not be reduced. Specifically, Oncor shall file with the City of Dallas information for the test year beginning January 1, 2015 and ending December 31, 2015, regarding Oncor's cost of service elements, including, but not limited to the elements detailed by the Public Utility Commission as necessary for the filing of a Statement of Intent to Change Rates. The test year may be updated for more current data and shall be adjusted for known and measurable changes.

**SECTION 2.** That the City's designated representatives shall have the right to obtain additional information from Oncor through the filing of written requests for information, to each of which Oncor shall respond in writing within fifteen (15) calendar days from the receipt of each such request for information.

**SECTION 3.** That the City's designated representative shall file his or her analysis of Oncor's filing and information on or before October 13, 2016. Such analysis may include or refer to any analysis or report by any consultant retained by the City in connection with work necessitated by this resolution.

**SECTION 4.** That Oncor shall file any rebuttal to the analysis of City's representative on or before November 10, 2016. With its rebuttal, Oncor may present whatever additional information it desires to defend its current rates.

**SECTION 5.** That the City Council will be briefed on Oncor's rate filing at its regular scheduled meeting on December 7, 2016. After the briefing by staff, a representative of Oncor and a representative of the City of Dallas' consultants will each be allowed to address the City Council and summarize previously filed reports for no more than 15 minutes.

**SECTION 6.** That a public hearing shall be conducted by the City Council for the City of Dallas on December 14, 2016, during the regular council meeting scheduled to commence no earlier than 1 p.m. Based upon such hearing, the briefing of staff, and the consultants' findings, a determination of the reasonableness of the existing rates of Oncor shall be made by the City Council and, if necessary, just and reasonable rates shall be determined to be thereafter observed and enforced for all services of Oncor within the City of Dallas, Texas.

April 27, 2016

**SECTION 7.** That the City Council may, from time to time, amend this procedural schedule and enter additional orders as may be necessary in the public interest and to enforce the provisions hereof.

**SECTION 8.** That subject to the right to terminate employment at any time, the City of Dallas hereby ratifies the Steering Committee's selection of Geoffrey Gay with the law firm of Lloyd, Gosselink, Blevins, Rochelle & Townsend as legal counsel to assist the City of Dallas in its ratemaking and to prosecute any appeals to the Texas Public Utility Commission or court. The Executive Committee of the Steering Committee of Cities Served by Oncor shall retain appropriate consultants to prepare a report and make rate recommendations.

**SECTION 9.** That fees and expenses of attorneys and consultants assisting the City in the Steering Committee's review of the reasonableness of Oncor's rates will be processed through the Steering Committee but the City reserves the right to seek reimbursement from Oncor pursuant to the PURA Section 33.023.

**SECTION 10.** That it is hereby officially found and determined that the meeting at which this resolution was passed was open to the public as required by law, and that public notice of the time, place, and purpose of said meeting was given all as required by Section 551.041, Texas Government Code.

**SECTION 11.** That this resolution shall take effect immediately from and after its passage in accordance with the provisions of the Charter of the City of Dallas, and it is accordingly so resolved.

APPROVED AS TO FORM:  
WARREN M. S. ERNST  
City Attorney

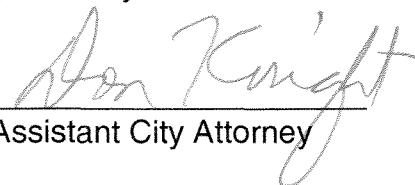
By   
Assistant City Attorney

**KEY FOCUS AREA:** Economic Vibrancy

**AGENDA DATE:** April 27, 2016

**COUNCIL DISTRICT(S):** 2, 3, 4, 5, 6, 7, 8

**DEPARTMENT:** Sustainable Development and Construction

**CMO:** Ryan S. Evans, 671-9837

**MAPSCO:** 34S 36A 42U 43F K 44J 45W Z 46L M P Q R T U V W X Y Z  
 47J S 48T 54V Z 55B F H K L M P S W Z 56B C D T V W X  
 57M 62A 63D 64B Q 65A F H L 66K S 68A 69A-F L P

**SUBJECT**

Authorize the quitclaim of 96 properties acquired by the taxing authorities from the Tax Foreclosure Sheriff's Sale to the highest bidders; and authorize the execution of release of liens for any non-tax liens that may have been filed by the City and were included in the foreclosure judgment (list attached) - Revenue: \$585,974

**BACKGROUND**

This item authorizes the quitclaim of 96 properties that were foreclosed by the Sheriff's Department for unpaid taxes pursuant to judgments or seizure warrants from a District Court and the release of liens for any non-tax liens that may have been filed by the City and were included in the foreclosure judgment. These properties are being sold to the highest bidders and will return to the tax rolls upon conveyance.

Successful bidders are required to sign a certification stating that they are not purchasing these properties on behalf of the foreclosed owners and that they have no debts owed to the City, no pending code violations, and are not chronic code violators.

All properties were reviewed by the Housing Department for infill housing and were not desired for that program.

**PRIOR ACTION/REVIEW (COUNCIL, BOARDS, COMMISSIONS)**

Information about this item will be provided to the Economic Development Committee on April 18, 2016.

**FISCAL INFORMATION**

Revenue: \$585,973.04

## **OWNERS**

### **Anthony Boyd IRA LLC**

Anthony Boyd, Managing Member

### **Axxan Green, Inc.**

Mariza Ortega, President

### **Citywide Development & Construction, LLC**

Gardner Brewer, Managing Member

### **County Land and Water LLC Series COM1**

Wayne Prokay, Managing Member

### **DFW Projects LLC**

Johnny Aguinaga, Managing Member

### **Glo-Nite, Inc.**

Butch Benavides, President

### **Homex Change LLC DBA Nomax Homex Change**

Xochitl Trejo, Managing Member

### **JDS-Q Services, LLC**

LaQuonda Brewer, Managing Member

### **Nextlots Now L.L.C.**

Lee J. Schmitt, Managing Member

### **Tri-Capital Equities LLC**

Jordan DSilva, Managing Member

Alfonso Ruiz

Alma Mireya Reyes Barbosa

Alonso Olmos

Angelica Hernandez

Aubrey Quarles

Benito Mojica

Carlos Guzman

**OWNERS** (Continued)

Carmen Olguin

Christina Martinez

Clifford Johnson Jr.

Cristal Benitez

Daporscha Kelley

Devan Earle

Doric Earle

Edmond Chiu

Eric Arevalo

Esteban Melgarejo Castillo

Francisco Mujica

Genaro B. Fierro

Guadalupe Martinez

Jonathan Bender

Jose Saragoza

Kelly Martinez

Kimiaki Itamura

Lonnie Barnes

Luis Mendez

Maria Schneider

Maria Estrada

Mason Sneed Hensley

Maxine Hightower

**OWNERS** (Continued)

Megan E. Knauss

M.W. Resnick

Nereida Vasquez

Oscar Garcia

Raquel Rollins

Rolando Cobos

Samuel Demissew

Shaymah Mahdi

Sherri M. Title

Stephani A. Kyle

Tena Ny

Tonya Watson

W. Justin Title

**MAP**

Attached



**TAX FORECLOSED AND SEIZURE WARRANT PROPERTY RESALES  
PROPERTY LIST**

ITEM #	STREET ADDRESS	VAC/IMP	COUNCIL DISTRICT	ZONING	PARCEL SIZE	STRUCKOFF AMOUNT	# BIDS	MINIMUM BID	HIGHEST BID AMOUNT	DCAD	HIGHEST BIDDER
1	1221 10TH	V	4	PD-388	.0663	\$4,340.00	4	\$1,000.00	\$1,750.00	\$4,340.00	GUADALUPE MARTINEZ
2	1131 11TH ST	V	4	PD-388	.2630	\$14,517.00	2	\$1,000.00	\$1,275.00	\$17,190.00	NEXTLOTS NOW L.L.C.
3	1535 ADELAIDE	V	4	R-7.5(A)	.1692	\$6,000.00	2	\$1,000.00	\$2,275.00	\$6,000.00	NEXTLOTS NOW L.L.C.
4	3018 ARIZONA	V	4	R-7.5(A)	.1753	\$15,000.00	4	\$1,000.00	\$12,500.00	\$15,000.00	NEREIDA VASQUEZ
5	5511 ARLINGTON PARK	V	2	MU-2	.0649	\$37,927.00	8	\$250.00	\$2,483.00	\$1,250.00	MASON SNEED HENSLEY
6	1619 AVENUE B	V	4	PD-5(A)	.0734	\$5,000.00	2	\$1,000.00	\$2,895.00	\$5,000.00	NEXTLOTS NOW L.L.C.
7	419 AVENUE L	V	4	D(A)	.1273	\$8,427.00	1	\$1,000.00	\$1,451.00	\$9,500.00	ROLANDO COBOS
8	3300 BEAUCHAMP	V	4	R-5(A)	.1730	\$11,500.00	1	\$1,000.00	\$1,285.00	\$11,500.00	NEXTLOTS NOW L.L.C.
9	1822 BICKERS	V	6	R-5(A)	.1214	\$2,195.00	14	\$1,000.00	\$11,666.96	\$8,470.00	ANGELICA HERNANDEZ
10	3844 BLUE RIDGE	V	3	R-10(A)	5.7140	\$124,450.00	5	\$25,000.00	\$50,000.00	\$124,450.00	SHAYMAH MAHDI
11	6425 C F HAWN	V	5	TH-3(A)	.4821	\$15,400.00	6	\$4,000.00	\$21,386.00	\$39,670.00	AXXAN GREEN, INC.
12	1618 CALDWELL	V	7	D(A)	.1179	\$5,140.00	3	\$1,000.00	\$3,000.99	\$5,140.00	ALMA MIREYA REYES BARBOSA
13	1614 CALDWELL	V	7	D(A)	.1119	\$4,880.00	3	\$1,000.00	\$3,000.99	\$4,880.00	ALMA MIREYA REYES BARBOSA
14	4215 CANAL	V	7	PD-595	.1426	\$1,113.00	2	\$1,000.00	\$2,200.00	\$5,000.00	KIMIAMI ITAMURA
15	4328 CANAL	V	7	PD-595	.1414	\$1,484.00	2	\$1,000.00	\$2,052.00	\$5,000.00	CLIFFORD JOHNSON JR.
16	3814 CARL	V	7	PD-595	.1458	\$1,295.00	4	\$1,000.00	\$2,795.00	\$5,000.00	NEXTLOTS NOW L.L.C.
17	2437 CEDAR CREST	V	4	CR	.7174	\$18,850.00	2	\$3,000.00	\$5,100.00	\$31,250.00	AUBREY QUARLES
18	1427 CEDAR OAKS	V	4	R-7.5(A)	.1813	\$13,000.00	4	\$1,000.00	\$29,999.00	\$31,250.00	CITYWIDE DEVELOPMENT & CONSTRUCTION, LLC
19	1200 CLAUDE	I	4	R-5(A)	.1615	\$11,500.00	11	\$10,000.00	\$35,000.00	\$34,470.00	ERIC AREVALO
20	1229 CLAUDE	V	4	R-5(A)	.1714	\$34,760.00	4	\$1,000.00	\$3,100.00	\$6,229.86	ALONSO OLMOS
21	4422 COLONIAL	V	7	PD-595	.1338	\$1,542.00	2	\$1,000.00	\$1,400.00	\$5,250.00	W. JUSTIN TITTLE AND SHERRI M. TITTLE

**TAX FORECLOSED AND SEIZURE WARRANT PROPERTY RESALES  
PROPERTY LIST**

ITEM #	STREET ADDRESS	VAC/IMP	COUNCIL DISTRICT	ZONING	PARCEL SIZE	STRUCKOFF AMOUNT	# BIDS	MINIMUM BID	HIGHEST BID AMOUNT	DCAD	HIGHEST BIDDER
22	3815 COLONIAL	V	7	PD-595	.1400	\$2,558.00	2	\$1,000.00	\$1,385.00	\$5,490.00	MARIA SCHNEIDER, DEVAN EARLE, DORIC EARLE, AND M.W. RESNICK
23	1100 COMAL	V	4	PD-571	.0479	\$7,000.00	7	- \$1,000.00	\$2,765.02	\$7,000.00	MEGAN E. KNAUSS AND STEPHANI A. KYLE
24	1102 COMAL	V	4	PD-571	.0214	\$7,000.00	7	\$1,000.00	\$2,550.00	\$7,000.00	CRISTAL BENITEZ
25	3910 COPELAND	V	7	PD 595	.1458	\$1,518.00	5	\$250.00	\$2,100.00	\$5,000.00	KIMIYAKI ITAMURA
26	4334 COPELAND	V	7	PD-595	.1017	\$30,463.00	2	\$250.00	\$300.00	\$37,800.00	CHRISTINA MARTINEZ AND KELLY MARTINEZ
27	3819 COPELAND	V	7	PD-595	.1432	\$1,848.00	2	\$1,000.00	\$2,050.00	\$5,000.00	KIMIYAKI ITAMURA
28	4015 COPELAND	V	7	PD-595	.1204	\$14,489.00	3	\$250.00	\$500.00	\$3,750.00	TENA NY
29	2810 DATHE	V	7	PD-595	.1228	\$2,881.00	2	\$1,000.00	\$3,100.00	\$5,000.00	GENARO B. FIERRO
30	2415 DATHE	I	7	PD-595	.1215	\$23,370.00	8	\$3,000.00	\$15,050.00	\$23,370.00	JOSE SARAGOZA
31	1410 DENLEY	V	4	R-7.5(A)	1.4420	\$23,000.00	3	\$3,000.00	\$5,800.00	\$23,000.00	BENITO MOJICA
32	1732 DENLEY	V	4	CR	.2164	\$1,310.00	2	\$1,000.00	\$3,075.00	\$13,000.00	NEXTLOTS NOW L.L.C.
33	1429 DICEMAN	V	4	R-7.5(A)	.3309	\$9,500.00	4	\$1,000.00	\$2,200.00	\$9,500.00	BENITO MOJICA
34	2323 ECHO LAKE	V	8	R-7.5(A)	.3389	\$12,000.00	5	\$1,000.00	\$3,725.00	\$12,000.00	NEXTLOTS NOW L.L.C.
35	711 ELSTON	V	3	R-7.5(A)	.2559	\$12,000.00	1	\$500.00	\$2,900.00	\$12,000.00	JDS-Q SERVICES, LLC
36	1306 EMILY	V	4	R-7.5(A)	.2466	\$7243.00	2	\$500.00	\$600.00	\$10,000.00	ALFONSO RUIZ
37	1310 EMILY	V	4	R-7.5(A)	.2071	\$7,065.00	2	\$500.00	\$600.00	\$10,000.00	ALFONSO RUIZ
38	1314 EMILY	V	4	R-7.5(A)	.1949	\$7,211.00	2	\$500.00	\$600.00	\$10,000.00	ALFONSO RUIZ
39	5608 FANNIE	V	6	R-5(A)	.0321	\$4,800.00	4	\$500.00	\$3,280.00	\$2,400.00	DFW PROJECTS, LLC
40	1302 FOLEY	V	2	R-5(A)	.0594	\$2,590.00	1	\$500.00	\$605.00	\$2,590.00	NEXTLOTS NOW L.L.C.
41	3407 FORNEY	V	2	CS	.0797	\$4,350.00	2	\$500.00	\$3,150.00	\$4,350.00	NEXTLOTS NOW L.L.C.
42	4314 FRANK	V	7	PD-595	.1451	\$1,136.00	4	\$1,000.00	\$3,500.00	\$5,000.00	MAXINE HIGHTOWER

**TAX FORECLOSED AND SEIZURE WARRANT PROPERTY RESALES  
PROPERTY LIST**

ITEM #	STREET ADDRESS	VAC/IMP	COUNCIL DISTRICT	ZONING	PARCEL SIZE	STRUCKOFF AMOUNT	# BIDS	MINIMUM BID	HIGHEST BID AMOUNT	DCAD	HIGHEST BIDDER
43	4326 FRANK	V	7	PD-595	.1416	\$1,555.00	2	\$1,000.00	\$1,108.00	\$5,000.00	MARIA SCHNEIDER, DEVAN EARLE, DORIC EARLE, AND M.W. RESNICK
44	4007 FUREY	V	6	R-5(A)	.1567	\$12,000.00	10	\$1,000.00	\$10,200.00	\$12,000.00	DFW PROJECTS, LLC
45	4711 GARRISON	V	4	R-7.5(A)	.0758	\$3,310.00	1	\$500.00	\$507.00	\$3,310.00	ANTHONY BOYD IRA LLC
46	1306 GLIDDEN	V	4	R-5(A)	.0941	\$1,426.00	1	\$250.00	\$355.00	\$9,780.00	LONNIE BARNES
47	2721 GOULD	V	7	PD-595	.1987	\$6,243.00	5	\$1,000.00	\$5,400.02	\$18,380.00	MEGAN E. KNAUSS AND STEPHANI A. KYLE
48	2821 GOULD	V	7	PD-595	.1469	\$9,600.00	2	\$1,000.00	\$3,571.00	\$16,000.00	DEVAN EARLE
49	4226 HAMILTON	V	7	PD-595	.1461	\$1,404.00	1	\$1,000.00	\$2,250.00	\$5,000.00	KIMIAMI ITAMURA
50	2427 HARDING	I	7	PD-595	.1519	\$22,030.00	4	\$3,500.00	\$15,000.00	\$22,030.00	ESTEBAN MELGAREJO CASTILLO
51	4511 HEDGDON	V	4	R-10(A)	.9226	\$12,725.00	2	\$2,000.00	\$6,875.00	\$24,000.00	NEXTLOTS NOW L.L.C.
52	1410 HENDRICKS	V	4	R-5(A)	.1652	\$7,472.00	4	\$1,000.00	\$2,501.00	\$11,500.00	EDMOND CHIU
53	1311 HENDRICKS	V	4	R-5(A)	.1698	\$11,500.00	3	\$1,000.00	\$2,435.00	\$11,500.00	NEXTLOTS NOW L.L.C.
54	2912 HOLMES	V	7	PD-595	.2066	\$12,500.00	2	\$1,000.00	\$4,600.00	\$22,500.00	COUNTY LAND AND WATER LLC SERIES COM1
55	2630 IDAHO	V	4	R-7.5(A)	.1723	\$11,000.00	3	\$1,000.00	\$3,125.00	\$11,000.00	NEXTLOTS NOW L.L.C.
56	4114 JAMAICA	V	7	PD-595	.1607	\$1,294.00	3	\$1,000.00	\$3,786.00	\$8,760.00	GLO-NITE, INC.
57	3623 KENILWORTH	V	7	PD-595	.1451	\$2,137.00	1	\$1,000.00	\$1,188.00	\$3,160.00	MARIA SCHNEIDER, DEVAN EARLE, DORIC EARLE, AND M.W. RESNICK
58	3504 KEYRIDGE	V	8	R-7.5(A)	.2188	\$1,479.00	2	\$1,000.00	\$6,865.00	\$12,000.00	NEXTLOTS NOW L.L.C.
59	4947 KILDARE	V	3	R-7.5(A)	.2954	\$22,380.00	2	\$1,000.00	\$1,875.00	\$6,000.00	NEXTLOTS NOW L.L.C.
60	2727 LAWRENCE	I	7	PD-595	.1613	\$17,490.00	2	\$6,000.00	\$10,007.00	\$17,490.00	TRI-CAPITAL EQUITIES LLC
61	2736 LEBROCK	V	8	R-5(A)	.2915	\$8,000.00	1	\$500.00	\$550.00	\$8,000.00	RAQUEL ROLLINS
62	3744 LEGENDARY	V	4	MF-2(A)	6.6187	\$708,970.00	3	\$37,500.00	\$53,520.00	\$360,390.00	TONYA WATSON

**TAX FORECLOSED AND SEIZURE WARRANT PROPERTY RESALES  
PROPERTY LIST**

ITEM #	STREET ADDRESS	VAC/IMP	COUNCIL DISTRICT	ZONING	PARCEL SIZE	STRUCKOFF AMOUNT	# BIDS	MINIMUM BID	HIGHEST BID AMOUNT	DCAD	HIGHEST BIDDER
63	2524 MARBURG	V	7	PD 595	.2200	\$1,624.00	3	\$250.00	\$500.00	\$6,000.00	W. JUSTIN TITTE AND SHERRI M. TITTE
64	2231 MARBURG	V	7	PD-595	.1729	\$6,000.00	2	\$500.00	\$1,000.00	\$6,000.00	W. JUSTIN TITTE AND SHERRI M. TITTE
65	1212 MARFA	V	4	R-7.5(A)	.2012	\$10,000.00	1	\$1,000.00	\$1,525.00	\$10,000.00	NEXTLOTS NOW L.L.C.
66	2639 MARFA	V	4	R-7.5(A)	.2100	\$19,429.00	1	\$500.00	\$1,375.00	\$13,000.00	NEXTLOTS NOW L.L.C.
67	5703 MARGEWOOD	I	3	R-7.5(A)	.2615	\$23,119.00	8	\$7,000.00	\$30,100.00	\$45,060.00	CRISTAL BENITEZ AND OSCAR GARCIA
68	18 MARGEWOOD	V	3	R-7.5(A)	.5657	\$16,083.00	5	\$2,000.00	\$10,050.00	\$21,200.00	LUIS MENDEZ AND CARLOS GUZMAN
69	2911 MARSALIS	V	4	R-7.5(A)	.1860	\$13,500.00	7	\$1,000.00	\$14,500.00	\$13,500.00	NEREIDA VASQUEZ
70	2726 MEADOW	V	7	PD-595	.1320	\$4,911.00	5	\$500.00	\$888.00	\$11,500.00	JONATHAN BENDER
71	4223 METROPOLITAN	V	7	PD-595	.1494	\$1,752.00	3	\$1,000.00	\$1,855.00	\$5,000.00	DAPORSCHA KELLEY
72	3321 MORRIS	I	6	R-5(A)	.1668	\$48,610.00	8	\$7,000.00	\$20,563.00	\$48,610.00	HOMEX CHANGE LLC DBA NOMAS HOMEX CHANGE
73	2732 PARNELL	V	7	PD-595	.1606	\$10,500.00	2	\$1,000.00	\$1,799.00	\$17,500.00	DEVAN EARLE
74	4337 PENELOPE	V	7	PD-595	.1483	\$2,287.00	2	\$1,000.00	\$1,207.00	\$5,000.00	DEVAN EARLE
75	1308 PENNSYLVANIA	V	7	PD-595	.1802	\$1,649.00	4	\$1,000.00	\$2,855.00	\$19,630.00	DAPORSCHA KELLEY
76	3902 PINE	V	7	PD-595	.1202	\$1,640.00	2	\$1,000.00	\$1,456.00	\$5,000.00	FRANCISCO MUJICA
77	11700 RAVENVIEW	V	8	R-10(A)	.9270	\$5,560.00	1	\$1,000.00	\$1,500.00	\$5,560.00	OSCAR GARCIA
78	3231 REED	V	7	PD-595	.1721	\$2,401.00	2	\$1,000.00	\$1,501.00	\$6,000.00	FRANCISCO MUJICA
79	3327 REED	V	7	PD-595	.1721	\$1,539.00	3	\$1,000.00	\$1,501.00	\$6,000.00	FRANCISCO MUJICA
80	3923 ROBERTS	I	7	PD-595	.1126	\$16,146.00	1	\$5,000.00	\$5,777.00	\$13,550.00	TRI-CAPITAL EQUITIES LLC
81	7331 SCYENE	V	5	R-7.5(A)	.2937	\$16,000.00	3	\$2,000.00	\$6,400.00	\$16,000.00	BENITO MOJICA
82	8906 SEDGEMOOR	V	8	R-7.5(A)	.5166	\$9,843.00	11	\$2,000.00	\$25,399.00	\$16,880.00	CITYWIDE DEVELOPMENT & CONSTRUCTION, LLC
83	2624 SEEVERS	V	4	R-7.5(A)	.1699	\$14,000.00	8	\$500.00	\$14,757.00	\$14,000.00	NEREIDA VASQUEZ
84	1903 SMOKE TREE	V	8	PD-258	.5252	\$15,000.00	6	\$1,000.00	\$4,200.00	\$15,000.00	CARMEN OLGUIN

**TAX FORECLOSED AND SEIZURE WARRANT PROPERTY RESALES  
PROPERTY LIST**

ITEM #	STREET ADDRESS	VAC/IMP	COUNCIL DISTRICT	ZONING	PARCEL SIZE	STRUCKOFF AMOUNT	# BIDS	MINIMUM BID	HIGHEST BID AMOUNT	DCAD	HIGHEST BIDDER
85	1732 SMOKE TREE	V	8	PD-258	.1749	\$9,000.00	1	\$1,000.00	\$1,875.00	\$9,000.00	NEXTLOTS NOW L.L.C.
86	2714 SOUTHLAND	V	7	PD-595	.1543	\$1,800.00	2	\$250.00	\$901.10	\$6,000.00	SAMUEL DEMISSEW
87	2374 SOUTHWOOD	V	4	R-7.5(A)	.2854	\$11,097.00	3	\$2,000.00	\$5,579.00	\$20,700.00	DEVAN EARLE
88	4603 SPRING GARDEN	V	7	PD 595	.1147	\$2,254.00	2	\$1,000.00	\$2,005.00	\$6,000.00	TONYA WATSON
89	2728 SWANSON	V	7	PD-595	.1152	\$1,879.00	2	\$1,000.00	\$1,605.00	\$5,000.00	TONYA WATSON
90	524 TAMA	V	4	R-5(A)	.0700	\$7,409.00	2	\$ 500.00	\$1,000.00	\$7,480.00	MARIA ESTRADA
91	1306 VALLEY	V	4	R-5(A)	.0820	\$8,630.00	3	\$1,000.00	\$2,375.00	\$8,630.00	NEXTLOTS NOW L.L.C.
92	1314 VALLEY	V	4	R-5(A)	.0826	\$8,630.00	3	\$500.00	\$2,575.00	\$8,630.00	NEXTLOTS NOW L.L.C.
93	4319 WILLOW SPRINGS	I	7	PD-595	.1144	\$22,608.00	6	\$7,000.00	\$22,666.96	\$46,320.00	ANGELICA HERNANDEZ
94	709 WOODBINE	V	4	R-5(A)	.1492	\$1,626.00	4	\$250.00	\$1,005.00	\$3,600.00	TONYA WATSON
95	3807 YORK	V	7	PD 595	.1311	\$1,446.00	4	\$250.00	\$755.00	\$2,860.00	TONYA WATSON
96	3531 YORK	V	7	PD 595	.1492	\$1,621.00	5	\$250.00	\$755.00	\$3,250.00	TONYA WATSON

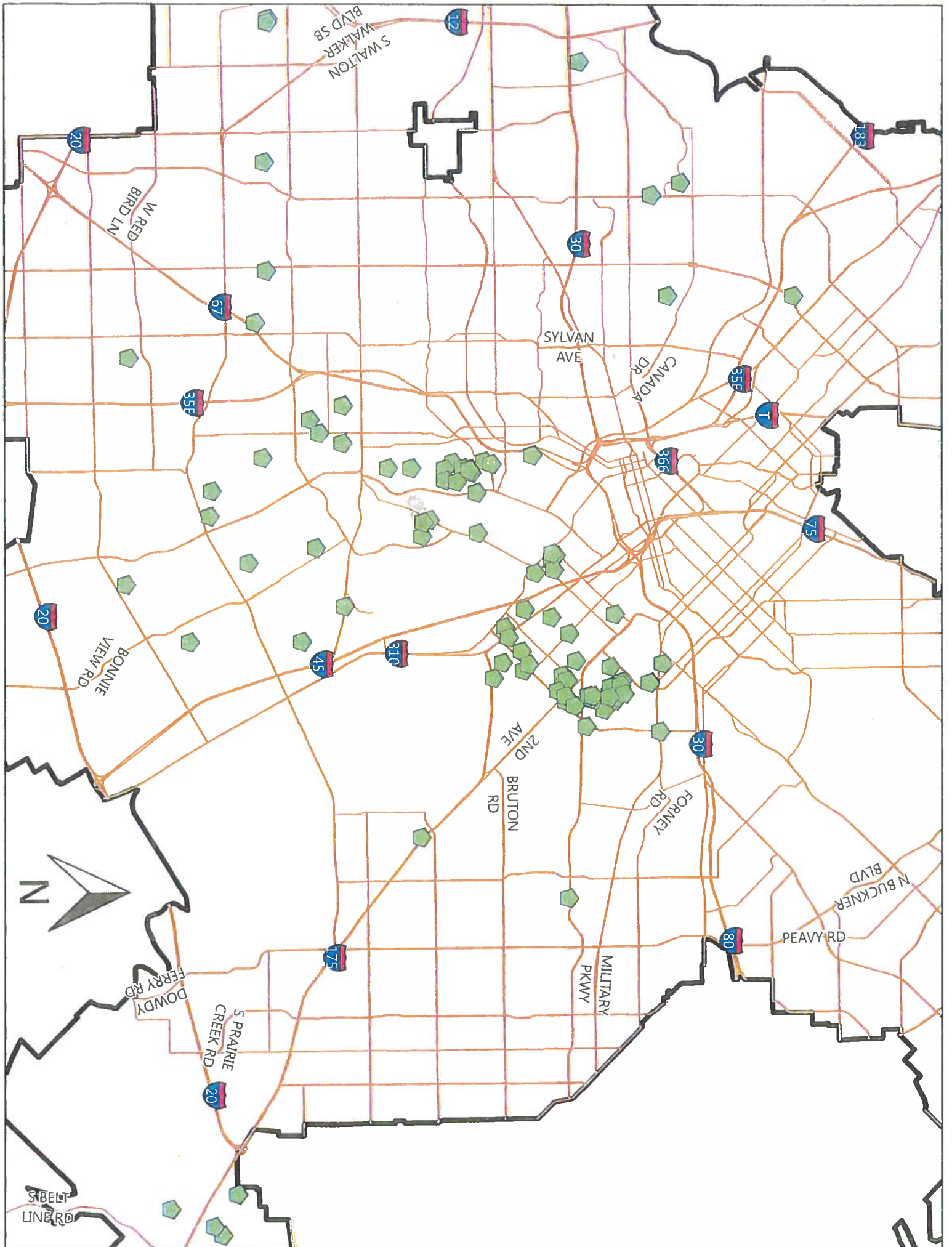

April 27, 2016

**WHEREAS**, the City of Dallas (“City”), the State of Texas (“State”), the County of Dallas, (“County”), and/or Dallas Independent School District (“DISD”) acquired Sheriff Deeds to properties (“Properties”) at a sheriff tax sale (“the First Sale”) authorized by a Judicial Foreclosure (“Judgment”) in a District Court in Dallas County, Texas. The Sheriff’s Deeds were recorded in the real property records of Dallas County, Texas as described on “Exhibit A,” attached herein and incorporated by reference; and

**WHEREAS**, pursuant to the Texas Attorney General Opinion No. JM-1232 and Section 34.05(a) of the Texas Property Tax Code, the City may re-sell the Properties (“the Second Sale”) subject to any right of redemption existing at the time of the Second Sale; and

**WHEREAS**, pursuant to the provisions of Chapter 34, Section 34.05 of the Texas Property Tax Code, a taxing entity is authorized to re-sell the Properties (“the Second Sale”); and

**WHEREAS**, by accepting its pro rata proceeds from the Second Sale, the State agrees to the transfer of Properties in which it has an interest; and

**WHEREAS**, the City Manager, acting on behalf of the County pursuant to a County Commissioner’s Court Order, and acting on behalf of DISD pursuant to a School Board Resolution have the authority to execute Quitclaim Deeds to the purchasers of Properties at the Second Sale, and transfer any rights, title, or interests acquired or held by each taxing entity that was a party to the Judgment at the First Sale; and

**WHEREAS**, the Properties were advertised in the Dallas Morning News on the dates indicated on Exhibit A; and

**WHEREAS**, the City Council has previously approved the re-sale of other Properties where funds were not received, nor disbursed prior to the April 1, 2001 Tax Collection Consolidation with Dallas County; and

**WHEREAS**, the distribution of the proceeds from the resale of the Properties will be in accordance with Chapter 34, Section 34.06 of the Texas Property Tax Code; **Now, Therefore,**

**BE IT RESOLVED BY THE CITY COUNCIL OF THE CITY OF DALLAS:**

April 27, 2016

**SECTION 1.** That upon receipt of the monetary consideration from the purchasers of the Properties listed on Exhibit A, and upon consent by the County and DISD, the City Manager upon approval as to form by the City Attorney and attested by the City Secretary, is hereby authorized to execute Quitclaim Deeds to the Properties, conveying to the purchasers the right, title, and interest acquired or held by each taxing entity that was a party to the Judgment, subject to any right of redemption, post-Judgment taxes and post Judgment non-municipal liens, and in accordance with the written agreement of the terms, conditions, and release of the taxing entities.

**SECTION 2.** That the consideration received from the Second Sale shall be distributed pursuant to Chapter 34, Section 34.06 of the Texas Property Tax Code, and applied to the payment of the court costs, interest, and cost of sale and applied to the amount of delinquent taxes, penalties, and non-tax municipal liens as set forth in the Judgment and pursuant to the order of the court.

**SECTION 3.** That all purchasers shall be responsible for the pro rata portion of property taxes for the remaining part of the current calendar year that will be assessed from the date of closing of the Second Sale. Purchasers shall also be responsible for any post-Judgment taxes, penalties and interest, pursuant to the Texas Property Tax Code, and post-Judgment non-municipal liens. The Properties shall be replaced on the tax rolls as of the date of execution of Quitclaim Deeds.

**SECTION 4.** That to the extent authorized by law, any liens securing taxes referenced in Section 2 above are hereby released. That the City Manager, upon approval as to form by the City Attorney, is authorized to execute a release(s) of lien for any non-tax municipal lien(s) which (i) are included in the Judgments issued in the foreclosure suits filed by the City on the lot(s) shown on Exhibit "A"; or (ii) arise or are filed of record post Judgment and prior to the Second Sale by the City on the lot(s) shown on Exhibit "A".

**SECTION 5.** That any and all proceeds from the Second Sale, including funds not received, nor disbursed prior to the April 1, 2001 Tax Collection Consolidation with Dallas County will be deposited to General Fund 0001, Department DEV, Balance Sheet Account 0519.

**SECTION 6.** That upon receipt of the consideration from the Second Sale, the Chief Financial Officer is authorized to disburse the proceeds in accordance with Chapter 34, Section 34.06 of the Texas Property Tax Code. Calculations for disbursements shall be provided by the Director of Sustainable Development and Construction to the City of Dallas Land Based Receivables, the Dallas County District Clerk, and the Dallas County Tax Office from the account specified in Section 5, above.

**SECTION 7.** That this resolution shall take effect immediately from and after its passage in accordance with the provisions of the Charter of the City of Dallas, and it is accordingly so resolved.



**TAX FORECLOSED AND SEIZURE WARRANT PROPERTY RESALES  
EXHIBIT A**

ITEM #	STREET ADDRESS	LEGAL DESCRIPTION	VAC/IMP	OWNED BY TAXING ENTITIES	DMN DATES ADVERTISEMENT	# BIDS	MINIMUM BID	HIGHEST BID AMOUNT	HIGHEST BIDDER
1	1221 10TH	Lot 6, Block 101/9084	V	1, 2, 3	2/7 & 2/8	4	\$1,000.00	\$ 1,750.00	GUADALUPE MARTINEZ
2	1131 11TH	Lot 8, Block 102/3085	V	1, 2, 3	2/7 & 2/8	2	\$1,000.00	\$1,275.00	NEXTLOTS NOW L.L.C.
3	1535 ADELAIDE	Lot 3, Block 4/4345	V	1, 2, 3	2/7 & 2/8	2	\$1,000.00	\$2,275.00	NEXTLOTS NOW L.L.C.
4	3018 ARIZONA	Lot 5, Block 19/4121	V	1, 2, 3	2/7 & 2/8	4	\$1,000.00	\$12,500.00	NEREIDA VASQUEZ
5	5511 ARLINGTON PARK	Lot 32, Block 2/7915	V	1, 2, 3	2/7 & 2/8	8	\$250.00	\$2,483.00	MASON SNEED HENSLEY
6	1619 AVENUE B	Block 5909	V	1, 2, 3	2/7 & 2/8	2	\$1,000.00	\$2,895.00	NEXTLOTS NOW L.L.C.
7	419 AVENUE L	Lot 32, Block 8/4970	V	1, 2, 3	2/7 & 2/8	1	\$1,000.00	\$1,451.00	ROLANDO COBOS
8	3300 BEAUCHAMP	Lot 1, Block H/6094	V	1, 2, 3	2/7 & 2/8	1	\$1,000.00	\$1,285.00	NEXTLOTS NOW L.L.C.
9	1822 BICKERS	Lot 9, Block M/7123	V	1, 2, 3	2/7 & 2/8	14	\$1,000.00	\$11,666.96	ANGELICA HERNANDEZ
10	3844 BLUE RIDGE	Lot 3, Block 6960	V	1, 2, 3	2/7 & 2/8	5	\$25,000.00	\$50,000.00	SHAYMAH MAHDI
11	6425 C F HAWN	Lot 32, Block 6240	V	1, 2, 3	2/7 & 2/8	6	\$4,000.00	\$21,386.00	AXXAN GREEN, INC.
12	1618 CALDWELL	Lot 3, Block B/1445	V	1, 2, 3	2/7 & 2/8	3	\$1,000.00	\$3,000.99	ALMA MIREYA REYES BARBOSA
13	1614 CALDWELL	Lot 4, Block B/1445	V	1, 2, 3	2/7 & 2/8	3	\$1,000.00	\$3,000.99	ALMA MIREYA REYES BARBOSA
14	4215 CANAL	Lot 45, Block A/1853	V	1, 2, 3	2/7 & 2/8	2	\$1,000.00	\$2,200.00	KIMIAMI ITAMURA
15	4328 CANAL	Lot 4, Block 3/1853	V	1, 2, 3	2/7 & 2/8	2	\$1,000.00	\$2,052.00	CLIFFORD JOHNSON JR.
16	3814 CARL	Block 1813	V	1, 2, 3	2/7 & 2/8	4	\$1,000.00	\$2,795.00	NEXTLOTS NOW L.L.C.
17	2437 CEDAR CREST	Tract 3	V	1, 2, 3	2/7 & 2/8	2	\$3,000.00	\$5,100.00	AUBREY QUARLES
18	1427 CEDAR OAKS	Lot 10, Block 2/3762	V	1, 2, 3	11/29 & 11/30	9	\$1,000.00	\$29,999.00	CITYWIDE DEVELOPMENT & CONSTRUCTION, LLC
19	1200 CLAUDE	Lot 11A, Block D/3364	I	1, 2, 3	2/7 & 2/8	11	\$10,000.00	\$35,000.00	ERIC AREVALO
20	1229 CLAUDE	Lot 7, Block E/3365	V	1, 2, 3	2/7 & 2/8	4	\$1,000.00	\$3,100.00	ALONSO OLMOS
21	4422 COLONIAL	Lot 6, Block F/1690	V	1, 2, 3	2/7 & 2/8	2	\$1,000.00	\$1,400.00	W. JUSTIN TITLE AND SHERRI M. TITLE

**TAX FORECLOSED AND SEIZURE WARRANT PROPERTY RESALES  
EXHIBIT A**

ITEM #	STREET ADDRESS	LEGAL DESCRIPTION	VAC/IMP	OWNED BY TAXING ENTITIES	DMN DATES ADVERTISEMENT	# BIDS	MINIMUM BID	HIGHEST BID AMOUNT	HIGHEST BIDDER
22	3815 COLONIAL	Lot 17, Block B/1260	V	1, 2, 3	2/7 & 2/8	2	\$1,000.00	\$1,385.00	MARIA SCHNEIDER, DEVAN EARLE, DORIC EARLE, AND M.W. RESNICK
23	1100 COMAL	Part of Lots 1 and 2, Block 47/3028	V	1, 2, 3	2/7 & 2/8	7	\$1,000.00	\$2,765.02	MEGAN E. KNAUSS AND STEPHANI A. KYLE
24	1102 COMAL	Part of Lot 2, Block 47/3028	V	1, 2, 3	2/7 & 2/8	7	\$1,000.00	\$2,550.00	CRISTAL BENITEZ
25	3910 COPELAND	Lot 8, Block 5/1838	V	1, 2, 3	2/7 & 2/8	5	\$250.00	\$2,100.00	KIMIAMI ITAMURA
26	4334 COPELAND	Lot L, Block 1856	V	1, 2, 3	2/7 & 2/8	2	\$250.00	\$300.00	CHRISTINA MARTINEZ AND KELLY MARTINEZ
27	3819 COPELAND	Lot 5, Block 4/1837	V	1, 2, 3	2/7 & 2/8	2	\$1,000.00	\$2,050.00	KIMIAMI ITAMURA
28	4015 COPELAND	Lot 4, Block 1/1839	V	1, 2, 3	2/7 & 2/8	3	\$250.00	\$500.00	TENA NY
29	2810 DATHE	Lot 3, Block D/1969	V	1, 2, 3	2/7 & 2/8	2	\$1,000.00	\$3,100.00	GENARO B. FIERRO
30	2415 DATHE	Lot 14, Block A/1711	I	1, 2, 3	2/7 & 2/8	8	\$3,000.00	\$15,050.00	JOSE SARAGOZA
31	1410 S. DENLEY	Part of Lots 8 and 9, Block D/3582	V	1, 2, 3	2/7 & 2/8	3	\$3,000.00	\$5,800.00	BENITO MOJICA
32	1732 S. DENLEY	Lot 9, Block 42/3716	V	1, 2, 3	2/7 & 2/8	2	\$1,000.00	\$3,075.00	NEXTLOTS NOW L.L.C.
33	1429 DICEMAN	Lot 16, Block C/7533	V	1, 2, 3	2/7 & 2/8	4	\$1,000.00	\$2,200.00	BENITO MOJICA
34	2323 ECHO LAKE	Lots 15A and 16, Block 5/8801	V	1, 2, 3	2/7 & 2/8	5	\$1,000.00	\$3,725.00	NEXTLOTS NOW L.L.C.
35	711 ELSTON	Lot 17, Block 16/6634	V	1, 2, 3	2/7 & 2/8	1	\$500.00	\$2,900.00	JDS-Q SERVICES, LLC
36	1306 EMILY	Lot 8, Block 9/7534	V	1, 2, 3	2/7 & 2/8	2	\$500.00	\$600.00	ALFONSO RUIZ
37	1310 EMILY	Lot 7, Block 9/7534	V	1, 2, 3	2/7 & 2/8	2	\$500.00	\$600.00	ALFONSO RUIZ
38	1314 EMILY	Lot 6, Block 9/7534	V	1, 2, 3	2/7 & 2/8	2	\$500.00	\$600.00	ALFONSO RUIZ
39	5608 FANNIE	East half of Lot 19, Block A/7191	V	1, 2, 3	2/7 & 2/8	4	\$500.00	\$3,280.00	DFW PROJECTS, LLC
40	1302 FOLEY	Lot 1, Block 2/1463	V	1, 2, 3	2/7 & 2/8	1	\$500.00	\$605.00	NEXTLOTS NOW L.L.C.
41	3407 FORNEY	Lot 2, Block A/2640	V	1, 2, 3	2/7 & 2/8	2	\$500.00	\$3,150.00	NEXTLOTS NOW L.L.C.

**TAX FORECLOSED AND SEIZURE WARRANT PROPERTY RESALES  
EXHIBIT A**

ITEM #	STREET ADDRESS	LEGAL DESCRIPTION	VAC/IMP	OWNED BY TAXING ENTITIES	DMN DATES ADVERTISEMENT	# BIDS	MINIMUM BID	HIGHEST BID AMOUNT	HIGHEST BIDDER
42	4314 FRANK	Lot 7, Block 1/1853	V	1, 2, 3	2/7 & 2/8	4	\$1,000.00	\$3,500.00	MAXINE HIGHTOWER
43	4326 FRANK	Lot 5, Block 1/1853	V	1, 2, 3	2/7 & 2/8	2	\$1,000.00	\$1,108.00	MARIA SCHNEIDER, DEVAN EARLE, DORIC EARLE, AND M.W. RESNICK
44	4007 FUREY	Lot 20, Block 18/7146	V	1, 2, 3	2/7 & 2/8	10	\$1,000.00	\$10,200.00	DFW PROJECTS, LLC
45	4711 GARRISON	Lot 4, Block E/5151	V	1, 2, 3	2/7 & 2/8	1	\$500.00	\$507.00	ANTHONY BOYD IRA LLC
46	1306 GLIDDEN	Lot 14, Block C/3391	V	1, 2, 3	2/7 & 2/8	1	\$250.00	\$355.00	LONNIE BARNES
47	2721 GOULD	Lot 30, Block 5/1116	V	1, 2, 3	2/7 & 2/8	5	\$1,000.00	\$5,400.02	MEGAN E. KNAUSS AND STEPHANI A. KYLE
48	2821 GOULD	Lot 39, Block 5/1116	V	1, 2, 3	2/7 & 2/8	2	\$1,000.00	\$3,571.00	DEVAN EARLE
49	4226 HAMILTON	Lot 7, Block G/1822	V	1, 2, 3	2/7 & 2/8	1	\$1,000.00	\$2,250.00	KIMIAKI ITAMURA
50	2427 HARDING	Lot 7, Block 7/2530	I	1, 2, 3	2/7 & 2/8	4	\$3,500.00	\$15,000.00	ESTEBAN MELGAREJO CASTILLO
51	4511 HEDGDON	Tract 3, Block 41/8617	V	1, 2, 3	2/7 & 2/8	2	\$2,000.00	\$6,875.00	NEXTLOTS NOW L.L.C.
52	1410 HENDRICKS	Lot 3, Block 25/3586	V	1, 2, 3	2/7 & 2/8	4	\$1,000.00	\$2,501.00	EDMOND CHIU
53	1311 HENDRICKS	Lot 29, Block 16/3576	V	1, 2, 3	2/7 & 2/8	3	\$1,000.00	\$2,435.00	NEXTLOTS NOW L.L.C.
54	2912 HOLMES	Lot 4, Block 6/1140	V	1, 2, 3	2/7 & 2/8	2	\$1,000.00	\$4,600.00	COUNTY LAND AND WATER LLC SERIES COM1
55	2630 IDAHO	Lot 8, Block 22/2886	V	1, 2, 3	2/7 & 2/8	3	\$1,000.00	\$3,125.00	NEXTLOTS NOW L.L.C.
56	4114 JAMAICA	Lot 10, Block E/1845	V	1, 2, 3	2/7 & 2/8	3	\$1,000.00	\$3,786.00	GLO-NITE, INC.
57	3623 KENILWORTH	Lot 15, Block A/2130	V	1, 2, 3	2/7 & 2/8	1	\$1,000.00	\$1,188.00	MARIA SCHNEIDER, DEVAN EARLE, DORIC EARLE, AND M.W. RESNICK
58	3504 KEYRIDGE	Lot 5, Block 18/6866	V	1, 2, 3	2/7 & 2/8	2	\$1,000.00	\$6,865.00	NEXTLOTS NOW L.L.C.
59	4947 KILDARE	Lot 4C, Block O/4366	V	1, 2, 3	2/7 & 2/8	2	\$1,000.00	\$1,875.00	NEXTLOTS NOW L.L.C.
60	2727 LAWRENCE	Lot 11, Block A/2479	I	1, 2, 3	2/7 & 2/8	2	\$6,000.00	\$10,007.00	TRI-CAPITAL EQUITIES LLC

**TAX FORECLOSED AND SEIZURE WARRANT PROPERTY RESALES  
EXHIBIT A**

ITEM #	STREET ADDRESS	LEGAL DESCRIPTION	VAC/IMP	OWNED BY TAXING ENTITIES	DMN DATES ADVERTISEMENT	# BIDS	MINIMUM BID	HIGHEST BID AMOUNT	HIGHEST BIDDER
61	2736 LEBROCK	Lot 13, Block 19/6890	V	1, 2, 3	2/7 & 2/8	1	\$500.00	\$550.00	RAQUEL ROLLINS
62	3744 LEGENDARY	Block D/6035	V	1, 2, 3	2/7 & 2/8	3	\$37,500.00	\$53,520.00	TONYA WATSON
63	2524 MARBURG	Lot 6, Block A/1957	V	1, 2, 3	2/7 & 2/8	3	\$250.00	\$500.00	W. JUSTIN TITL AND SHERRI M. TITL
64	2231 MARBURG	Lot 14, Block B/7157	V	1, 2, 3	2/7 & 2/8	2	\$500.00	\$1,000.00	W. JUSTIN TITL AND SHERRI M. TITL
65	1212 MARFA	Lot 10, Block 35/4084	V	1, 2, 3	2/7 & 2/8	1	\$1,000.00	\$1,525.00	NEXTLOTS NOW L.L.C.
66	2639 MARFA	Lot 9, Block 23/5855	V	1, 2, 3	2/7 & 2/8	1	\$500.00	\$1,375.00	NEXTLOTS NOW L.L.C.
67	5703 MARGEWOOD	Lot 17, Block 1/8028	I	1, 2, 3	2/7 & 2/8	8	\$7,000.00	\$30,100.00	CRISTAL BENITEZ AND OSCAR GARCIA
68	18 MARGEWOOD	Lot 18, Block 1/8028	V	1, 2, 3	2/7 & 2/8	5	\$2,000.00	\$10,050.00	LUIS MENDEZ AND CARLOS GUZMAN
69	2911 MARSALIS	Lot 15, Block 14/4120	V	1, 2, 3	2/7 & 2/8	7	\$1,000.00	\$14,500.00	NEREIDA VASQUEZ
70	2726 MEADOW	Lot 7, Block A/1346	V	1, 2, 3	2/7 & 2/8	5	\$500.00	\$888.00	JONATHAN BENDER
71	4223 METROPOLITAN	Lot 40, Block G/1822	V	1, 2, 3	2/7 & 2/8	3	\$1,000.00	\$1,855.00	DAPORSCHA KELLEY
72	3321 MORRIS	Lot 19, Block 13/7145	I	1, 2, 3	2/7 & 2/8	8	\$7,000.00	\$20,563.00	HOMEX CHANGE LLC DBA NOMAS HOMEX CHANGE
73	2732 PARNELL	Lot 9, Block 1/1115	V	1, 2, 3	2/7 & 2/8	2	\$1,000.00	\$1,799.00	DEVAN EARLE
74	4337 PENELOPE	Lot 10, Block 1/1849	V	1, 2, 3	2/7 & 2/8	2	\$1,000.00	\$1,207.00	DEVAN EARLE
75	1308 PENNSYLVANIA	Lot 5, Block A/1162	V	1, 2, 3	2/7 & 2/8	4	\$1,000.00	\$2,855.00	DAPORSCHA KELLEY
76	3902 PINE	Lot 6, Block 2/1836	V	1, 2, 3	2/7 & 2/8	2	\$1,000.00	\$1,456.00	FRANCISCO MUJICA
77	11700 RAVENVIEW	Part of Lots 12D and 13, Block 8797	V	1, 2, 3	2/7 & 2/8	1	\$1,000.00	\$1,500.00	OSCAR GARCIA
78	3231 REED	Lot 15, Block 2/1782	V	1, 2, 3	2/7 & 2/8	2	\$1,000.00	\$1,501.00	FRANCISCO MUJICA
79	3327 REED	Lot 25, Block B/1792	V	1, 2, 3	2/7 & 2/8	3	\$1,000.00	\$1,501.00	FRANCISCO MUJICA
80	3923 ROBERTS	Lot 16, Block 1784	I	1, 2, 3	2/7 & 2/8	1	\$5,000.00	\$5,777.00	TRI-CAPITAL EQUITIES LLC

**TAX FORECLOSED AND SEIZURE WARRANT PROPERTY RESALES  
EXHIBIT A**

ITEM #	STREET ADDRESS	LEGAL DESCRIPTION	VAC/IMP	OWNED BY TAXING ENTITIES	DMN DATES ADVERTISEMENT	# BIDS	MINIMUM BID	HIGHEST BID AMOUNT	HIGHEST BIDDER
81	7331 SCYENE	Lot 1, Block E/6126	V	1, 2, 3	2/7 & 2/8	3	\$2,000.00	\$6,400.00	BENITO MOJICA
82	8906 SEDGEMOOR	Lot 26, Block D/7590	V	1, 2, 3	11/29 & 11/30	11	\$2,000.00	\$25,399	CITYWIDE DEVELOPMENT & CONSTRUCTION, LLC
83	2624 SEEVERS	Lot 7, Block 14/4200	V	1, 2, 3	2/7 & 2/8	8	\$500.00	\$14,757.00	NEREIDA VASQUEZ
84	1903 SMOKE TREE	Lot 6, Block A/8827	V	1, 2, 3	2/7 & 2/8	6	\$1,000.00	\$4,200.00	CARMEN OLGUIN
85	1732 SMOKE TREE	Lot 16, Block B/8827	V	1, 2, 3	2/7 & 2/8	1	\$1,000.00	\$1,875.00	NEXTLOTS NOW L.L.C.
86	2714 SOUTHLAND	Lot 9, Block 8/1958	V	1, 2, 3	2/7 & 2/8	2	\$250.00	\$901.10	SAMUEL DEMISSEW
87	2374 SOUTHWOOD	Lot 14, Block B/6036	V	1, 2, 3	2/7 & 2/8	3	\$2,000.00	\$5,579.00	DEVAN EARLE
88	4603 SPRING GARDEN	Lot 9, Block E/1776	V	1, 2, 3	2/7 & 2/8	2	\$1,000.00	\$2,005.00	TONYA WATSON
89	2728 SWANSON	Lot 4, Block 2E/1854	V	1, 2, 3	2/7 & 2/8	2	\$1,000.00	\$1,605.00	TONYA WATSON
90	524 TAMA	Lot 17A, Block 3391	V	1, 2, 3	2/7 & 2/8	2	\$ 500.00	\$1,000.00	MARIA ESTRADA
91	1306 VALLEY	Lot 27, Block A/3391	V	1, 2, 3	2/7 & 2/8	3	\$1,000.00	\$2,375.00	NEXTLOTS NOW L.L.C.
92	1314 VALLEY	Lot 28, Block A/3391	V	1, 2, 3	2/7 & 2/8	3	\$500.00	\$2,575.00	NEXTLOTS NOW L.L.C.
93	4319 WILLOW SPRINGS	Lot 27, Block B/4474	I	1, 2, 3	2/7 & 2/8	6	\$7,000.00	\$22,666.96	ANGELICA HERNANDEZ
94	709 WOODBINE	Lot 2, Block 5/3870	V	1, 2, 3	2/7 & 2/8	4	\$250.00	\$1,005.00	TONYA WATSON
95	3807 YORK	Lot 12, Block 1/4462	V	1, 2, 3	2/7 & 2/8	4	\$250.00	\$755.00	TONYA WATSON
96	3531 YORK	Lot 30, Block 2/2128	V	1, 2, 3	2/7 & 2/8	5	\$250.00	\$755.00	TONYA WATSON