



**City of Dallas**

# **PARK AND RECREATION BOARD AGENDA**

**THURSDAY, APRIL 7, 2016  
DALLAS CITY HALL  
1500 MARILLA STREET, ROOM 6FN  
DALLAS, TEXAS 75201  
214-670-4078**

**9:00 am: Administration and Finance Committee, Room 6FS  
9:00 am: Planning and Design Committee, Room 6FN  
10:00 am: Park and Recreation Board, Room 6FN**

**MEMORANDUM**

RECEIVED

2016 APR -1 PM 3: 21



**DATE:** April 1, 2016

**TO:** Members of the Administration and Finance Committee of the Dallas Park and Recreation Board:  
Rodney Schlosser, Chair; Raquel A. Rollins, Co-Chair  
Barbara A. Barbee, Lawrence S. Jones, Jesse Moreno, Susan Rader, Marlon Rollins

**SUBJECT:** Notice of Meeting – Thursday – April 7, 2016 – 9:00 a.m.  
Dallas City Hall – 1500 Marilla Street – Room 6FS – Dallas, Texas 75201

---

A meeting of the Administration and Finance Committee of the Dallas Park and Recreation Board is scheduled on Thursday, April 7, 2016 at Dallas City Hall, 1500 Marilla Street, Room 6FS, Dallas, Texas 75201 at 9:00 a.m.

**AGENDA**

**ACTION ITEMS**

**PARK BOARD AGENDA ITEM NO. 3** – Bachman Lake Park (6) – Consider use of water devices and motorboats for the purpose of the Turning P.O.I.N.T. (Paraplegics on Independent Nature Trips) 26th Annual Extravaganza at Bachman Lake Park located at 3500 Northwest Highway on Saturday, June 4, 2016 – Financing: No cost consideration to the City

**PARK BOARD AGENDA ITEM NO. 4** – Reverchon Park (2) – Consider an alcohol permit request for Lear Johnson, with Carry The Load, to serve alcohol at a walk to be held at Reverchon Park located at 3505 Maple Avenue, on Thursday, May 26, 2016 through Sunday, May 29, 2016 from 6:00 a.m. – 1:00 p.m. – Estimated Revenue: \$2,250

**PARK BOARD AGENDA ITEM NO. 5** – Reverchon Park (2) – Consider an alcohol permit request for Michael Doughman, with Dallas Pride, to serve alcohol at a festival to be held at Reverchon Park located at 3505 Maple Avenue, on Sunday, September 18, 2016 from 11:00 a.m. – 7:00 p.m. – Estimated Revenue: \$3,050

**PARK BOARD AGENDA ITEM NO. 6** – Reverchon Park (2) – Consider an alcohol permit request for Robin Baldock, with Friends of Katy Trail, to serve alcohol at the annual Friends of Katy Trail 5K Run at Reverchon Park located at 3505 Maple Avenue, on Thursday, June 9, 2016, from 5:00 p.m. – 11:00 p.m. – Estimated Revenue: \$250



**DATE:** April 1, 2016

**TO:** Members of the Administration and Finance Committee of the Dallas Park and Recreation Board:  
Rodney Schlosser, Chair; Raquel A. Rollins, Co-Chair  
Barbara A. Barbee, Lawrence S. Jones, Jesse Moreno, Susan Rader, Marlon Rollins

**SUBJECT:** Notice of Meeting – Thursday – April 7, 2016 – 9:00 a.m.  
Dallas City Hall – 1500 Marilla Street – Room 6FS – Dallas, Texas 75201

---

**AGENDA**

**ACTION ITEMS**

**PARK BOARD AGENDA ITEM NO. 7** – Savage Park (14) – Consider an alcohol permit request for Swiss Avenue Home Tour at Savage Park located at 5500 Swiss Avenue on Friday, May 6, 2016 through Sunday, May 8, 2016 from 10:00 a.m. – 6:00 p.m. – Estimated Revenue: \$470

**PARK BOARD AGENDA ITEM NO. 8** – Reverchon Park (2) – Consider an alcohol permit request for Josh Harris, with Bulladoia Music Festival, to serve alcohol at Reverchon Park located at 3505 Maple Avenue, on Friday, June 3, 2016 through Sunday, June 5, 2016 from 11:00 a.m. – 10:00 p.m. – Estimated Revenue: \$3,400

**PARK BOARD AGENDA ITEM NO. 9** – Park and Recreation Department (All) – Consider a three-year master agreement for the purchase of herbicides and pesticides with SiteOne Landscape Supply in the amount of \$519,170.14, BWI Dallas/Fort Worth in the amount of \$393,044.96, Rentokil North America, Inc. dba Target Specialty Products in the amount of \$382,502.96, Winfield Solutions, LLC in the amount of \$150,456.80, N-Gulf, LLC dba Ameriturf in the amount of \$149,082.75, Turf Care of Texas, LLC in the amount of \$103,935.00, Red River Specialties, Inc. in the amount of \$96,967.70, and Helena Chemical Co. in the amount of \$54,741.00, lowest responsive and responsible bidders of eight - Total award not to exceed \$1,849,901.31 – Financing: Current Funds (subject to annual appropriations)

**NON-ACTION ITEMS**

1. Park and Recreation Department (All) – Recommendation to the Dallas City Council to amend Chapters 32 and 41 of the Dallas City Code to prohibit smoking on park grounds, without exceptions – Financing: This action has no cost consideration to the City [This item was deferred by the full Board on December 17, 2015; Committee discussion on January 7, 2016, January 21, 2016, February 4, 2016; Committee consideration on February 18, 2016; deferred by the full Board on March 10, 2016]
2. Park Partnership Agreement Update (continued)



**DATE:** April 1, 2016

**TO:** Members of the Administration and Finance Committee of the Dallas Park and Recreation Board:  
Rodney Schlosser, Chair; Raquel A. Rollins, Co-Chair  
Barbara A. Barbee, Lawrence S. Jones, Jesse Moreno, Susan Rader, Marlon Rollins

**SUBJECT:** Notice of Meeting – Thursday – April 7, 2016 – 9:00 a.m.  
Dallas City Hall – 1500 Marilla Street – Room 6FS – Dallas, Texas 75201

---

  
Dawna M. Ray, Secretary  
Park and Recreation Board

c: Dallas Park and Recreation Board Members  
Willis C. Winters, Director, Park and Recreation Board  
John D. Jenkins, Deputy Director, Park and Recreation Department  
Christine Lanners, Assistant City Attorney

"Pursuant to Section 30.06, Penal Code (trespass by license holder with a concealed handgun), a person licensed under Subchapter H, Chapter 411, Government Code (handgun licensing law), may not enter this property with a concealed handgun."

*"De acuerdo con la sección 30.06 del código penal (ingreso sin autorización de un titular de una licencia con una pistola oculta), una persona con licencia según el subcapítulo h, capítulo 411, código del gobierno (ley sobre licencias para portar pistolas), no puede ingresar a esta propiedad con una pistola oculta."*

"Pursuant to Section 30.07, Penal Code (trespass by license holder with an openly carried handgun), a person licensed under Subchapter H, Chapter 411, Government Code (handgun licensing law), may not enter this property with a handgun that is carried openly."

*"De acuerdo con la sección 30.07 del código penal (ingreso sin autorización de un titular de una licencia con una pistola a la vista), una persona con licencia según el subcapítulo h, capítulo 411, código del gobierno (ley sobre licencias para portar pistolas), no puede ingresar a esta propiedad con una pistola a la vista."*

**"A quorum of the Dallas Park and Recreation Board may attend this Dallas Park and Recreation Board Sub-Committee meeting."**

**MEMORANDUM**

**RECEIVED**



**DATE:** April 1, 2016

2016 APR -1 PM 3: 20

**TO:** Members of the Planning and Design Committee of the Dallas Park and Recreation Board: **DALLAS, TEXAS**  
Amy W. Monier, Chair; Sean Johnson, Co-Chair  
Celina Barajas, Lawrence P. Hochberg, Paul Sims, Robb P. Stewart, Yolanda F. Williams

**SUBJECT:** Notice of Meeting – Thursday – April 7, 2016 – 9:00 a.m.  
Dallas City Hall – 1500 Marilla Street – Room 6FN – Dallas, Texas 75201

---

A meeting of the Planning and Design Committee of the Dallas Park and Recreation Board is scheduled on Thursday, April 7, 2016 at Dallas City Hall, 1500 Marilla Street, Room 6FN, Dallas, Texas 75201 at 9:00 a.m.

**AGENDA**

**ACTION ITEMS**

**PARK BOARD AGENDA ITEM NO. 10** – Federal Plaza (14) – Consider preparation of a development, operation and maintenance agreement with Dallas Hartford, L.L.C. (Dallas Hartford) for the development, operation and maintenance of parkland located at Federal Plaza located at 1900 Federal Street (Exhibit A) – Financing: No cost consideration to the City

**PARK BOARD AGENDA ITEM NO. 11** – Katy Trail (14) – Consider preparation of a development and maintenance agreement with CF02 DALLAS II, LLC (CF02) for the development and maintenance of a pedestrian bridge and landscape improvements for purposes of connecting to and providing public access from an adjacent development to the Katy Trail located at 3535 Travis Street (Exhibit B) – Financing: No cost consideration to the City

**PARK BOARD AGENDA ITEM NO. 12** – Kleberg Trail (8) – Consider a public hearing to be held on May 25, 2016 to receive comments on the proposed change of use and sale of a portion of the Kleberg Trail, consisting of a total of approximately 71,109 square feet of land (Exhibits A and B), to the Texas Department of Transportation (TxDOT) for construction of improvements to I-20 Frontage Roads; and at the close of the public hearing, a resolution authorizing the proposed change of use of parkland and sale pursuant to Chapter 26 of the Texas Parks and Wildlife Code – Financing: No cost consideration to the City – Revenue: \$18,365

**PARK BOARD AGENDA ITEM NO. 13** – Urbandale Park (5) – Consider **(1)** the receipt and deposit of funds in the amount of \$70,000 in the Capital Gifts, Donation and Development Fund; **(2)** the establishment of appropriations in the Capital Gifts, Donation and Development Fund in the amount of \$70,000; and **(3)** the acceptance of Memorandum of Understanding (MOU) from the National Recreation and Park Association (NRPA) for a new playground equipment at Urbandale Park located at 7400 Ireland Avenue - Not to exceed \$70,000 – Financing: Capital Gifts, Donation and Development Funds



DATE: April 1, 2016

TO: Members of the Planning and Design Committee of the Dallas Park and Recreation Board:  
Amy W. Monier, Chair; Sean Johnson, Co-Chair  
Celina Barajas, Lawrence P. Hochberg, Paul Sims, Robb P. Stewart,  
Yolanda F. Williams

SUBJECT: Notice of Meeting – Thursday – April 7, 2016 – 9:00 a.m.  
Dallas City Hall – 1500 Marilla Street – Room 6FN – Dallas, Texas 75201

---

**AGENDA**

**ACTION ITEMS**

**PARK BOARD AGENDA ITEM NO. 14** – Runyon Creek Trail (3,8) – Consider a contract for trail improvements at Runyon Creek Trail located between Glendale Park to Camp Wisdom Road – Northstar Construction, LLC, lowest responsible bidder of two – Not to exceed \$2,497,700 – Financing: General Obligation Commercial Paper Funds (PKR-2016-00000386) [This item was deferred on March 10, 2016]

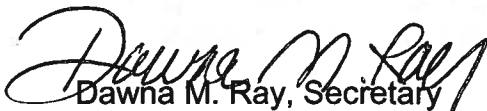
  
Dawna M. Ray, Secretary  
Park and Recreation Board

c: Dallas Park and Recreation Board Members  
Willis C. Winters, Director, Park and Recreation Department  
Louise Elam, Interim Assistant Director, Park and Recreation Department  
Christine Lanners, Assistant City Attorney  
Rosa A. Rios, City Secretary

"Pursuant to Section 30.06, Penal Code (trespass by license holder with a concealed handgun), a person licensed under Subchapter H, Chapter 411, Government Code (handgun licensing law), may not enter this property with a concealed handgun."

*"De acuerdo con la sección 30.06 del código penal (ingreso sin autorización de un titular de una licencia con una pistola oculta), una persona con licencia según el subcapítulo h, capítulo 411, código del gobierno (ley sobre licencias para portar pistolas), no puede ingresar a esta propiedad con una pistola oculta."*

"Pursuant to Section 30.07, Penal Code (trespass by license holder with an openly carried handgun), a person licensed under Subchapter H, Chapter 411, Government Code (handgun licensing law), may not enter this property with a handgun that is carried openly."

*"De acuerdo con la sección 30.07 del código penal (ingreso sin autorización de un titular de una licencia con una pistola a la vista), una persona con licencia según el subcapítulo h, capítulo 411, código del gobierno (ley sobre licencias para portar pistolas), no puede ingresar a esta propiedad con una pistola a la vista."*

**"A quorum of the Dallas Park and Recreation Board may attend this Dallas Park and Recreation Board Sub-Committee meeting."**

**MEMORANDUM**

**RECEIVED**

2016 APR -1 PM 3: 20

**CITY SECRETARY  
DALLAS, TEXAS**



**DATE:** April 1, 2016

**TO:** Max W. Wells, President, and  
Members of the Dallas Park and Recreation Board

**SUBJECT:** Notice of Regular Meeting – Thursday – April 7, 2016 – 10:00 a.m.  
Dallas City Hall – 1500 Marilla Street – Room 6FN – Dallas, Texas 75201

---

A Regular Meeting of the Dallas Park and Recreation Board is scheduled on Thursday, April 7, 2016 at Dallas City Hall, 1500 Marilla Street, Room 6FN, Dallas, Texas 75201 at 10:00 a.m. A copy of the agenda is attached.

  
Dawna M. Ray, Secretary  
Park and Recreation Board

- c: Barbara A. Barbee, Park Boardmember, Council District 1
- Jesse Moreno, Vice President, Council District 2
- Marlon Rollins, Park Boardmember, Council District 3
- Lawrence P. Hochberg, Park Boardmember, Council District 4
- Yolanda F. Williams, Park Boardmember, Council District 5
- Celina Barajas, Park Boardmember, Council District 6
- Sean Johnson, Park Boardmember, Council District 7
- Raquel A. Rollins, Park Boardmember, Council District 8
- Susan Rader, Park Boardmember, Council District 9
- Robb P. Stewart, Park Boardmember, Council District 10
- Amy W. Monier, Park Boardmember, Council District 11
- Rodney Schlosser, Park Boardmember, Council District 12
- Lawrence S. Jones, Park Boardmember, Council District 13
- Paul Sims, Park Boardmember, Council District 14
- Willis C. Winters, Director, Park and Recreation Department
- John D. Jenkins, Deputy Director, Park and Recreation Department
- Christine Lanners, Assistant City Attorney
- Rosa A. Rios, City Secretary

**DALLAS PARK AND RECREATION BOARD AGENDA**

**DALLAS CITY HALL  
1500 MARILLA STREET, ROOM 6FN  
DALLAS, TEXAS 75201  
THURSDAY, APRIL 7, 2016  
(10:00 A.M.)**

**RECEIVED**

2016 APR -1 PM 3: 20

**CITY SECRETARY  
DALLAS, TEXAS**

**MEETINGS:**

- 9:00 am: Administration and Finance Committee, Dallas City Hall, Room 6FS  
9:00 am: Planning and Design Committee, Dallas City Hall, Room 6FN  
10:00 am: Park and Recreation Board, Dallas City Hall, Room 6FN  
(Public Speakers sign in by 9:30 a.m.)
- 

1. Speakers

**MINUTES**

2. Approval of Minutes of the March 10, 2016 Park and Recreation Board Meeting

**CONSENT AGENDA (ITEMS 3 – 13)**

**ADMINISTRATION AND FINANCE COMMITTEE – MISCELLANEOUS**

3. Bachman Lake Park (6) – Authorize use of water devices and motorboats for the purpose of the Turning P.O.I.N.T. (Paraplegics on Independent Nature Trips) 26th Annual Extravaganza at Bachman Lake Park located at 3500 Northwest Highway on Saturday, June 4, 2016 – Financing: No cost consideration to the City
4. Reverchon Park (2) – Authorize an alcohol permit request for Lear Johnson, with Carry The Load, to serve alcohol at a walk to be held at Reverchon Park located at 3505 Maple Avenue, on Thursday, May 26, 2016 through Sunday, May 29, 2016 from 6:00 a.m. – 1:00 p.m. Estimated Revenue: \$2,250
5. Reverchon Park (2) – Authorize an alcohol permit request for Michael Doughman, with Dallas Pride, to serve alcohol at a festival to be held at Reverchon Park located at 3505 Maple Avenue, on Sunday, September 18, 2016 from 11:00 a.m. – 7:00 p.m. – Estimated Revenue: \$3,050
6. Reverchon Park (2) – Authorize an alcohol permit request for Robin Baldock, with Friends of Katy Trail, to serve alcohol at the annual Friends of Katy Trail 5K Run at Reverchon Park located at 3505 Maple Avenue, on Thursday, June 9, 2016, from 5:00 p.m. – 11:00 p.m. – Estimated Revenue: \$250
7. Savage Park (14) – Authorize an alcohol permit request for Swiss Avenue Home Tour at Savage Park located at 5500 Swiss Avenue on Friday, May 6, 2016 through Sunday, May 8, 2016 from 10:00 a.m. – 6:00 p.m. – Estimated Revenue: \$470



**DALLAS PARK AND RECREATION BOARD AGENDA – PAGE 2**  
**DALLAS CITY HALL, 1500 MARILLA STREET, ROOM 6FN**  
**DALLAS, TEXAS 75201**  
**THURSDAY, APRIL 7, 2016**  
**(10:00 A.M.)**

**CONSENT AGENDA (CONTINUED)**

**ADMINISTRATION AND FINANCE COMMITTEE – MISCELLANEOUS**

8. Reverchon Park (2) – Authorize an alcohol permit request for Josh Harris, with Bulladoia Music Festival, to serve alcohol at Reverchon Park located at 3505 Maple Avenue, on Friday, June 3, 2016 through Sunday, June 5, 2016 from 11:00 a.m. – 10:00 p.m. – Estimated Revenue: \$3,400
9. Park and Recreation Department (All) – Authorize a three-year master agreement for the purchase of herbicides and pesticides with SiteOne Landscape Supply in the amount of \$519,170.14, BWI Dallas/Fort Worth in the amount of \$393,044.96, Rentokil North America, Inc. dba Target Specialty Products in the amount of \$382,502.96, Winfield Solutions, LLC in the amount of \$150,456.80, N-Gulf, LLC dba Ameriturf in the amount of \$149,082.75, Turf Care of Texas, LLC in the amount of \$103,935.00, Red River Specialties, Inc. in the amount of \$96,967.70, and Helena Chemical Co. in the amount of \$54,741.00, lowest responsive and responsible bidders of eight - Total award not to exceed \$1,849,901.31 – Financing: Current Funds (subject to annual appropriations)

**PLANNING AND DESIGN COMMITTEE – MISCELLANEOUS**

10. Federal Plaza (14) – Authorize preparation of a development, operation and maintenance agreement with Dallas Hartford, L.L.C. (Dallas Hartford) for the development, operation and maintenance of parkland located at Federal Plaza located at 1900 Federal Street (Exhibit A) – Financing: No cost consideration to the City
11. Katy Trail (14) – Authorize preparation of a development and maintenance agreement with CF02 DALLAS II, LLC (CF02) for the development and maintenance of a pedestrian bridge and landscape improvements for purposes of connecting to and providing public access from an adjacent development to the Katy Trail located at 3535 Travis Street (Exhibit B) – Financing: No cost consideration to the City
12. Kleberg Trail (8) – Authorize a public hearing to be held on May 25, 2016 to receive comments on the proposed change of use and sale of a portion of the Kleberg Trail, consisting of a total of approximately 71,109 square feet of land (Exhibits A and B), to the Texas Department of Transportation (TxDOT) for construction of improvements to I-20 Frontage Roads; and at the close of the public hearing, a resolution authorizing the proposed change of use of parkland and sale pursuant to Chapter 26 of the Texas Parks and Wildlife Code – Financing: No cost consideration to the City – Revenue: \$18,365

**DALLAS PARK AND RECREATION BOARD AGENDA – PAGE 3  
DALLAS CITY HALL, 1500 MARILLA STREET, ROOM 6FN  
DALLAS, TEXAS 75201  
THURSDAY, APRIL 7, 2016  
(10:00 A.M.)**

**CONSENT AGENDA (CONTINUED)**

**PLANNING AND DESIGN COMMITTEE – MISCELLANEOUS**

13. Urbandale Park (5) – Authorize (1) the receipt and deposit of funds in the amount of \$70,000 in the Capital Gifts, Donation and Development Fund; (2) the establishment of appropriations in the Capital Gifts, Donation and Development Fund in the amount of \$70,000; and (3) the acceptance of Memorandum of Understanding (MOU) from the National Recreation and Park Association (NRPA) for a new playground equipment at Urbandale Park located at 7400 Ireland Avenue – Not to exceed \$70,000 – Financing: Capital Gifts, Donation and Development Funds

**ITEM FOR INDIVIDUAL CONSIDERATION**

**PLANNING AND DESIGN COMMITTEE – CONTRACT AWARDS**

14. Runyon Creek Trail (3,8) – Authorize a contract for trail improvements at Runyon Creek Trail located between Glendale Park to Camp Wisdom Road – Northstar Construction, LLC, lowest responsible bidder of two – Not to exceed \$2,497,700 – Financing: General Obligation Commercial Paper Funds (PKR-2016-00000386) [This item was deferred on March 10, 2016]

**NON-ACTION ITEM**

15. Recent Police Activity in the Park System:  
Rick Watson, Deputy Chief, Dallas Police Department

**BRIEFING**

16. Proposed Management Agreement with Fair Park Texas Foundation:  
Willis Winters, Director, Park and Recreation Department

**OTHER/NON-ACTION ITEMS**

17. FY 2014/15 Park and Recreation Board Annual Report
18. Committee Reports
19. Trinity Standing Wave Update
20. Texas Recreation and Parks Society Institute Reports

**DALLAS PARK AND RECREATION BOARD AGENDA – PAGE 4**  
**DALLAS CITY HALL, 1500 MARILLA STREET, ROOM 6FN**  
**DALLAS, TEXAS 75201**  
**THURSDAY, APRIL 7, 2016**  
**(10:00 A.M.)**

**OTHER/NON-ACTION ITEMS**

21. Park and Recreation Board Members Liaison Reports: Audubon Dallas/Cedar Ridge Preserve, Cultural Affairs Commission, Dallas Arboretum and Botanical Society, Dallas Zoological Society, Downtown Dallas, Inc./Downtown Parks, Friends of Fair Park, The Friends of Katy Trail, Lee Park and Arlington Hall Conservancy, State Fair of Texas, Texas Discovery Gardens, The Trinity Commons Foundation, Trinity River Audubon Center, Turtle Creek Association, The Woodall Rodgers Park Foundation/Klyde Warren Park
22. Staff Announcements – Upcoming Park and Recreation Department Events
23. Next Park and Recreation Board Regular Meeting: Thursday, April 21, 2016
24. Adjournment

A closed session may be held if the deliberation on any agenda item concerns one of the following:

1. Contemplated or pending litigation or matters where legal advice is requested of the City Attorney. Section 551.071 of Texas Open Meetings Act (T.O.M.A.)
2. The purchase, exchange, lease or value of real property, if the deliberation in an open meeting would have a detrimental effect on the position of the City in negotiations with a third person. Section 551.072 of the T.O.M.A.
3. A contract for a prospective gift or donation to the City, if the deliberation in an open meeting would have a detrimental effect on the position of the City in negotiations with a third person. Section 551.073 of the T.O.M.A.
4. Personnel matters involving the appointment, employment, evaluation, reassignment, duties, discipline or dismissal of a public officer or employee or to hear a complaint against an officer or employee. Section 551.074 of the T.O.M.A.
5. The deployment, or specific occasions for implementation of security personnel or devices. Section 551.076 of the T.O.M.A. Deliberations regarding Economic Development negotiations. Section 551.087 of the T.O.M.A.
6. Deliberations regarding Economic Development negotiations. Section 551.087 of the T.O.M.A.

"Pursuant to Section 30.06, Penal Code (trespass by license holder with a concealed handgun), a person licensed under Subchapter H, Chapter 411, Government Code (handgun licensing law), may not enter this property with a concealed handgun."

"De acuerdo con la sección 30.06 del código penal (ingreso sin autorización de un titular de una licencia con una pistola oculta), una persona con licencia según el subcapítulo h, capítulo 411, código del gobierno (ley sobre licencias para portar pistolas), no puede ingresar a esta propiedad con una pistola oculta."

"Pursuant to Section 30.07, Penal Code (trespass by license holder with an openly carried handgun), a person licensed under Subchapter H, Chapter 411, Government Code (handgun licensing law), may not enter this property with a handgun that is carried openly."

"De acuerdo con la sección 30.07 del código penal (ingreso sin autorización de un titular de una licencia con una pistola a la vista), una persona con licencia según el subcapítulo h, capítulo 411, código del gobierno (ley sobre licencias para portar pistolas), no puede ingresar a esta propiedad con una pistola a la vista."

Regular Meeting: Max W. Wells, President, presiding

Present: Max W. Wells, President; Jesse Moreno, Vice President; Celina Barajas, Barbara A. Barbee, Lawrence Hochberg, Sean Johnson, Lawrence S. Jones, Amy W. Monier, Susan Rader, Marlon Rollins, Raquel Rollins, Rodney Schlosser, Paul Sims, Robb Stewart, Yolanda F. Williams – 15

Absent: None

President Wells convened the regular meeting at 10:00 a.m. A quorum of the Board was present.

Agenda Item 1. Speakers:

1. Vanessa Ruiz – smoking ban.
2. Gay Donnell – smoking ban exceptions.
3. Jim Henderson – smoking ban.
4. Al Olsen – smoking ban.
5. Mickey Piersall – smoking at golf course.
6. Carol Walton - Fair Park.
7. Wood Cantrell – Cedar Ridge Preserve smoking.

**MINUTES**

Agenda Item 2. A motion by Barbara Barbee, seconded by Amy Monier, for approval of Minutes of the February 18, 2016 Park and Recreation Board Meeting, was carried. The vote was unanimous.

DRAFT

**CONSENT AGENDA (ITEMS 3 - 8)**

**PLANNING AND DESIGN COMMITTEE – CONTRACT AWARDS**

Agenda Item 3. Reverchon Park (2) – A motion by Rodney Schlosser, seconded by Barbara Barbee, to authorize an alcohol permit request for Katie Purell, with the Rise School, to serve alcohol at a run to be held at Reverchon Park located at 3505 Maple Avenue, on Sunday, April 23, 2016 from 6:00 a.m. – 12:00 p.m. – Estimated Revenue: \$1,250, was carried. The vote was unanimous.

**BACKGROUND**

The Park and Recreation Board has the authority by City Code Section 32-11.2(3) to approve alcohol consumption on park property. Katie Purell, with Rise School, is requesting to serve alcohol from 6:00 a.m. – 12:00 p.m. at a run, to be held at Reverchon Park, located at 3505 Maple Avenue, on Sunday, April 23, 2016. The event, with an estimated attendance of 1,000, will include the sale of beer and wine, kid's activities, and music entertainment. Park and Recreation Board approval of alcohol permit is requested.

The Alcoholic Beverage Permit Conditions document has been given to the event organizers who will be required to meet all of the conditions to include (1) Naming the City of Dallas as an Additional Insured as specified by the City's Risk Management Office and (2) alcohol consumption will be restricted to a designated enclosed area staffed by Dallas Police.

**FISCAL INFORMATION**

Event organizers will pay a \$250 alcohol permit fee, \$1,000 special event fee and a \$450 refundable cleanup deposit. Estimated Revenue is \$1,250.

Agenda Item 4. Cedar Crest Golf Course (4) – A motion by Rodney Schlosser, seconded by Barbara Barbee, to authorize an amendment to the one-hundred-twenty-six-month concessions contract with Ira McGraw, dba IAMJ Enterprises, Inc., to define roles, responsibilities and compensation as a result of the closure of the Cedar Crest Golf Course and Banquet Facility located at 1800 Southerland Avenue – Not to exceed \$239,925 – Financing: Golf Improvement Funds, was carried. The vote was unanimous.

## **BACKGROUND**

Cedar Crest Golf Course opened for play in 1918 and has not been renovated since 2003. The renovation of the existing golf course includes, bunker replacement, greens contouring and replacement, soil preparation, grassing, and landscape form and planting selections, and tee box improvements. Golf course renovations are necessary to retain a product that will generate attendance and revenues required to sustain the golf system through operations and capital improvements. The City has successfully renovated courses with golf revenues, of which are consistently recognized throughout the metroplex as top quality golf destinations and top performers.

This action will amend the management contract with Ira McGraw that was approved on June 11, 2008, by Resolution No. 08-1654 for the management of the pro shop operations. The City of Dallas golf course facility and grounds operations are managed through city forces and the business operations are managed by private contractors who are PGA Professionals. This public/private contractual partnership maximizes the revenue potential and return on investment for both the operator and the City of Dallas.

The golf course renovation will close the course during busy golfing season, during which time the golf pro will have no opportunity to generate revenue from the facilities but will continue to have financial responsibility for many aspects of the operation. During the period of the renovation, the golf pro will be preparing the marketing plan for the course re-opening and by providing professional input during the course construction regarding the final product including landscaping selection, greens, and tee box sculpting. The City proposes to compensate Mr. McGraw for professional services compensation not to exceed \$51,047 during the period of closure for his professional oversight during construction. The proposed professional compensation is based on other municipal contract comparables during golf course renovations.

Substantiated and validated expenses of approximately \$88,909 will be incurred by Mr. McGraw, against which he has no opportunity to generate revenue. During the period the course will be closed, expenses include maintaining the telephone lines, liquor license, insurance, pest control and golf shop security system. The costs for staff to close and re-open the pro shop and café, and losses for merchandise liquidation are also considered for compensation.

During the term of the renovation and seven months after reopening the course, the City will assume all utility costs for the golf course, pro shop and cart barn in an amount not to exceed \$8,591.

The City, through its Park and Recreation Department, agrees to compensate Ira McGraw a sum of \$91,378 for Concessionaires closure relief as a result of loss of revenue during closure of the golf course and to account for the time it will take to regenerate the customer base of Cedar Crest Golf Course which has dropped during the course of the last few seasons. Over the course of the last three years, the rounds at Cedar Crest have declined due to the continued decline in the condition of the greens. This decline has impacted the perception of the golfing public and by allocating these funds to Mr. McGraw, he will have the opportunity to create new golf programs, invest in staff and create additional opportunities to generate interest in Cedar Crest Golf Course and to rebuild the customer base.

The City's proposed compensation breaks down as follows:

Pro compensation	\$ 51,047
Fixed cost reimbursement	\$ 88,909
Forego seven months of utilities beginning October 2016	\$ 8,591
Commissions waiver (five months waived)	\$ 18,749
Customer Base Regeneration	<u>\$ 72,629</u>
Total Proposed Supplemental Agreement	\$239,925

#### **PLANNING AND DESIGN COMMITTEE – CONTRACT AWARDS**

Agenda Item 5. Fair Oaks Tennis Center (10), Fretz Tennis Center (11), Kiest Tennis Center (4), L.B. Houston Tennis Center (6) – A motion by Amy Monier, seconded by Robb Stewart, to defer item, authorize a contract for tennis court resurfacing at Fair Oaks Tennis Center located at 7501 Merriman Parkway, Fretz Tennis Center located at 6998 Beltline Road, Kiest Tennis Center located at 2324 West Kiest Boulevard, and L.B. Houston Tennis Center located at 11225 Luna Road - Hellas Construction, Inc., lowest responsible bidder of two - Not to exceed \$390,940 - Financing: Current Funds (PKR-2016-00000365), was carried. The vote was unanimous.

Agenda Item 6. Robert E. Lee Park (14) – A motion by Amy Monier, seconded by Robb Stewart, to defer item, authorize a contract for renovation of historic roque courts at Robert E. Lee Park located at 3400 Turtle Creek Boulevard – Henneberger Construction, Inc., lowest responsible bidder of two – Not to exceed \$353,682 – Financing: 2006 Bond Funds (\$322,682) and 2003 Bond Funds (\$31,000) (PKR-2016-00000385), was carried. The vote was unanimous.

Agenda Item 7. Runyon Creek Trail (3,8) – A motion by Amy Monier, seconded by Robb Stewart, to defer item, authorize a contract for trail improvements at Runyon Creek Trail located at between Glendale Park to Camp Wisdom Road – Northstar Construction, LLC, lowest responsible bidder of two – Not to exceed \$2,497,700 – Financing: General Obligation Commercial Paper Funds (PKR-2016-00000386), was carried. The vote was unanimous.

#### **PLANNING AND DESIGN COMMITTEE – PLANS AND SPECIFICATIONS**

Agenda Item 8. Kidd Springs Park (1) – A motion by Amy Monier, seconded by Robb Stewart, to authorize proceeding with advertisement for construction procurement for dam safety and shoreline improvements for the pond at Kidd Springs Park located at 700 West Canty Street – Estimated Cost: \$660,000 – Financing: 2006 Bond Funds, was carried. The vote was unanimous.

#### **BACKGROUND**

The Texas Commission on Environmental Quality (TCEQ) identified emergency spillway and erosion control improvements needed for the dam at the park. Landscape improvements for the natural spring and shoreline on the west side of the pond will be an add alternate. In January 2015, Half Associates, Inc. was retained by the Park and Recreation Department to investigate and provide design services to improve the spillway, repair the erosion along the dam, and provide landscape improvements.

##### Base Bid

- Emergency spillway improvements
- Erosion repairs

##### Alternate

- Landscape improvements

##### Schedule

- Began Design February 2015
- Completed Design March 2016
- Begin Construction August 2016
- Complete Construction April 2017

There are no associated new operating and maintenance costs for this project.

### **FISCAL INFORMATION**

2006 Bond Funds - \$660,000

### **PARK AND RECREATION BOARD – MARKETING COMMITTEE**

Agenda Item 9. Strategic Communications and Marketing Plan Briefing was presented by Daniel Huerta, Assistant Director, Park and Recreation Department and Simmons Design Group. Majority of the Board selected Logo 1.

Agenda Item 10. Park and Recreation Department (All) – A motion by Yolanda Williams, seconded by Lawrence Hochberg, to authorize approval of the Strategic Communications and Marketing Plan – Financing: No cost consideration to the City [Marketing Committee consideration on February 18, 2016], was carried. The vote was unanimous.

### **BACKGROUND**

The Dallas Park and Recreation Department engaged the Simmons Design Group to develop a Strategic Communications and Marketing Plan. The plan is one of the CAPRA accreditation standards and approval of the plan presented by the Simmons Design Group is requested.

### **ITEMS FOR INDIVIDUAL CONSIDERATION**

#### **ADMINISTRATION AND FINANCE COMMITTEE – MISCELLANEOUS**

Agenda Item 11. Park and Recreation Department (All) – A motion by Sean Johnson, seconded by Jesse Moreno, to defer authorize recommendation to the Dallas City Council to amend Chapters 32 and 41 of the Dallas City Code to prohibit smoking on park grounds, without exceptions – Financing: This action has no cost consideration to the City, and send back to the Administration and Finance Committee for staff to bring back criteria for the three exceptions, was carried.

#### **NON-ACTION ITEMS**

Agenda Item 12. Recent Police Activity in the Parks item was deferred.

#### **BRIEFINGS**

Agenda Item 13. Feral Hogs: Concerns, Challenges and Controls presented by Oscar Carmona, Assistant Director, Park and Recreation Department and Brett Johnson, Urban Biologist, Park and Recreation Department.

Agenda Item 14. Smart Growth for Dallas presented by Willis Winters, Director, Park and Recreation Department; The Trust for Public Land; buildingcommunityWORKSHOP; and The Texas Trees Foundation.

Agenda Item 15. FY2016/17 Budget Update presented by John Jenkins, Deputy Director, Park and Recreation Department.

#### **OTHER/NON-ACTION ITEMS**

Agenda Item 16. Committee Reports deferred.

Agenda Item 17. Trinity River Standing Wave presented by Louise Elam, Interim Assistant Director, Park and Recreation Department.

Agenda Item 18. Dallas Aquatics Master Plan – Public Meeting Update presented by Louise Elam, Interim Assistant Director, Park and Recreation Department.

Agenda Item 19. Texas Recreation and Parks Society Institute Reports deferred.

Agenda Item 20. Park and Recreation Board Members Liaison Reports: Audubon Dallas/Cedar Ridge Preserve, Cultural Affairs Commission, Dallas Arboretum and Botanical Society, Dallas Zoological Society, Downtown Dallas, Inc./Downtown Parks, Friends of Fair Park, The Friends of Katy Trail, Lee Park and Arlington Hall Conservancy, State Fair of Texas, Texas Discovery Gardens, The Trinity Commons Foundation, Trinity River Audubon Center, Turtle Creek Association, The Woodall Rodgers Park Foundation/Klyde Warren Park.

Jesse Moreno: Lonestar Legacy Award for Reverchon Park awarded at Texas Recreation and Parks Society Conference.

Celina Barajas: 17th Annual Ceremony of Don Benito Juarez.

Agenda Item 21. Staff Announcements – Upcoming Park and Recreation Department Events:

Louise Elam: Preservation Dallas Award for Sharrock-Niblo Log Cabin Restoration.

Crystal Ross: Citywide Open House and Egg Hunt including Crawford Park.

Ryan O'Connor: CAPRA updates and visitation team reception.

Agenda Item 22. President Wells announced the next Park and Recreation Board Regular Meeting on Thursday, April 7, 2016.

Agenda Item 23. President Wells adjourned the Board meeting at 2:39 p.m.

Dawna M. Ray, Secretary  
Park and Recreation Board

Max W. Wells, President  
Park and Recreation Board

NOTE: For more information on discussion of any issue heard during this meeting, refer to the tape recording retained in the Park Department's Central File.

**DRAFT**



**DALLAS PARK AND RECREATION BOARD  
AGENDA SHEET**

**DATE:** April 7, 2016

**COUNCIL DISTRICT(S):** 6

**STAFF:** Daniel Huerta, 214-670-8483

---

**SUBJECT**

Authorize use of water devices and motorboats for the purpose of the Turning P.O.I.N.T. (Paraplegics on Independent Nature Trips) 26th Annual Extravaganza at Bachman Lake Park located at 3500 Northwest Highway on Saturday, June 4, 2016 – Financing: No cost consideration to the City

**BACKGROUND**

Turning P.O.I.N.T will be hosting its 26<sup>th</sup> Annual Extravaganza on Saturday, June 4, 2016 at Bachman Lake Park located at 3500 Northwest Highway. This is a recurring event and includes activities at Bachman Lake Park the recreation center, indoor swimming pool and Bachman Lake. The annual event attracts persons with various abilities and disabilities from across the county participating in twenty different activities that historically have included water skiing, scuba diving, wall climbing, fishing, archery, kayaking, skiing, and jet skiing.

Nancy Powers, event organizer is seeking approval for use of Bachman Lake and use of motorized devices. The Park and Recreation Board has the authority by City Code to authorize the use of water devices and motorboats for the purpose of recreational and sports events on lakes.

The Dallas City Code prohibits the use of motors in excess of 10.5 H.P. and other devices such as surfboards, sailboards, or water skis on White Rock Lake and/or Bachman Lake. Sections 32-40 and 32-44 of the Dallas City Code read as follows:

**SEC. 32-40: EQUIPMENT PROHIBITED ON THE WATER**

(a) A person commits an offense if he takes a surfboard, a sailboard, water skis, or other similar device on the waters of White Rock Lake, and or Bachman Lake.

(b) A person commits an offense if he operates a boat by means of a motor having a commercial-power rating in excess of 10.5 H.P. on the waters of White Rock Lake, and or Bachman Lake.

Authorize use of water devices and motorboats for the purpose of the Turning P.O.I.N.T. (Paraplegics on Independent Nature Trips) 26th Annual Extravaganza at Bachman Lake Park located at 3500 Northwest Highway on Saturday, June 4, 2016 – April 7, 2016 – Page 2

### **BACKGROUND (CONTINUED)**

It is a defense to prosecution under Subsection (a) or (b) that the person was participating in a special recreational event authorized in writing by the park and recreation board.

(c) It is a defense to prosecution us Subsection (b) that the person was a city employee operating a motor boat in the scope of his employment. (Ord. Nos. 8018: 15195)

### **SEC. 32-44. SPECIAL RECREATION EVENTS**

On certain occasions and for the purpose of recreational and sports events at White Rock Lake or Bachman Lake, the park and recreation board may authorize the use of water equipment and motorboats that are otherwise prohibited by Section 32-40. This special use shall be under the supervision of the Director of the park and recreation department. (Ord. Nos. 8018: 15195)

The boats for the Turning Point event have commercial power-rated motors of 29.5 H.P. Nancy Powers, event organizer is requesting Park and Recreation Board approval for use of water devises and motorboats needed for the event for the purpose of recreational and sports events on Bachman Lake.

The estimated attendance is 225 people. The event is required to carry insurance as specified by the City's Risk Management Office and name the City of Dallas an additional insured.

### **FISCAL INFORMATION**

No cost consideration to the City.

### **COMMITTEE ACTION**

The Administration and Finance Committee will consider this item on April 7, 2016. A recommendation will be presented to the Park and Recreation Board on the same day. This item does not require City Council approval.

### **STAFF RECOMMENDATION**

Staff recommends approval.

**DALLAS PARK AND RECREATION BOARD  
AGENDA SHEET**

**DATE:** April 7, 2016  
**COUNCIL DISTRICT(S):** 2  
**STAFF:** Daniel Huerta, 214-670-8483

---

**SUBJECT**

Authorize an alcohol permit request for Lear Johnson, with Carry The Load, to serve alcohol at a walk to be held at Reverchon Park located at 3505 Maple Avenue, on Thursday, May 26, 2016 through Sunday, May 29, 2016 from 6:00 a.m. – 1:00 p.m. - Estimated Revenue: \$2,250

**BACKGROUND**

The Park and Recreation Board has the authority by City Code Section 32-11.2(3) to approve alcohol consumption on park property. Lear Johnson, with Carry The Load, is requesting to serve alcohol from 6:00 a.m. – 1:00 p.m. at a walk, to be held at Reverchon Park, located at 3505 Maple Avenue on Thursday, May 26, 2016 through Sunday, May 29, 2016. The event, with an estimated attendance of 6,000, will include the sale of beer and wine and a walk. This is a recurring event and Park and Recreation Board approval of alcohol permit is requested.

The Alcoholic Beverage Permit Conditions document has been given to the event organizers who will be required to meet all of the conditions to include (1) Naming the City of Dallas as an Additional Insured as specified by the City's Risk Management Office and (2) alcohol consumption will be restricted to a designated enclosed area staffed by Dallas Police.

**FISCAL INFORMATION**

Event organizers will pay a \$250 alcohol permit fee, \$2,000 special event fee and a \$450 refundable cleanup deposit. Estimated Revenue is \$2,250.

**COMMITTEE ACTION**

The Administration and Finance Committee will consider this item on April 7, 2016. A recommendation will be presented to the Park and Recreation Board on the same day. This item does not require City Council approval.

**STAFF RECOMMENDATION**

Staff recommends approval.

**DALLAS PARK AND RECREATION BOARD  
AGENDA SHEET**

**DATE:** April 7, 2016  
**COUNCIL DISTRICT(S):** 2  
**STAFF:** Daniel Huerta, 214-670-8483

---

**SUBJECT**

Authorize an alcohol permit request for Michael Doughman, with Dallas Pride, to serve alcohol at a festival to be held at Reverchon Park located at 3505 Maple Avenue, on Sunday, September 18, 2016 from 11:00 a.m. – 7:00 p.m. - Estimated Revenue: \$2,600

**BACKGROUND**

The Park and Recreation Board has the authority by City Code Section 32-11.2(3) to approve alcohol consumption on park property. Michael Doughman, with Dallas Pride, is requesting to serve alcohol from 11:00 a.m. – 7:00 p.m. at a festival, to be held at Reverchon Park, located at 3505 Maple Avenue, on Sunday, September 18, 2016. The event, with an estimated attendance of 6,000, will include the sale of beer and wine, vendors, and music entertainment. This is a recurring event and Park and Recreation Board approval of alcohol permit is requested.

The Alcoholic Beverage Permit Conditions document has been given to the event organizers who will be required to meet all of the conditions to include (1) Naming the City of Dallas as an Additional Insured as specified by the City's Risk Management Office and (2) alcohol consumption will be restricted to a designated enclosed area staffed by Dallas Police.

**FISCAL INFORMATION**

Event organizers will pay a \$250 alcohol permit fee, \$2,350 special event fee and a \$450 refundable cleanup deposit. Estimated Revenue is \$2,600.

**COMMITTEE ACTION**

The Administration and Finance Committee will consider this item on April 7, 2016. A recommendation will be presented to the Park and Recreation Board on the same day. This item does not require City Council approval.

**STAFF RECOMMENDATION**

Staff recommends approval.

**DALLAS PARK AND RECREATION BOARD  
AGENDA SHEET**

**DATE:** April 7, 2016  
**COUNCIL DISTRICT(S):** 2  
**STAFF:** Daniel Huerta, 214-670-8483

---

**SUBJECT**

Authorize an alcohol permit request for Robin Baldock, with Friends of Katy Trail, to serve alcohol at the annual Friends of Katy Trail 5K Run at Reverchon Park located at 3505 Maple Avenue, on Thursday, June 9, 2016, from 5:00 p.m. – 11:00 p.m. - Estimated Revenue: \$250

**BACKGROUND**

The Park and Recreation Board has the authority by City Code (Sec.32-11.2(3)) to approve alcohol consumption on park property. A request has been received by Robin Baldock, with Friends of Katy Trail, to serve alcohol from 5:00 p.m. – 11:00 p.m., at the Friends of Katy Trail 5K Run, to be held at Reverchon Park (3505 Maple Avenue) on Thursday, June 9, 2016. The event will include beer and wine, food, local musicians, and kid's activities. This is a recurring event and Park Board approval of an alcohol permit is requested. The estimated attendance is 5,000.

The Alcoholic Beverage Permit Conditions document has been given to the event organizers who will be required to meet all of the conditions to include Naming the City of Dallas as an Additional Insured as specified by the City's Risk Management Office and alcohol consumption will be restricted to a designated enclosed area staffed by Dallas Police.

**FISCAL INFORMATION**

Event organizers will pay a \$250 alcohol permit fee and a \$450 refundable cleanup deposit. Estimated Revenue is \$250.

**COMMITTEE ACTION**

The Administration and Finance Committee will consider this request on April 7, 2016. A recommendation will be presented to the Park and Recreation Board on the same day. This item does not require City Council approval.

**STAFF RECOMMENDATION**

Staff recommends approval.

**DALLAS PARK AND RECREATION BOARD  
AGENDA SHEET**

**DATE:** April 7, 2016  
**COUNCIL DISTRICT(S):** 14  
**STAFF:** Daniel Huerta, 214-670-8483

---

**SUBJECT**

Authorize an alcohol permit request for Swiss Avenue Home Tour at Savage Park located at 5500 Swiss Avenue on Friday, May 6, 2016 through Sunday, May 8, 2016 from 10:00 a.m. – 6:00 p.m. - Estimated Revenue: \$470

**BACKGROUND**

The Park and Recreation Board has the authority by City Code (Sec.32-11.2(3) to approve alcohol consumption on park property. A request has been received by Jody Bowers, to serve alcohol from 10:00 a.m. – 6:00 p.m. at the Swiss Avenue Home Tour to be held at the Savage Park (5500 Swiss Avenue) on Friday, May 6 - Sunday, May 8, 2016. The event will include a home tour and a wine and beer garden. This is a recurring event and Park Board approval of an alcohol permit is requested.

The Alcoholic Beverage Permit Conditions document has been given to the event organizers who will be required to meet all of the conditions to include Naming the City of Dallas as an Additional Insured as specified by the City's Risk Management Office and alcohol consumption will be restricted to a designated enclosed area staffed by Dallas Police.

**FISCAL INFORMATION**

Event organizers will pay a \$220 alcohol permit fee, \$250 special event fee and a \$450 refundable cleanup deposit. Estimated Revenue is \$470.

**COMMITTEE ACTION**

The Administration and Finance Committee will consider this item on April 7, 2016. A recommendation will be presented to the Park and Recreation Board on the same day. This item does not require City Council approval.

**STAFF RECOMMENDATION**

Staff recommends approval.

**DALLAS PARK AND RECREATION BOARD  
AGENDA SHEET**

**DATE:** April 7, 2016  
**COUNCIL DISTRICT(S):** 2  
**STAFF:** Daniel Huerta, 214-670-8483

---

**SUBJECT**

Authorize an alcohol permit request for Josh Harris, with Bulladoia Music Festival, to serve alcohol at Reverchon Park located at 3505 Maple Avenue, on Friday, June 3, 2016 through Sunday, June 5, 2016 from 11:00 a.m. – 10:00 p.m. - Estimated Revenue: \$3,400

**BACKGROUND**

The Park and Recreation Board has the authority by City Code Section 32-11.2(3) to approve alcohol consumption on park property. Josh Harris, with Bulladoia Music Festival, is requesting to serve alcohol at a music festival and movie night, to be held at Reverchon Park, 3505 Maple Avenue, on June 3, 2016 through Sunday, June 5, 2016 from 11:00 a.m. – 10:00 p.m. The event, with an estimated attendance of 7,000, will include music, food, entertainment and the sale of beer and wine. Park and Recreation Board approval of an alcohol permit is requested.

The Alcoholic Beverage Permit Conditions document has been given to the event organizers who will be required to meet all of the conditions to include (1) Naming the City of Dallas as an Additional Insured as specified by the City's Risk Management Office and (2) alcohol consumption will be restricted to a designated enclosed area staffed by Dallas Police.

**FISCAL INFORMATION**

Event organizers will pay a \$250 alcohol permit fee, \$3,150 special event fee and a \$450 refundable cleanup deposit. Estimated Revenue is \$3,400.

**COMMITTEE ACTION**

The Administration and Finance Committee will consider this item on April 7, 2016. A recommendation will be presented to the Park and Recreation Board on the same day. This item does not require City Council approval.

**STAFF RECOMMENDATION**

Staff recommends approval.

**DALLAS PARK AND RECREATION BOARD  
AGENDA INFORMATION SHEET**

**DATE:** April 7, 2016

**COUNCIL DISTRICT(S):** All

**STAFF:** John Jenkins, 214-670-4073

---

**SUBJECT**

Authorize a three-year master agreement for the purchase of herbicides and pesticides with SiteOne Landscape Supply in the amount of \$519,170.14, BWI Dallas/Fort Worth in the amount of \$393,044.96, Rentokil North America, Inc. dba Target Specialty Products in the amount of \$382,502.96, Winfield Solutions, LLC in the amount of \$150,456.80, N-Gulf, LLC dba Ameriturf in the amount of \$149,082.75, Turf Care of Texas, LLC in the amount of \$103,935.00, Red River Specialties, Inc. in the amount of \$96,967.70, and Helena Chemical Co. in the amount of \$54,741.00, lowest responsive and responsible bidders of eight - Total award not to exceed \$1,849,901.31 – Financing: Current Funds (subject to annual appropriations)

**BACKGROUND**

The purpose of a master agreement is to establish firm pricing for goods or services, for a specific length of time. The goods or services are then requested on an as needed basis. This action does not encumber funds.

The material purchased from this master agreement will be used by Park and Recreation staff to control insects in turf and vegetation, and to inhibit unwanted plant growth at Fair Park, City parks, athletic fields, and golf courses.

This solicitation was structured in a manner which required bidders to submit a response using unit pricing and is to be awarded by line item to the low bidder of each line item. This bid contained 146 line items.

**M/WBE INFORMATION**

The recommended awardees have fulfilled the good faith requirements set forth in the Business Inclusion and Development (BID) Plan adopted by Council Resolution No. 08-2826 as amended.



**ETHNIC COMPOSITION**

**SiteOne Landscape Supply**

White Male	1,878	White Female	281
Black Male	90	Black Female	16
Hispanic Male	356	Hispanic Female	29
Other Male	71	Other Female	21

**BWI Dallas/Fort Worth**

White Male	30	White Female	9
Black Male	1	Black Female	0
Hispanic Male	17	Hispanic Female	1
Other Male	0	Other Female	0

**Rentokil North America, Inc. dba Target Specialty Products**

White Male	2251	White Female	815
Black Male	243	Black Female	66
Hispanic Male	472	Hispanic Female	194
Other Male	119	Other Female	64

**Winfield Solutions, LLC**

White Male	9	White Female	1
Black Male	2	Black Female	0
Hispanic Male	0	Hispanic Female	0
Other Male	0	Other Female	0

**N-Gulf, LLC dba Ameriturf**

White Male	13	White Female	3
Black Male	1	Black Female	0
Hispanic Male	1	Hispanic Female	0
Other Male	0	Other Female	0

**Turf Care of Texas, LLC**

White Male	1	White Female	0
Black Male	0	Black Female	0
Hispanic Male	0	Hispanic Female	0
Other Male	0	Other Female	0

**ETHNIC COMPOSITION (Continued)**

Red River Specialties, Inc.

White Male	48	White Female	14
Black Male	0	Black Female	3
Hispanic Male	2	Hispanic Female	0
Other Male	0	Other Female	0

Helena Chemical Co.

White Male	7	White Female	1
Black Male	0	Black Female	0
Hispanic Male	0	Hispanic Female	0
Other Male	0	Other Female	0

**BID INFORMATION**

The following bids were received from solicitation number BA1601 and opened on November 13, 2015. This bid is being awarded by line item to the lowest responsive, responsible bidder of each line item.

\*Denotes successful bidder

<b><u>Bidders</u></b>	<b><u>Address</u></b>	<b><u>Amount</u></b>
*SiteOne Landscape Supply	10588 Shady Trail Dallas, TX 75220	Multiple Lines
*BWI Dallas/Fort Worth	1418 Upfield Dr. Carrollton, TX 75006	Multiple Lines
*Rentokil North America, Inc. dba Target Specialty Products	920 S. Freeport Pkwy. #220 Coppell, TX 75019	Multiple Lines
*Winfield Solutions, LLC	1221 Champion Cir. #107 Carrollton, TX 75006	Multiple Lines
*N-Gulf, LLC dba Ameriturf	1874 Highway 77 South Italy, TX 76651	Multiple Lines
*Turf Care of Texas, LLC	1400 Berwick Dr. McKinney, TX 75070	Multiple Lines

**BID INFORMATION (Continued)**

<b><u>Bidders</u></b>	<b><u>Address</u></b>	<b><u>Amount</u></b>
*Red River Specialties, Inc.	1324 N. Hearne Ave. #120 Shreveport, LA 71107	Multiple Lines
*Helena Chemical Co.	6801 Hwy. 66 West Greenville, TX 75402	Multiple Lines

**OWNER**

**SiteOne Landscape Supply**

Doug Black, CEO

**BWI Dallas/Fort Worth**

Jim Bunch, Co-President  
Robert Bunch, Co-President

**Rentokil North America, Inc. dba Target Specialty Products**

John Myers, President

**Winfield Solutions, LLC**

Chris Policinski, President

**N-Gulf, LLC dba Ameriturf**

George Scruggs, President

**Turf Care of Texas, LLC**

Todd Gilmour, President

**Red River Specialties, Inc.**

Frank Bergonzi, President

**Helena Chemical Co.**

Mike McCarty, President

**PRIOR ACTION/REVIEW (COUNCIL, BOARD, COMMISSIONS)**

On March 23, 2016 City Council drew lots to determine the awardees of tie bids between BWI Dallas/Fort Worth, Rentokil North America dba Target Specialty Products, N-Gulf, LLC dba Ameriturf, Winfield Solutions, LLC, and Helena Chemical Co.

On November 14, 2012, City Council authorized a master agreement for the purchase of pesticides and herbicides by Resolution No. 12-2728.

**FISCAL INFORMATION**

\$1,849,901.31 – Current Funds (subject to annual appropriations)

**COMMITTEE ACTION**

The Administration and Finance Committee will consider this item on April 7, 2016. A recommendation will be presented to the Park and Recreation Board on the same day.

This item will be scheduled for City Council approval on April 27, 2016.

**STAFF RECOMMENDATION**

Staff recommends approval.

**(ADMINISTRATION AND FINANCE COMMITTEE ONLY- NON-ACTION ITEM)**

**DALLAS PARK AND RECREATION BOARD  
AGENDA SHEET**

**DATE:** April 7, 2016  
**COUNCIL DISTRICT(S):** All  
**STAFF:** Oscar Carmona, 214-670-8871

---

**SUBJECT**

Recommendation to the Dallas City Council to amend Chapter 32 and 41 of the Dallas City Code to prohibit smoking on park grounds, without exceptions – Financing: This action has no cost consideration to the City

**BACKGROUND**

Chapter 41 of the Dallas City Code generally prohibits smoking (1) in any indoor enclosed area in the City; (2) within 15 feet of any entrance to an indoor or enclosed area in the City and (3) in any area designated as nonsmoking by the owner, operator, or person in control of the area and marked with a no smoking sign complying with Section 41-3. The current code does not prohibit smoking outdoors in parks.

On November 6, 2014, the Park and Recreation Board was briefed on proposed changes to the smoking ordinance that would include a ban on smoking outdoors on park property. The briefing included information on benefits, potential challenges and peer and area city comparisons. Staff was directed by the Park and Recreation Board to continue research and to prepare proposed recommendations, changes, and exceptions for consideration by the Administration and Finance Committee of the Park and Recreation Board.

The Committee has discussed the proposed changes over the past year with input from staff. After discussion with the committee and stakeholders, staff recommended an amendment to Chapter 41 of the Dallas City Code that would make it an offense for anyone to smoke on park property, with the following exceptions:

1. Allow partners, Fair Park tenants and special events to designate smoking areas based on criteria developed by the Park and Recreation Department.
2. Allow smoking on golf courses.
3. Allow smoking on park property by actors during filming or theatrical performances as permitted by the Office of Special Events.

On February 18, 2016, the Administration and Finance Committee discussed the exceptions and voted 4-3 to recommend to the Park and Recreation Board an outright ban on smoking outdoors on park property with no exceptions.

Recommendation to the Dallas City Council to amend Chapter 32 and 41 of the Dallas City Code to prohibit smoking on park grounds, without exceptions – Financing: This action has no cost consideration to the City – April 7, 2016 – Page 2

### **BACKGROUND (CONTINUED)**

On March 10, 2016, the Park and Recreation Board deferred this item and sent the item back to the Administration and Finance Committee for further review.

### **FISCAL INFORMATION**

This action has no cost consideration to the City.

### **PRIOR ACTION**

Park and Recreation Board Briefing on November 6, 2014.

Administration and Finance Committee consideration on December 17, 2015.

Park and Recreation Board deferred the item on December 17, 2015.

Administration and Finance Committee discussion on January 7, 2016.

Administration and Finance Committee discussion on January 21, 2016.

Administration and Finance Committee discussion on February 4, 2016.

The Administration and Finance Committee considered this item on February 18, 2016, and voted to recommend that the Park and Recreation Board ban smoking outdoors on park property with no exceptions.

On March 10, 2016, the Park and Recreation Board deferred this item. The item was sent back to the Administration and Finance Committee for further review of the criteria for the three exceptions.

### **COMMITTEE ACTION**

The Administration and Finance Committee will review this item on April 7, 2016.

### **ATTACHMENT**

1. Chapter 41 of the Dallas City Code

Print

The Dallas City Code

## **CHAPTER 41 SMOKING**

---

### **ARTICLE I. GENERAL PROVISIONS.**

Sec. 41-1 . Definitions.

### **ARTICLE II. SMOKING PROHIBITIONS.**

Sec. 41-2 . Smoking prohibited in certain areas.

Sec. 41-3 . Signage and other requirements.

Secs. 41-4 thru 41-5. Reserved.

### **ARTICLE III. RESERVED.**

Secs. 41-6 thru 41-8. Reserved.

### **ARTICLE IV. ENFORCEMENT.**

Sec. 41-9 . Penalties.

### **ARTICLE V. TOBACCO-PRODUCT VENDING MACHINES.**

Sec. 41-10 . Definitions.

Sec. 41-11 . Tobacco-product vending machines prohibited; defenses.

Sec. 41-12 . Lock-out devices.

### **ARTICLE I. GENERAL PROVISIONS.**

#### **SEC. 41-1. DEFINITIONS.**

In this chapter:

(1) BAR means an establishment principally for the sale and consumption of alcoholic beverages on the premises that derives 75 percent or more of its gross revenue on a quarterly (three-month) basis from the sale or service of alcoholic beverages, as defined in the Texas

Alcoholic Beverage Code, for on-premises consumption. If an establishment is located in a hotel or motel, the gross revenues of the particular establishment, rather than the gross revenues of the entire hotel or motel, will be used in calculating the percentage of revenues derived from the sale or service of alcoholic beverages.

(2) **BILLIARDS** means any game played on a cloth-covered table with balls and cue sticks where the balls are struck by the sticks and the balls strike against one another.

(3) **BILLIARD HALL** means an establishment that:

(A) holds a valid billiard hall license issued by the city under Chapter 9A of this code;

(B) has at least 12 billiard tables that are not coin-operated available for rent to persons desiring to play billiards on the premises; and

(C) derives 70 percent or more of its gross revenue on a quarterly (three-month) basis from the sale or service of alcoholic beverages, as defined in the Texas Alcoholic Beverage Code, for on-premises consumption and from the rental of billiard tables and billiard equipment to persons desiring to play billiards on the premises.

(4) **CIGAR BAR** means a bar that derives 15 percent or more of its gross revenue on a quarterly (three-month) basis from the sale or rental of tobacco, tobacco products, smoking implements, or smoking accessories for on-premises consumption.

(5) **DIRECTOR** means the director of the department designated by the city manager to enforce and administer this chapter, or the director's designated representative.

(6) **EATING ESTABLISHMENT** means any establishment that prepares or serves food or beverages, regardless of whether the establishment provides seating or facilities for on-premises consumption. The term includes, but is not limited to, restaurants, coffee shops, cafeterias, short order cafes, fast food establishments, luncheonettes, lunchrooms, soda fountains, food carts, food vending vehicles, and catering establishments.

(7) **EMPLOYEE** means any person who works for hire at an indoor or enclosed area including an independent contractor with an assigned indoor location.

(8) **EMPLOYER** means any person who employs one or more employees.

(9) **ENCLOSED** means an area that:

(A) is closed in overhead by a roof or other covering of any material, whether permanent or temporary; and

(B) has 40 percent or more of its perimeter closed in by walls or other coverings of any material, whether permanent or temporary.

(10) **HOSPITAL** means any institution that provides medical, surgical, and overnight facilities for patients.

(11) **MINOR** means any individual under 18 years of age.

(12) **PERSON** means an individual, firm, partnership, association, or other legal entity.

(13) **RETAIL OR SERVICE ESTABLISHMENT** means any establishment that sells goods or services to the general public, including but not limited to any eating establishment, bar, hotel, motel, department store, grocery store, drug store, shopping mall, laundromat, bingo parlor, bowling center, billiard hall, or hair styling salon.

(14) **SECOND-HAND SMOKE** means ambient smoke resulting from the act of smoking.

(15) **SMOKE OR SMOKING** means inhaling, exhaling, possessing, or carrying any lighted or burning cigar or cigarette, or any pipe or other device that contains lighted or burning tobacco or tobacco products.

(16) **TOBACCO SHOP** means a retail or service establishment that derives 90 percent or more of its gross revenue on a quarterly (three-month) basis from the sale of tobacco, tobacco products, or smoking implements.

(17) **WORKPLACE** means any indoor or enclosed area where an employee works for an employer. (Ord. Nos. 18961; 19648; 25168; 27440)



## ARTICLE II. SMOKING PROHIBITIONS.

### SEC. 41-2. SMOKING PROHIBITED IN CERTAIN AREAS.

- (a) A person commits an offense if he smokes:
- (1) in any indoor or enclosed area in the city;
  - (2) within 15 feet of any entrance to an indoor or enclosed area in the city; or
  - (3) in any area designated as nonsmoking by the owner, operator, or person in control of the area and marked with a no smoking sign complying with Section 41-3.
- (b) An owner, operator, or person in control of an indoor or enclosed area in the city commits an offense if he, either personally or through an employee or agent, permits a person to smoke in the indoor or enclosed area.
- (c) For purposes of this chapter, an indoor or enclosed area includes but is not limited to the following:
- (1) An elevator.
  - (2) A hospital or nursing home.
  - (3) Any facility owned, operated, or managed by the city.
  - (4) Any retail or service establishment.
  - (5) Any workplace.
  - (6) Any facility of a public or private primary or secondary school or any enclosed theater, movie house, library, museum, or transit system vehicle.
- (d) It is a defense to prosecution under Subsection (a)(1), (a)(3), or (b) of this section if the person was smoking in a location that was:
- (1) a private residence, except that this defense does not apply when the residence is being used as a child care facility, adult day care facility, or health care facility;
  - (2) a stage or set of a production of a television program, a theatrical presentation, or a motion picture or filming event where smoking by an actor or performer is essential to the production;
  - (3) a cigar bar that:
    - (A) was lawfully operating as a cigar bar on December 10, 2008 (except that this defense does not apply if the cigar bar is expanded, is relocated, or changes majority ownership after December 10, 2008);
    - (B) does not open into any other indoor or enclosed area in which smoking is prohibited under this section;
    - (C) is not generally accessible by a minor; and
    - (D) keeps all windows and doors closed at all times except as reasonably necessary for the expeditious entering and exiting of the cigar bar;
  - (4) a tobacco shop that:
    - (A) does not open into any other indoor or enclosed area in which smoking is prohibited under this section; and
    - (B) keeps all windows and doors closed at all times except as reasonably necessary for the expeditious entering and exiting of the tobacco shop;
  - (5) an unenclosed outdoor seating area associated with an indoor or enclosed area, including but not limited to a bar, hotel, motel, or eating establishment, except that this defense does not apply if:
    - (A) the outdoor seating area is adjacent to a playground or play area for children; or

(B) the location was posted as a nonsmoking area by the owner, operator, or person in control of the establishment or area with a sign complying with Section 41-3; or

(6) a private, rented guest room in a hotel or motel that has been designated as a smoking room by the owner, operator, or person in control of the hotel or motel.

(e) It is a defense to prosecution under Subsection (a)(2) of this section if the person was smoking in a location that was an unenclosed outdoor seating area associated with an indoor or enclosed area, including but not limited to a bar, hotel, motel, or eating establishment, except that this defense does not apply if:

(1) the outdoor seating area is adjacent to a playground or play area for children; or

(2) the location was posted as a nonsmoking area by the owner, operator, or person in control of the establishment or area with a sign complying with Section 41-3. (Ord. Nos. 18961; 19648; 21109; 21109; 21614; 25168; 27440)

### **SEC. 41-3. SIGNAGE AND OTHER REQUIREMENTS.**

(a) The owner, operator, or person in control of an establishment or other area in which smoking is prohibited under Section 41-2(a)(1) or (a)(3) shall post a conspicuous sign at the main entrance to the establishment or area. The sign must contain the words "No Smoking, City of Dallas Ordinance," the universal symbol for no smoking, or other language that clearly prohibits smoking.

(b) The owner, operator, or person in control of an indoor or enclosed area to which the smoking prohibition of Section 41-2(a)(2) applies shall post a conspicuous sign at each entrance to the indoor or enclosed area. The sign must contain the words "No Smoking within 15 Feet of Entrance, City of Dallas Ordinance." The universal symbol for no smoking may be substituted for the words "No Smoking."

(c) The owner, operator, or person in control of an establishment or area in which smoking is prohibited under Section 41-2 shall remove all ashtrays from the establishment or area.

(d) It is a defense to prosecution under this section that the establishment or area is a location for which a defense to prosecution is provided under Section 41-2(d). (Ord. 27440)

### **SECS. 41-4 THRU 41-5. RESERVED.**

(Repealed by Ord. 25168)

## **ARTICLE III. RESERVED.**

### **SECS. 41-6 THRU 41-8. RESERVED.**

(Repealed by Ord. 27440)

## **ARTICLE IV. ENFORCEMENT.**

(a) A person who violates a provision of this chapter, or who fails to perform an act required of the person by this chapter, commits an offense. A person commits a separate offense each day or portion of a day during which a violation is committed, permitted, or continued.

(b) Unless specifically provided otherwise in this chapter, an offense under this chapter is punishable by a fine of \$200.

(c) The culpable mental state required for the commission of an offense under this chapter is governed by Section 1-5.1 of this code. (Ord. Nos. 18961; 19648; 21540; 25168; 27440)

## **ARTICLE V. TOBACCO-PRODUCT VENDING MACHINES.**

### **SEC. 41-10. DEFINITIONS.**

In this article:

(1) **TOBACCO-PRODUCT VENDING MACHINE** means any self-service device that, upon insertion of any coin, paper currency, token, card, key, or other item, dispenses one or more tobacco products. The term does not include any machine that is in storage, in transit, or otherwise not set up for use and operation, nor does it include any machine that is situated on a train, bus, or other public conveyance.

(2) **RESTAURANT BAR** means any area of an eating establishment, excluding the dining area:

(A) that is primarily devoted to the serving of alcoholic beverages for consumption by guests on the premises; and

(B) in which food service, if any, is only incidental to the consumption of alcoholic beverages. (Ord. Nos. 21540; 21613; 25168; 27440)

### **SEC. 41-11. TOBACCO-PRODUCT VENDING MACHINES PROHIBITED; DEFENSES.**

(a) A person commits an offense if he owns or allows the display or use of any tobacco-product vending machine upon any property within the city.

(b) It is a defense to prosecution under Subsection (a) that the tobacco-product vending machine was:

(1) situated in a premises where entry by a minor is prohibited by law;

(2) situated in a hotel, motel, bar, or restaurant bar;

(3) located in a workplace with the permission of the employer, provided that:

(A) the employer usually has no person under 18 years of age employed at the workplace; and

(B) the tobacco-product vending machine is situated at a location within the workplace to which no person other than an employee of the workplace is usually permitted to have access; or

(4) located in an eating establishment and equipped with a lock-out device that was installed, maintained, and operated in compliance with Section 41-12. (Ord. Nos. 21540; 21613; 25168; 27440)

### **SEC. 41-12. LOCK-OUT DEVICES.**

(a) A lock-out device on a tobacco-product vending machine located in an eating establishment must be installed, maintained, and operated in compliance with this section.

(b) A lock-out device may be electrical or mechanical and must be approved by the director.

(c) An owner, operator, employee, or other person in charge of an eating establishment who is at least 18 years of age shall:

(1) install and continuously maintain a lock-out device on a tobacco-product vending machine in good working order;

(2) require identification from any potential customer of the tobacco-product vending machine who appears to be under 18 years of age;

(3) physically observe all transactions in which the tobacco-product vending machine is used; and

(4) physically release the lock-out device before each sale from a tobacco-product vending machine. (Ord. Nos. 21613; 25168; 27440)

#### **SEC. 41-9. PENALTIES.**

**DALLAS PARK AND RECREATION BOARD  
AGENDA SHEET**

**DATE:** April 7, 2016  
**COUNCIL DISTRICT(S):** 14  
**STAFF:** Louise Elam, 214-670-5275  
**MAPSCO:** 45-L

---

**SUBJECT**

Authorize preparation of a development, operation, and maintenance agreement with Dallas Hartford, L.L.C. (Dallas Hartford) for the development, operation, and maintenance of parkland at Federal Plaza located at 1900 Federal Street (Exhibit A) – Financing: No cost consideration to the City

**BACKGROUND**

This action will authorize a development, operation, and maintenance agreement with Dallas Hartford for the renovation, operation, and maintenance of Federal Plaza located at 1900 Federal Street.

On March 26, 2014 City Council, by Resolutions No. 14-0526 and No. 14-0527, approved a development agreement with and expenditure of TIF funds for Dallas Hartford, such funds being supportive of redevelopment of the City Center TIF District. In addition to a minimum private investment of \$5,000,000 in the redevelopment of the 400 North St Paul Street Hartford Building, an Urban Design Peer Review Panel (UDPRP), appointed by the City Manager, required Dallas Hartford to:

- a. Include the adjacent park (Federal Plaza) in the project scope.
- b. Create linkages between the park and the renovated building, through selection of materials, lighting, landscaping, and a shade structure.
- c. Consider the potential impact of the future trolley alignment on design of the park and the public area adjacent to the building.

Such recommendations by UDPRP, and expenditure of TIF funds, are consistent with TIF Project requirements for development and redevelopment for improvement to a space for public benefit, such as City parks, open space, trails, or cultural facilities.

Authorize preparation of a development, operation, and maintenance agreement with Dallas Hartford, L.L.C. (Dallas Hartford) for the development, operation, and maintenance of parkland at Federal Plaza located at 1900 Federal Street (Exhibit A) – Financing: No cost consideration to the City – April 7, 2016 – Page 2

### **BACKGROUND (CONTINUED)**

The agreement with the Park and Recreation Board will be subject to the following terms:

1. The term is for 20 years.
2. Dallas Hartford at its own cost, is responsible for the development of the design, plans, and specifications for the improvements to be made to the park (Exhibit B). Dallas Hartford will submit the design to the Park and Recreation Department for review and approval prior to commencement of construction.
3. Dallas Hartford at their own cost, is responsible for the operation, maintenance, and repair of the park during the term of the agreement.
4. Dallas Hartford will manage the design and construction through its own consultants and contractors and will be responsible for all permits and other approvals. All consultants and contractors are required to provide insurance that is consistent with what is required by City consultants and contractors.
5. The City of Dallas will retain the right to require Dallas Hartford to modify the improvements if and when necessary to maintain public safety of the parkland.

### **FISCAL INFORMATION**

No cost consideration to the City.

### **PRIOR ACTION/REVIEW (COUNCIL, BOARDS, COMMISSIONS)**

City Council approved a development agreement with Dallas Hartford to reimburse eligible project costs by Council Resolution No. 14-0526.

City Council approved reimbursement to Dallas Hartford from TIF funds by Council Resolution No. 14-0527.

The Planning and Design Committee will consider this item on April 7, 2016 and will present a recommendation to the Park and Recreation Board on the same day.

This item will be scheduled for City Council approval on April 27, 2016.

Authorize preparation of a development, operation, and maintenance agreement with Dallas Hartford, L.L.C. (Dallas Hartford) for the development, operation, and maintenance of parkland at Federal Plaza located at 1900 Federal Street (Exhibit A) – Financing: No cost consideration to the City – April 7, 2016 – Page 3

**ATTACHMENTS**

1. Exhibits
2. Map

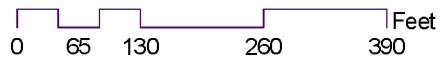
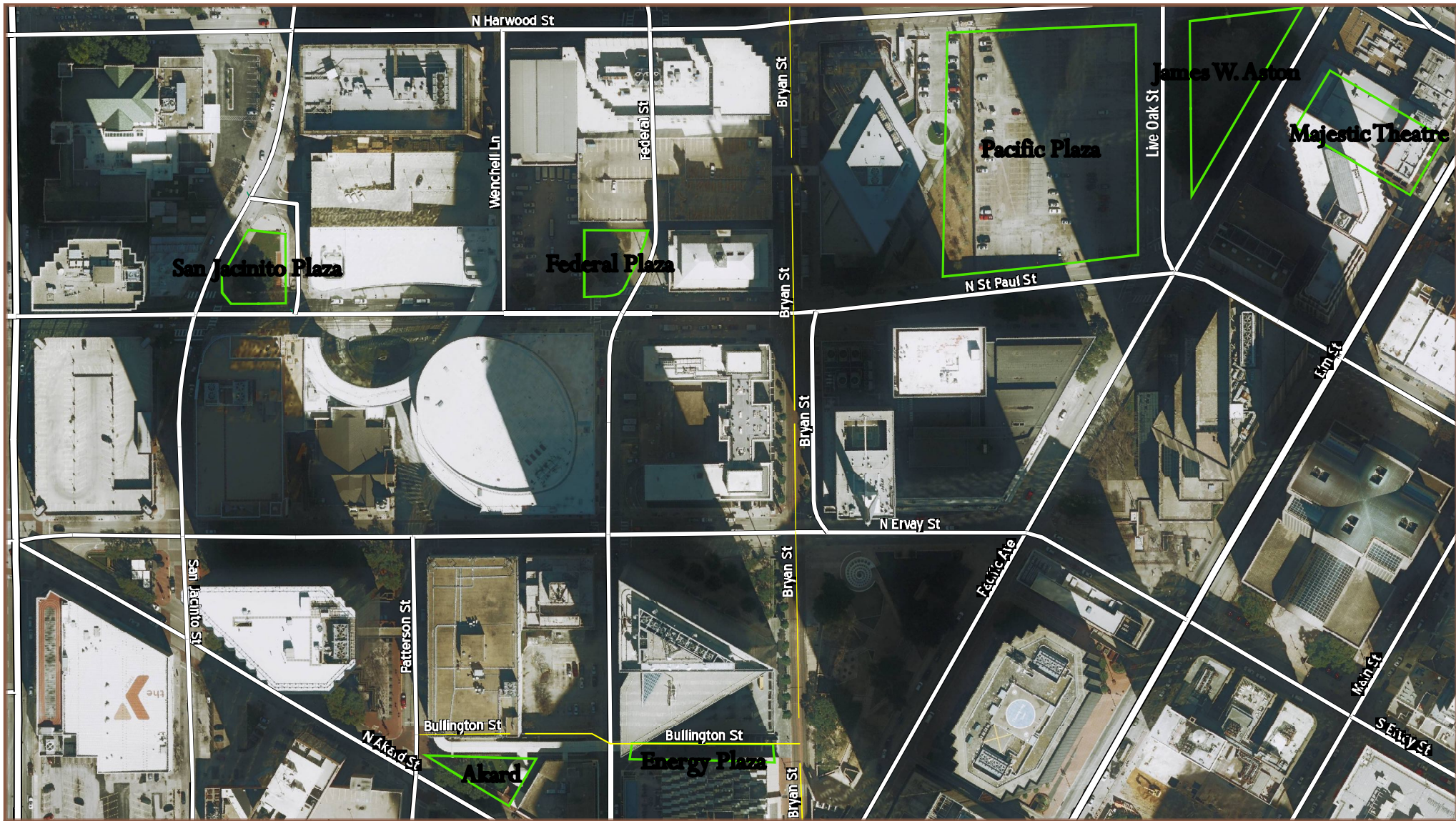

March 10, 2016

### Federal Plaza

Exhibit A  
page 1 of 2





March 10, 2016

## *Federal Plaza*

*Exhibit A*

*page 2 of 2*



October 30, 2013

REVISION

November 16, 2015

**Exhibit B**  
 Park Improvements

**Hartford Park**

400 N. ST. PAUL ST. DALLAS TEXAS 75201

FLOOR PLAN / SECTIONS

**A-1**



Cor-Tin Fence



Concrete - Rock Salt Finish

02 | MATERIAL IMAGES

3/8"=1'-0"

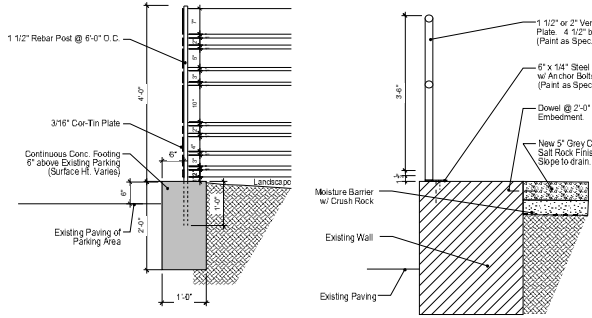

04 | SECTION DETAIL

3/8"=1'-0"

05 | SECTION DETAIL

3/8"=1'-0"

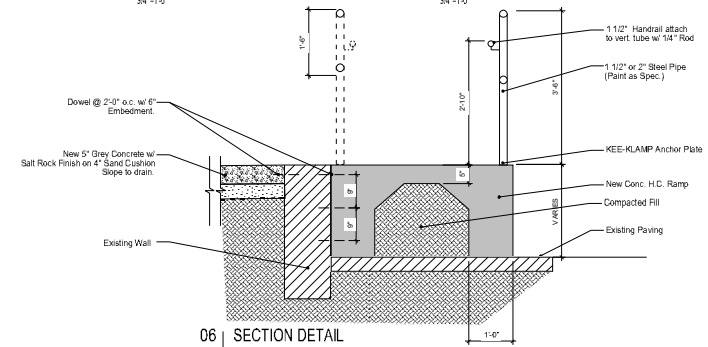

06 | SECTION DETAIL

3/8"=1'-0"

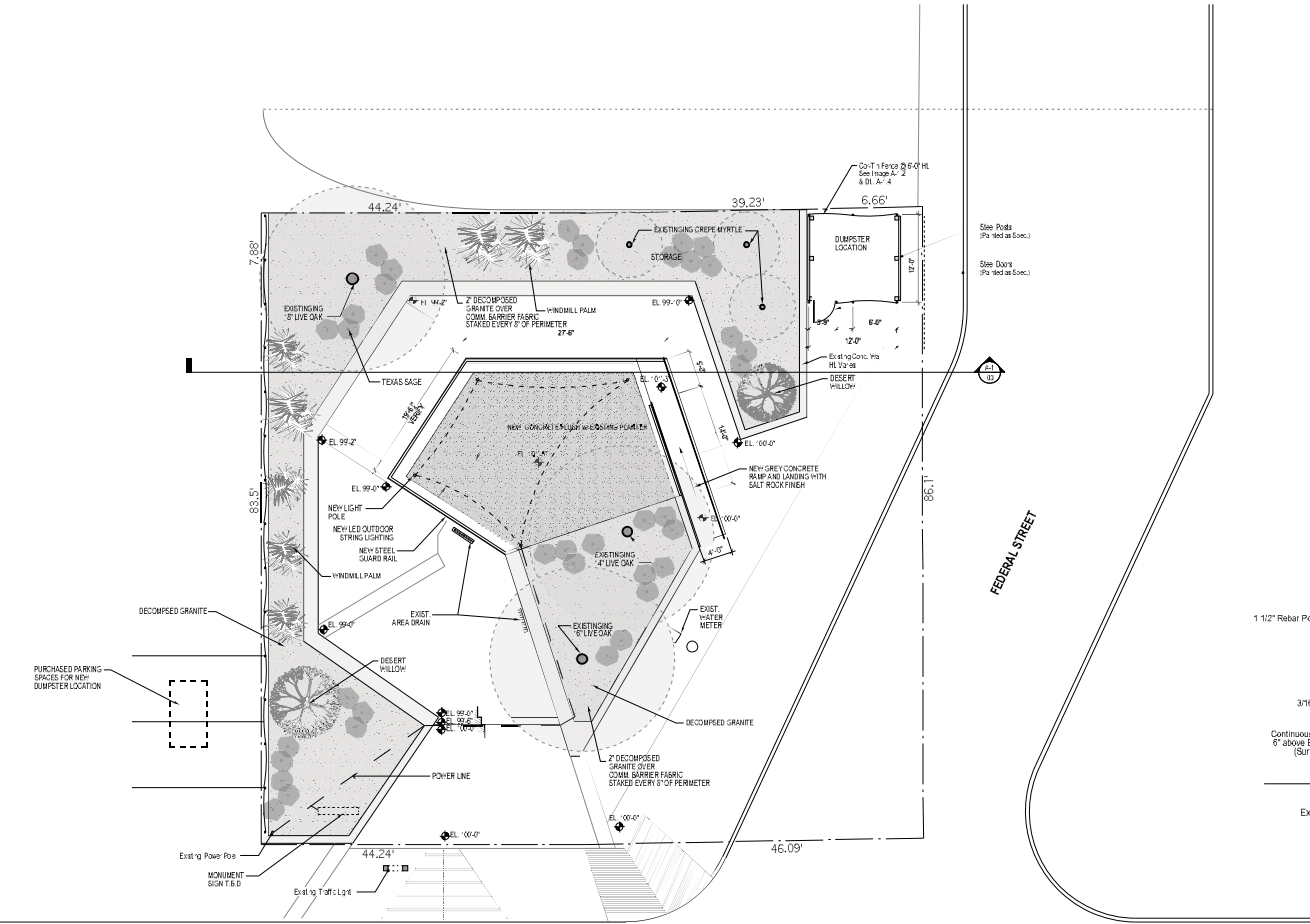

ST. PAUL STREET

01 | SITE PLAN

1/8"=1'-0"

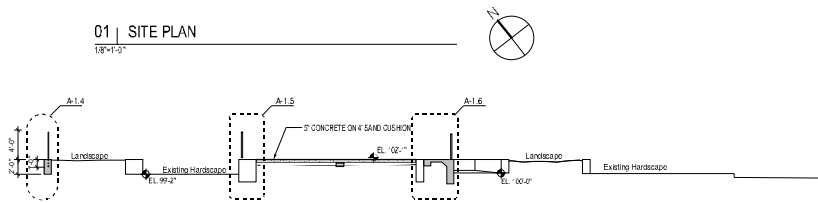

03 | SITE SECTION

1/8"=1'-0"

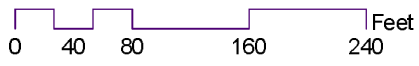

April 7, 2016

Federal Plaza  
(1900 Federal Street)

Mapsco  
45 L

District  
14

**DALLAS PARK AND RECREATION BOARD  
AGENDA SHEET**

**DATE:** April 7, 2016  
**COUNCIL DISTRICT(S):** 14  
**STAFF:** Louise Elam, 214-670-5275  
**MAPSCO:** 35-X

---

**SUBJECT**

Authorize preparation of a development and maintenance agreement with CFO2 DALLAS II, LLC (CFO2) for the development and maintenance of a pedestrian bridge and landscape improvements for purposes of connecting to and providing public access from an adjacent development to the Katy Trail located at 3535 Travis Street (Exhibit B) – Financing: No cost consideration to the City

**BACKGROUND**

This action will authorize a development and maintenance agreement with CFO2 for construction of a pedestrian bridge and landscape improvements at the Katy Trail, adjacent to 3535 Travis Street (Exhibit A).

The agreement will be subject to the following terms:

1. The term is for 20 years with one five-year renewal option.
2. CFO2 at its own cost, is responsible for the development of the design, plans, and specifications for the improvements to be made to the park. CFO2 will submit the design to the Park and Recreation Department for review and approval prior to commencement of construction.
3. CFO2 at their own cost, is responsible for the maintenance and repair of the improvements during the term of the agreement.
4. CFO2 will manage the design and construction through its own consultants and contractors and will be responsible for all permits and other approvals. All consultants and contractors are required to provide insurance that is consistent with what is required by City consultants and contractors.
5. CFO2 agrees to allow the public access to the Katy Trail from CFO2's property located at 3535 Travis Street.

Authorize preparation of a development and maintenance agreement with CFO2 DALLAS II, LLC (CFO2) for the development and maintenance of a pedestrian bridge and landscape improvements for purposes of connecting to and providing public access from an adjacent development to the Katy Trail located at 3535 Travis Street (Exhibit B) – Financing: No cost consideration to the City – April 7, 2016 – Page 2

### **BACKGROUND (CONTINUED)**

6. The City of Dallas will retain the right to require CFO2 to modify the improvements if and when necessary to maintain public safety of the Katy Trail.

### **FISCAL INFORMATION**

No cost consideration to the City.

### **PRIOR ACTION/REVIEW (COUNCIL, BOARDS, COMMISSIONS)**

City Council approved an amendment to PD 193 permitting zoning changes to the 3535 Travis Street parcel and a bridge connection to the Katy Trail by Council Resolution No. 13-1124, Ordinance #29064.

The Planning and Design Committee will review this item on April 7, 2016 and will provide a recommendation to the Park and Recreation Board on the same day.

This item will be scheduled for City Council approval on April 27, 2016.

### **ATTACHMENTS**

1. Exhibits
2. Map

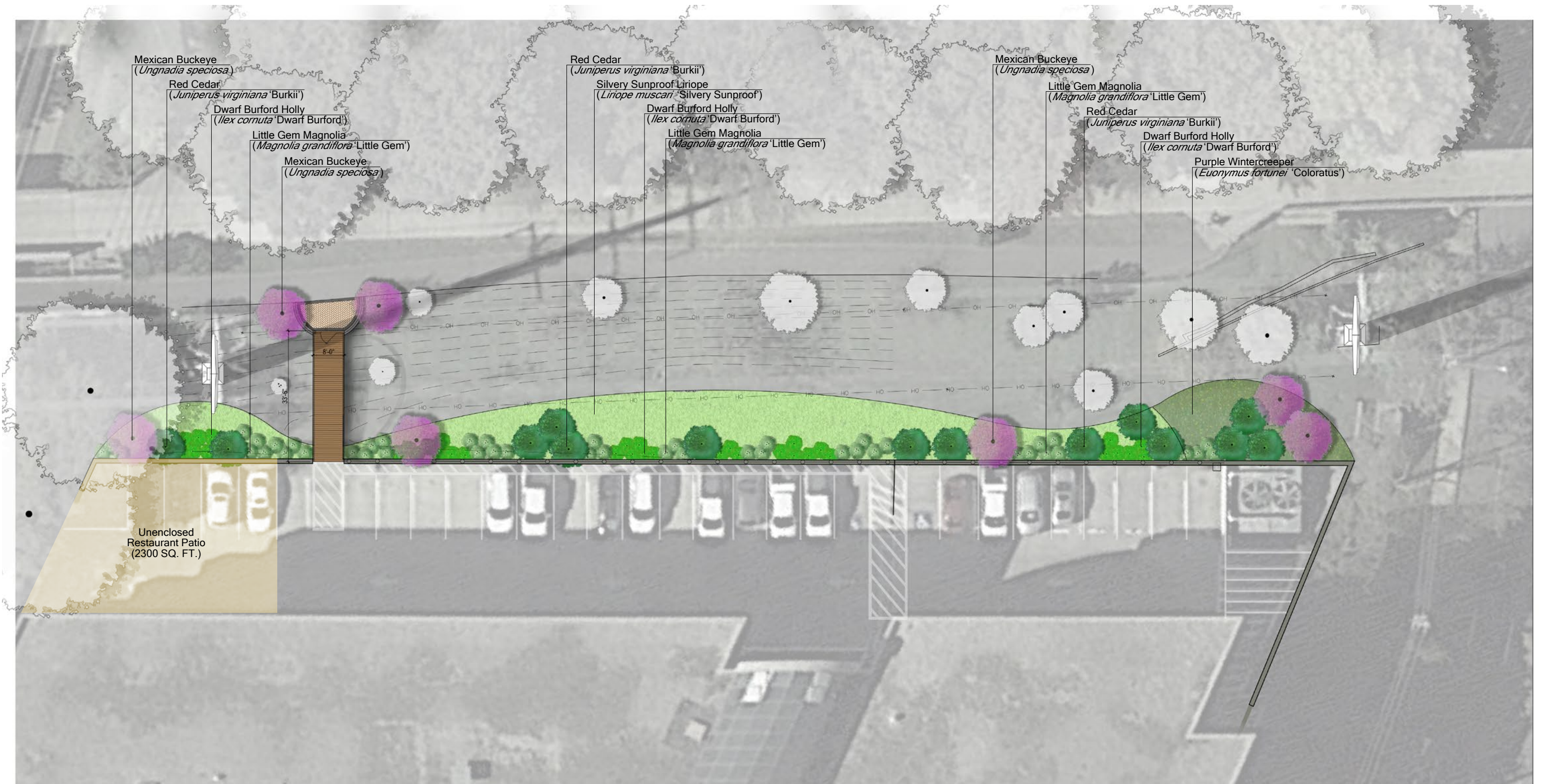

LANDSCAPE PLAN

Katy Trail Connection  
3535 Travis Street, Dallas Texas

Job #: 13296.00  
File Name: Rendered Site Plan.pdf  
Date: 03/23/2016  
Drawn by: AJM

Exhibit A

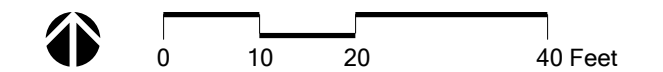

2808 Fairmount Street, Suite 300  
Dallas, Texas 75201 | 214.303.1500

3300 West 7th Street, Suite 110  
Fort Worth, Texas 76107 | 817.303.1500



April 7, 2016

*Katy Trail*  
*3535 Travis St*  
*Development and Maintenance Agreement*

**Exhibit B**

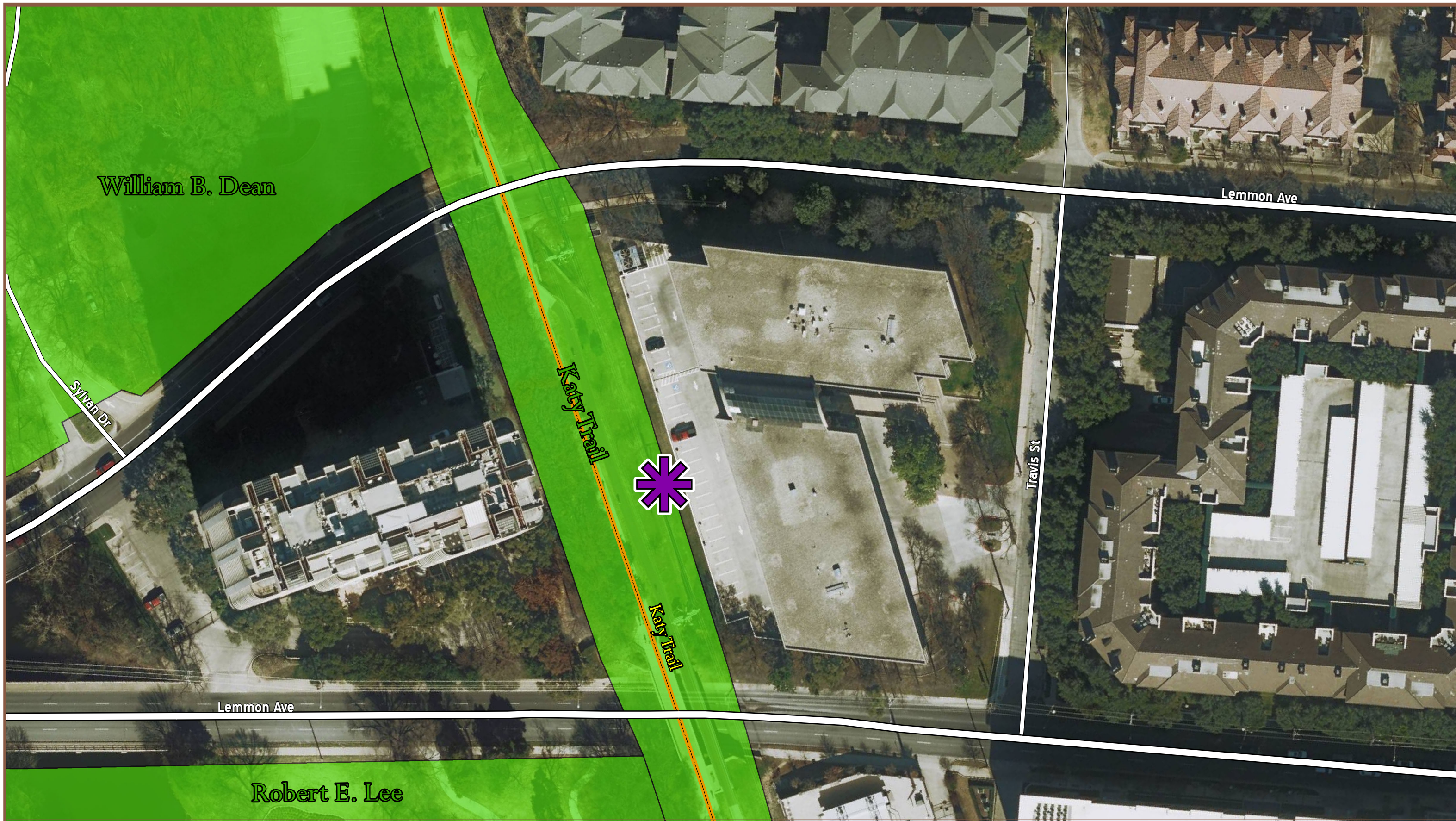

April 7, 2016



Katy Trail  
(3535 Travis St)

Mapsco  
35 X

District  
14



**DALLAS PARK AND RECREATION BOARD  
AGENDA SHEET**

**DATE:** April 7, 2016  
**COUNCIL DISTRICT(S):** 8  
**STAFF:** Louise Elam, 214-670-5275  
**MAPSCO:** 69-H

---

**SUBJECT**

Authorize a public hearing to be held on May 25, 2016 to receive comments on the proposed change of use and sale of a portion of the Kleberg Trail, consisting of a total of approximately 71,109 square feet of land (Exhibits A and B), to the Texas Department of Transportation (TxDOT) for construction of improvements to I-20 Frontage Roads; and at the close of the public hearing, a resolution authorizing the proposed change of use of parkland and sale pursuant to Chapter 26 of the Texas Parks and Wildlife Code - Financing: No cost consideration to the City - Revenue: \$18,365

**BACKGROUND**

The City of Dallas owns municipal parkland known as the Kleberg Trail located southeast of downtown. TxDOT requires a portion of the Kleberg Trail for its I-20 State Highway Improvement Project, Federal Aid Project #STP 1502 (329) MM, for the purpose of extending the frontage road on either side of I-20 south of US Highway 175 (CF Hawn Freeway). TxDOT will pay the fair market value of the parcel as determined by an independent appraisal.

Mayor Tom Leppert, through the Mayor's Southern Dallas Task Force, recommended purchase of approximately 2.2 miles of Union Pacific railroad right-of-way for the Kleberg Trail to encourage and promote economic development opportunities. Despite the rural character of West Kleberg compared to the remainder of Dallas, adjacent communities of Seagoville, Balch Springs, and Mesquite were providing stiff competition for retail and industrial development. The Kleberg Trail was identified as an important opportunity to provide for the development of the area by delivering an alternative transportation route and links to future bus and Park & Ride development and, at that time, the future DART Buckner Green Line Station. Post-development of the Kleberg Trail envisioned additional recreational facilities including soccer fields, a BMX bike trail, golf courses, and other open space amenities. Such development would attract residential and retail development. In 2011 the City purchased the railroad right-of-way for park purposes.

## **BACKGROUND (CONTINUED)**

Over the past months City staff and TxDOT have negotiated terms of the sale which preserve the City's ability to construct a trail of a minimum of sixteen feet, if need be, address safety, and require minimal cost to the City at such time the trail is constructed (Exhibit C). TxDOT agrees as condition of the sale of parkland to:

- 1) Modify box culvert lengths to accommodate the future trail.
- 2) Construct pedestrian ramps at intersections or allow for and accommodate sixteen-foot non-vehicular access to the future trail and install bollards, or allow such devices to impede vehicular access to the parkland until such time that the trail is constructed.
- 3) Revise proposed drainage culvert lengths to accommodate the future trail.
- 4) Provide stop signs or other traffic control devices to provide safe crossing of TxDOT facilities by trail users at the time the trail is constructed.

In compliance with the law, TxDOT has determined that there is a need and that no feasible and prudent alternative exists and that all reasonable care has been taken so as to not damage the remainder of the park property and to mitigate any disruption of current and future park services, including hike and bike trail development.

In accordance with the Texas Parks and Wildlife Code, Chapter 26 (Sections 26.001 through 26.004) the City Council must advertise and hold a public hearing on the change of use of park land.

## **FISCAL INFORMATION**

No cost consideration to the City.

## **PRIOR ACTION/REVIEW (Council, Boards, Commissions)**

This item has no prior action.

The Planning and Design Committee will consider this item on April 7, 2016 and will present a recommendation to the Park and Recreation Board on the same day.

This item will be scheduled for City Council approval on April 27, 2016.

## **ATTACHMENTS**

1. Exhibits
2. Map

Exhibit "A"

County: Dallas  
Parcel: 8  
Highway: Interstate Highway 20  
ROW CSJ: 2374-03-082

Page 1 of 5  
August 2014

**LEGAL DESCRIPTION FOR PARCEL 8**

BEING a 1.6324 acre tract of land situated in the Solomon Dixon Survey, Abstract Number 407 in the City of Dallas, Dallas County, Texas, Official City of Dallas Block Numbers 8765, 8766, 8790, 8794 and being a part of a called 5.253 acre tract of land described as Kleberg Trail Corridor Parcel 5 in Donative Deed without Warranty to the City of Dallas, as recorded in Instrument Number 201100327219 of the Official Public Records of Dallas County, Texas (O.P.R.D.C.T.), and being more particularly described as follows:

COMMENCING at a point on the northeast line of said 5.253 acre tract for the south corner of a called 1.6173 acre tract of land described in Warranty Deed to RJC Theaters, LLC, as recorded in Instrument Number 200503570214, O.P.R.D.C.T. and the southwest corner of a called 5.7147 acre tract of land described in Special Warranty Deed with Vendor's Lien to RJC Theatres, LLC, as recorded in Volume 2005083, Page 05877, O.P.R.D.C.T. having NAD83 (2011 Adjustment) Texas State Plane North Central Zone (4202) surface coordinates North 6,939,137.63 feet, East 2,543,295.28 feet, from which a 1/2-inch found iron rod for witness bears North 68 degrees 34 minutes 42 seconds East a distance of 0.63 of a foot;

THENCE North 53 degrees 37 minutes 54 seconds West, with the northeast line of said 5.253 acre tract and with the southwest line of said 1.6173 acre tract, a distance of 290.50 feet to a 5/8-inch set iron rod with a TxDOT aluminum cap having NAD83 (2011 Adjustment) Texas State Plane North Central Zone (4202) surface coordinates North 6,939,309.89 feet, East 2,543,061.36 feet for the POINT OF BEGINNING, said point being on the proposed southerly right-of-way line of Interstate Highway 20 (a variable width right-of-way) for the point of curvature of a non-tangent circular curve to the right having a radius of 1,000.00 feet and a chord that bears South 42 degrees 42 minutes 59 seconds West a distance of 100.62 feet; \*\*

- 1) THENCE Southwesterly, departing the northeast line of said 5.253 acre tract and the southwest line of said 1.6173 acre tract, over and across said 5.253 acre tract, and with the proposed southerly right-of-way line of said Interstate Highway 20 and with said curve, through a central angle of 05 degrees 46 minutes 02 seconds, an arc distance of 100.66 feet to a 1/2-inch set iron rod with a yellow plastic cap stamped "HALFF" on the southwest line of said 5.253 acre tract and the northeast line of a called 5.45 acre tract of land described in Warranty Deed to Matthew Millard, as described in Instrument Number 200503553505, O.P.R.D.C.T. for the end of said curve;



Exhibit "A"

County: Dallas  
Parcel: 8  
Highway: Interstate Highway 20  
ROW CSJ: 2374-03-082

Page 2 of 5  
August 2014

- 2) THENCE North 53 degrees 37 minutes 54 seconds West, with the southwest line of said 5.253 acre tract and with the northeast line of said 5.45 acre tract, passing the north corner of said 5.45 acre tract on the existing south right-of-way line of said Interstate Highway 20 (a variable width right-of-way) at a distance of 86.56 feet, continuing with the southwest line of said 5.253 acre tract and over and across said Interstate Highway 20, in all, a total distance of 715.77 feet to a 5/8-inch set iron rod with a TxDOT aluminum cap at the intersection of the proposed northerly right-of-way line of said Interstate Highway 20 with the existing north right-of-way line of said Interstate Highway 20 for corner; \*\*
- 3) ~~THENCE North 48 degrees 52 minutes 44 seconds East, departing the southwest line of said 5.253 acre tract, over and across said 5.253 acre tract, and with the proposed northerly right-of-way line of said Interstate Highway 20, a distance of 102.43 feet to a 5/8-inch set iron rod with a TxDOT aluminum cap on the northeast line of said 5.253 acre tract and the southwest line of a called 1.6208 acre tract of land described in Special Warranty Deed with Vendor's Lien to Martin Brena, Jr. and Alvaro Brena, as recorded in Instrument No. 20080312211, O.P.R.D.C.T., and Affidavit, as recorded in Instrument No. 200900190950, O.P.R.D.C.T. for corner; \*\*~~
- 4) THENCE South 53 degrees 37 minutes 54 seconds East, departing the proposed northerly right-of-way line of said Interstate Highway 20, with the northeast line of said 5.253 acre tract and with the southwest line of said 1.6208 acre tract, passing the south corner of said 1.6208 acre tract on the existing north right-of-way line of said Interstate Highway 20 at a distance of 37.82 feet, continuing with the northeast line of said 5.253 acre tract and over and across said Interstate Highway 20, passing the west corner of a called 1,353 square foot tract of land described in Warranty Deed to Thomas E. Hendricks and Linda E. Hendricks, as recorded in Instrument Number 201100089453, O.P.R.D.C.T. on the existing south right-of-way line of said Interstate Highway 20 at cumulative distance of 657.72, continuing with the northeast line of said 5.253 acre tract and with the southwest line of said 1,353 square foot tract, passing the south corner of said 1,353 square foot tract and the southwest corner of said 1.6173 acre tract at a cumulative distance of 702.86 feet, continuing with the northeast line of said 5.253 acre tract and with the southwest line of said 1.6173 acre tract, in all, a total distance of 704.71 feet the POINT OF BEGINNING AND CONTAINING 71,109 square feet or 1.6324 acres of land, more or less.

Exhibit "A"

County: Dallas  
Parcel: 8  
Highway: Interstate Highway 20  
ROW CSJ: 2374-03-082

Page 3 of 5  
August 2014

\*\* The monument described and set may be replaced with a TxDOT Type II right-of-way marker upon the completion of the construction project, under the supervision of a RPLS, either employed or retained by the State.

The Basis of Bearing is the North American Datum of 1983, Texas State Plane Coordinate System, North Central Zone 4202. All distances are surface distances. Surface Adjustment Scale Factor: 1.0001365060.

I, Heath W. Brown, a Registered Professional Land Surveyor, hereby certify that the legal description hereon and the accompanying plat of even date represent an actual survey made on the ground under my supervision.

Heath 8-1-2014

Heath W. Brown  
Registered Professional Land Surveyor  
Texas No. 6189  
Halff Associates, Inc.,  
1201 North Bowser Rd.  
Richardson, Texas 75081  
TBPLS Firm No. 10029600



EXHIBIT "A"  
PARCEL 8

GRAPHIC SCALE

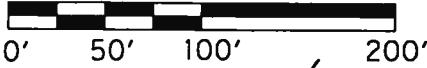

(CALLED 1.806 ACRES)  
PARCEL 24  
STATE OF TEXAS  
VOL. 67195, PG. 2144  
D.R.D.C.T.

INTERSTATE HIGHWAY 20  
(VARIABLE WIDTH R.O.W.)

EXISTING  
R.O.W.  
LINE

BLOCK 8790  
UNPLATTED

(CALLED 1.673 ACRES)  
RJC THEATERS, LLC  
INSTR. NO. 200503570214  
O.P.R.D.C.T.

(CALLED 5.7147 ACRES)  
RJC THEATERS, LLC  
VOL. 2005083, PG. 05877  
O.P.R.D.C.T.

FND, TXDOT  
MON.  
(MISSING DISK)

(CALLED 85,706  
SQUARE FEET)  
PARCEL 20  
STATE OF TEXAS  
VOL. 195, PG. 0166  
D.R.D.C.T.

(CALLED 1,353 SQUARE FEET)  
THOMAS E. HENDRICKS AND  
LINDA E. HENDRICKS  
INSTR. NO. 201100089453  
O.P.R.D.C.T.

POINT OF BEGINNING  
N=6,939,309.89  
E=2,543,061.36  
STA. 220+00.00  
372.42' RT \*\*

$\Delta=05^{\circ}46'02''\text{RT}$   
 $R=1,000.00'$   
 $L=100.66'$   
 $CL=100.62'$   
 $CB=S42^{\circ}42'59''\text{W}$

MATCHLINE  
SEE SHEET 5

8

71,109 SQ. FT.  
OR  
1.6324 ACRE

(CALLED 4.913 ACRES)  
PARCEL 45  
STATE OF TEXAS  
CAUSE NO. CC-67-1066-b  
THE COUNTY COURT OF DALLAS  
COUNTY AT LAW NO. 2,  
DALLAS COUNTY, TEXAS  
VOL. 67066, PG. 0910  
D.R.D.C.T.

EXISTING  
R.O.W. LINE  
AND ACCESS  
DENIAL LINE

(CALLED 5.45 ACRES)  
MATTHEW MILLARD  
INSTR. NO. 200503553505  
O.P.R.D.C.T.

BLOCK 8790  
UNPLATTED

SOLOMON DIXON SURVEY  
ABSTRACT NUMBER 407

POINT OF COMMENCING  
N=6,939,137.63  
E=2,543,295.28

1/2" FIR W/  
"HALFF ASSOC INC."  
CAP BEARS N89° 29' 55" W 1.56'

A PLAT OF A SURVEY OF  
A 71,109 SQ. FT. TRACT OF LAND  
IN THE SOLOMON DIXON SURVEY  
ABSTRACT NUMBER 407  
DALLAS COUNTY, TEXAS

The Basis of Bearing is the North  
American Datum of 1983, Texas State  
Plane Coordinate System, North Central  
Zone 4202. All distances are surface  
distances. Surface Adjustment Scale  
Factor: 1.0001365060.

AUGUST 2014  
DATE

4/5

8/1/2014 10:42:43 AM 012481 TX08X23000s\23731\W006\CADD\Sheets RCH\VEKH-008-PG1-W006-23731.DGN

**LEGEND**

EXISTING RIGHT OF WAY LINE	—————
PROPOSED RIGHT OF WAY LINE	—————
PROPOSED BASELINE	—————
PROPERTY LINE	—————
COUNTY LINE	—————
ACCESS DENIAL LINE	—————
ACCESS IS PROHIBITED ACROSS THE ACCESS DENIAL LINE	—————
SURVEY LINE	—————
FENCE LINE	—x—x—
CITY LIMITS	—————
EASEMENTS	—————
RAILROAD	—————
STRUCTURE	—————
FIR = FOUND IRON ROD	
FIP = FOUND IRON PIPE	
(C.M.) = CONTROL MONUMENT	
INSTR. NO. = INSTRUMENT NUMBER	
MON. = MONUMENT	
○ = 1/2-INCH SET IRON ROD WITH YELLOW PLASTIC CAP STAMPED "HALFF" (UNLESS NOTED)	
◻ = 5/8-INCH IRON ROD WITH TXDOT ALUMINUM CAP	
● = FOUND MONUMENT (AS NOTED)	

\*\* THE MONUMENT DESCRIBED AND SET MAY BE REPLACED WITH A TXDOT TYPE RIGHT-OF-WAY MARKER UPON THE COMPLETION OF THE CONSTRUCTION PROJECT UNDER THE SUPERVISION OF A RPLS, EITHER EMPLOYED OR RETAINED BY THE STATE.

EXHIBIT "A"  
PARCEL 8

GRAPHIC SCALE



SOLOMON DIXON SURVEY  
ABSTRACT NUMBER 407

BLOCK 8767  
UNPLATTED

EXISTING  
R.O.W. LINE

(CALLED 1.6208 ACRES)  
MARTIN BRENA, JR.  
AND ALVARO BRENA  
INSTR. NO. 20080312211  
INSTR. NO. 200900190950  
O.P.R.D.C.T.

(REMAINDER OF  
CALLED 1.65773 ACRES)  
MARY ELIZABETH KALLAUS  
VOL. 89097, PG. 3060  
D.R.D.C.T.

(CALLED 1.941 ACRES)  
PARCEL 26  
STATE OF TEXAS  
VOL. 377, PG. 1231  
D.R.D.C.T.

INTERSTATE  
HIGHWAY 20  
(VARIABLE WIDTH R.O.W.)

PROPOSED  
R.O.W. LINE

STA. 218+99.88  
325.16' LT \*\*

71,109 SQ. FT.  
OR  
1.6324 ACRE

FND.  
PK-NAIL  
W/ "HALFF"  
WASHER

(CALLED 0.95 ACRES)  
PORTION OF ABANDONED  
SEWELL CIRCLE  
VINCENT SEWELL  
VOL. 70155, PG. 0798  
D.R.D.C.T.

BLOCK 8766  
UNPLATTED

(CALLED 2.674 ACRES)  
TRACT NO. 1  
CAMERON DEE SEWELL,  
TRUSTEE OF THE WILLIAM  
A. SEWELL REVOCABLE TRUST  
VOL. 87053, PG. 4616  
D.R.D.C.T.

STA. 217+80.85  
327.86' LT \*\*

EXISTING  
R.O.W. LINE  
AND  
ACCESS  
DENIAL LINE

(CALLED 4.913 ACRES)  
PARCEL 45  
STATE OF TEXAS  
CAUSE NO. CC-67-1066-b  
THE COUNTY COURT OF DALLAS  
COUNTY AT LAW NO. 2,  
DALLAS COUNTY, TEXAS  
VOL. 67066, PG. 0910  
D.R.D.C.T.

SEWELL CIRCLE  
(60' WIDE R.O.W.)  
VOL. 4071, PG. 296  
D.R.D.C.T.

INTERSTATE  
HIGHWAY 20  
(VARIABLE WIDTH R.O.W.)

MATCHLINE,  
SEE SHEET 4



A PLAT OF A SURVEY OF  
A 71,109 SQ. FT. TRACT OF LAND  
IN THE SOLOMON DIXON SURVEY  
ABSTRACT NUMBER 407  
DALLAS COUNTY, TEXAS

HEREBY CERTIFY THAT THIS PLAT  
IS BASED ON AN ON THE GROUND SURVEY  
MADE UNDER MY SUPERVISION AND,  
TO THE BEST OF MY KNOWLEDGE,  
IS TRUE AND CORRECT.

Heath W. Brown 8-1-2014  
HEATH W. BROWN, R.P.L.S. TEXAS No. 6189

AUGUST 2014  
DATE

5/5

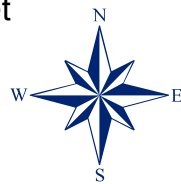
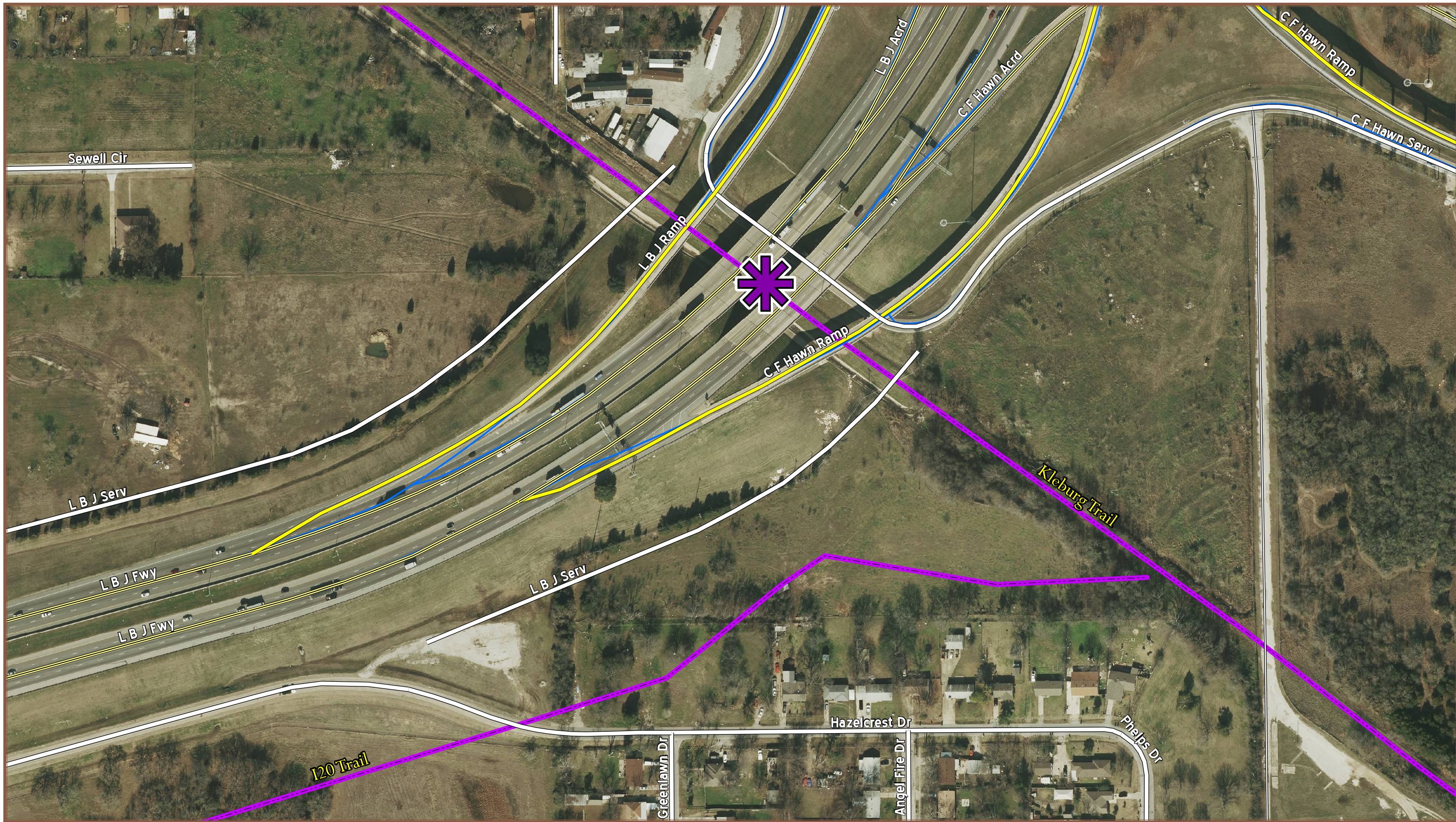

April 7, 2016

# Kleberg Trail (I-20 and US Hwy 175 Southbound Frontage Rd) Exhibit B

Mapsc0  
69 H

District  
8



PRELIMINARY

FOR INTERIM REVIEW ONLY

THESE DOCUMENTS ARE FOR INTERIM REVIEW AND NOT INTENDED FOR REGULATORY APPROVAL, PERMIT, BIDDING OR CONSTRUCTION PURPOSES. THEY WERE PREPARED BY OR UNDER THE SUPERVISION OF:

JEREMY W. MCGAHAN 183658 03/08/2015  
NAME P.E. NO. DATE

FIRM REGISTRATION NUMBER: 312

# REVISED TRAIL ACCOMMODATIONS

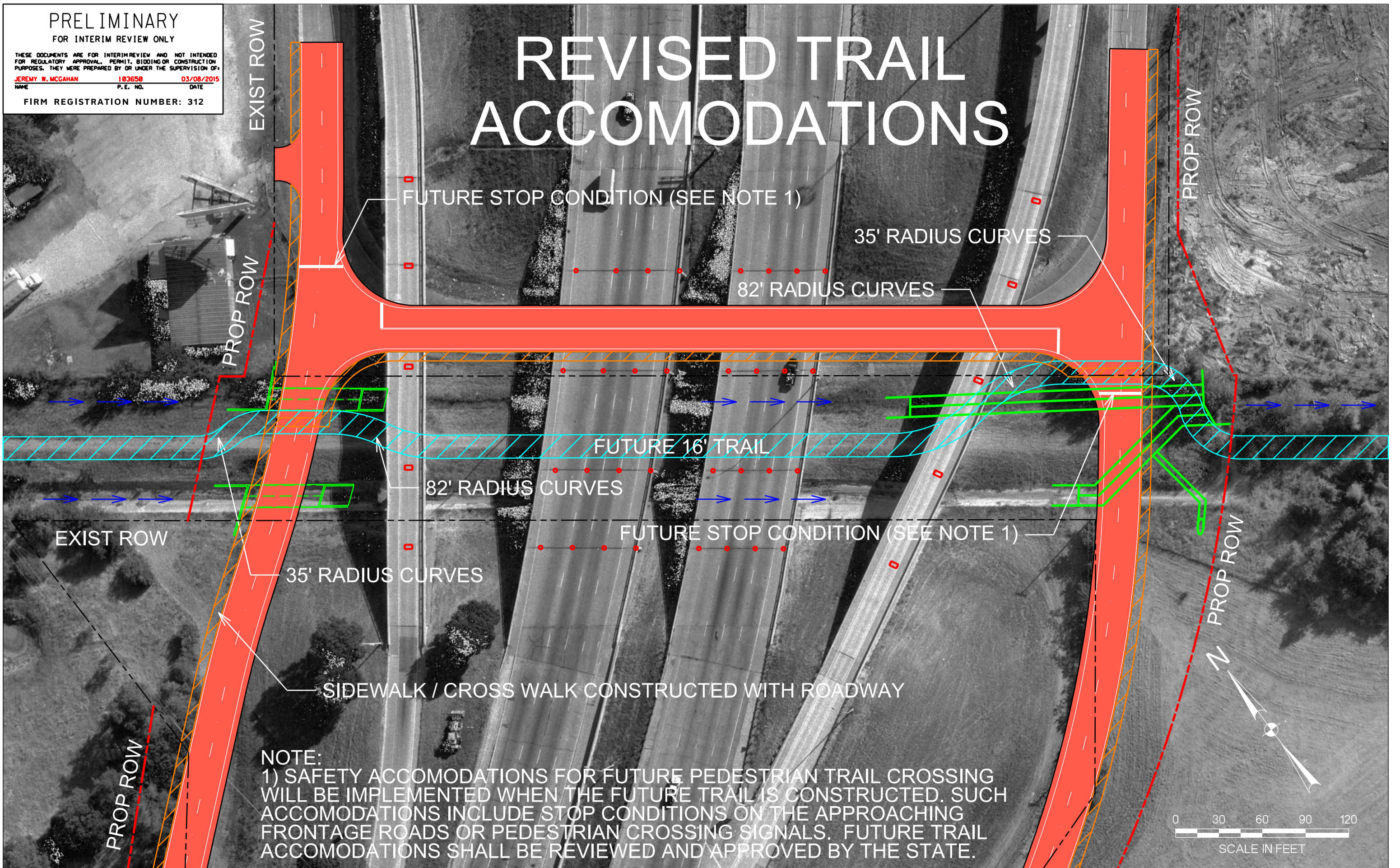

NOTE:  
1) SAFETY ACCOMODATIONS FOR FUTURE PEDESTRIAN TRAIL CROSSING WILL BE IMPLEMENTED WHEN THE FUTURE TRAIL IS CONSTRUCTED. SUCH ACCOMODATIONS INCLUDE STOP CONDITIONS ON THE APPROACHING FRONTAGE ROADS OR PEDESTRIAN CROSSING SIGNALS. FUTURE TRAIL ACCOMODATIONS SHALL BE REVIEWED AND APPROVED BY THE STATE.

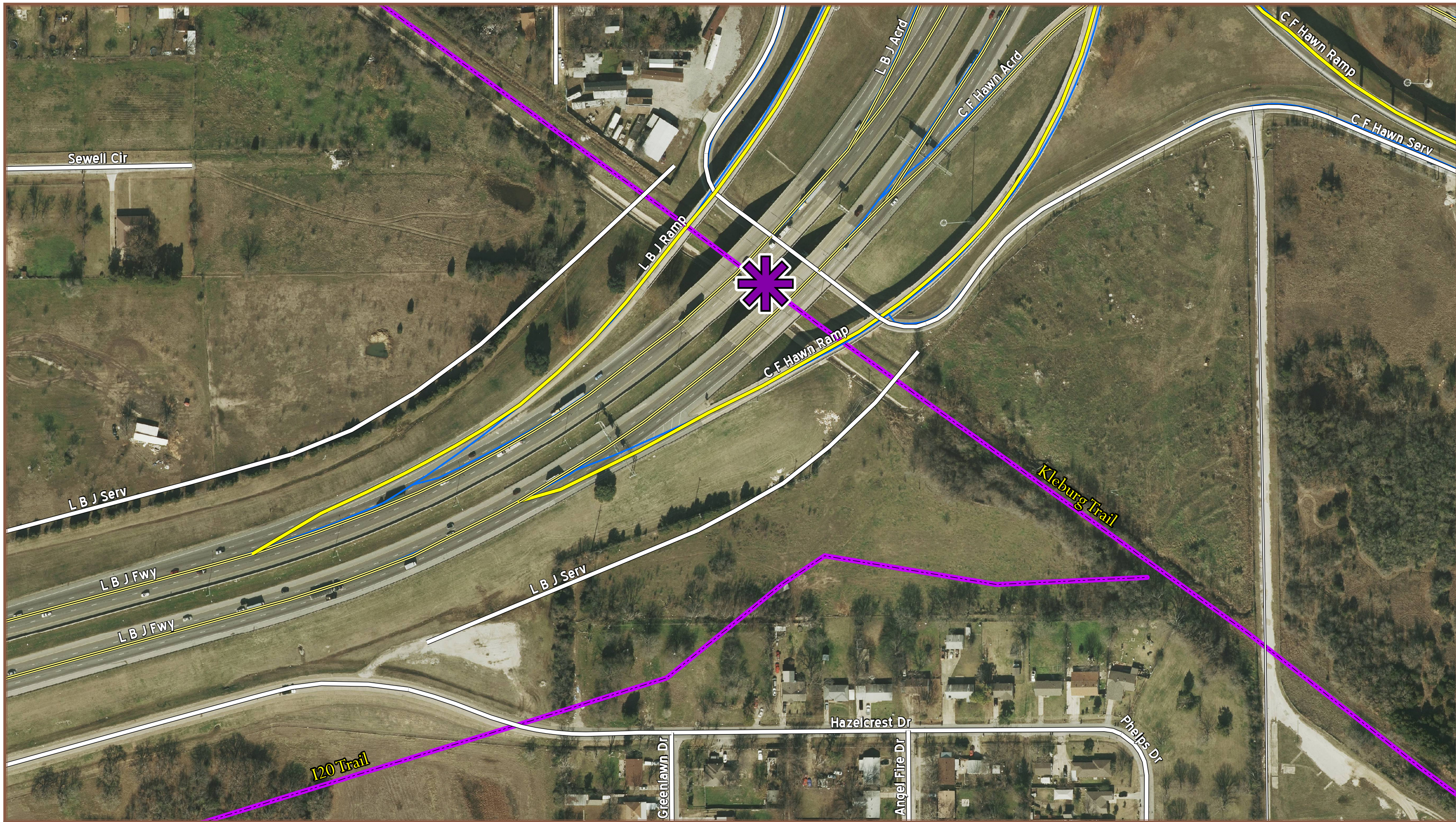

April 7, 2016

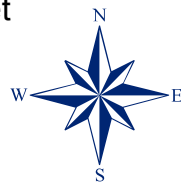

# Kleberg Trail (I-20 and US Hwy 175 Southbound Frontage Rd)

Mapscop  
69 H

District  
8

**KEY FOCUS AREA:** Culture, Arts and Recreation and Educational Enhancements

**AGENDA DATE:** April 27, 2016

**COUNCIL DISTRICT(S):** 5

**DEPARTMENT:** Park & Recreation

**CMO:** Louise Elam, 214-670-5275

**MAPSCO:** 48-P

---

### **SUBJECT**

Authorize **(1)** the receipt and deposit of funds in the amount of \$70,000 in the Capital Gifts, Donation and Development Fund; **(2)** the establishment of appropriations in the Capital Gifts, Donation and Development Fund in the amount of \$70,000; and **(3)** the acceptance of Memorandum of Understanding (MOU) from the National Recreation and Park Association (NRPA) for a new playground equipment at Urbandale Park located at 7400 Ireland Avenue - Not to exceed \$70,000 - Financing: Capital Gifts, Donation and Development Funds

### **BACKGROUND**

The NRPA is offering financial assistance for park renovation projects through support by Niagara Bottling. Staff identified the renovation of Urbandale Park playground for receipt of this grant. The playground in this park was vandalized approximately ten years ago and has not been replaced. The grant will provide funds to replace the playground equipment. Equipment will be installed by Park and Recreation Department staff.

The MOU will be subject to the following terms:

1. The project be completed by May 31, 2016 or a mutually agreed date.
2. Provide for an opportunity for recognition of Niagara Bottling during a celebration event and install signage recognizing Niagara Bottling's donation.
3. Permit NRPA and Niagara Bottling use of the Park and Recreation Department's name, photos, and information in connection with the project for promotional and other purposes associated with the grant.

## **ESTIMATED SCHEDULE OF PROJECT**

Begin Construction      April 2016  
Complete Construction    May 2016

## **PRIOR ACTION/REVIEW (COUNCIL, BOARDS, COMMISSIONS)**

This item has no prior action.

The Planning and Design Committee will consider this item on April 7, 2016 and will present a recommendation to the Park and Recreation Board on the same day.

This item will be scheduled for City Council approval on April 27, 2016.

## **FISCAL INFORMATION**

Capital Gifts, Donation and Development Funds - \$70,000

## **MAP**

Attached

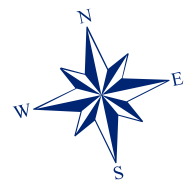

April 7, 2016

# Urbandale Park (7400 Ireland Ave)

Mapsco  
48 P

District  
5

**KEY FOCUS AREA:** Culture, Arts and Recreation and Educational Enhancements

**AGENDA DATE:** April 27, 2016

**COUNCIL DISTRICT(S):** 3, 8

**DEPARTMENT:** Park & Recreation

**CMO:** Louise Elam, 214-670-5275

**MAPSCO:** 65-K, L, Q, U, X, Y, 75-B

---

**SUBJECT**

Authorize a contract for trail improvements at Runyon Creek Trail located between Glendale Park to Camp Wisdom Road – Northstar Construction, LLC, lowest responsible bidder of two – Not to exceed \$2,497,700 – Financing: General Obligation Commercial Paper Funds (PKR-2016-00000386)

**BACKGROUND**

On February 12, 2016, two bids were received for trail improvements at Runyon Creek Trail. This item authorizes award of the construction contract to Northstar Construction, LLC for the Base Bid and Alternate Nos. 1 and 4, with a total contract amount of \$2,497,700. The trail is 14 feet wide and will extend from Glendale Park to Camp Wisdom Road.

The following chart illustrates Northstar Construction, LLC's contractual activities with the City of Dallas for the past three years:

	<u>PWT</u>	<u>DWU</u>	<u>PKR</u>
Projects Completed	0	0	2
Change Orders	0	0	3
Projects Requiring Liquidated Damages	0	0	0
Projects Completed by Bonding Company	0	0	0

It is anticipated that this project will require operating and maintenance funding in the amount of \$32,797 annually.

**ESTIMATED SCHEDULE OF PROJECT**

Began Design                      January 2014  
Completed Design                August 2015  
Begin Construction                April 2016  
Complete Construction          May 2017

**PRIOR ACTION/REVIEW (COUNCIL, BOARDS, COMMISSIONS)**

The Park and Recreation Board authorized advertisement for bids on August 6, 2015.

The Park and Recreation Board deferred this item on March 10, 2016.

The Planning and Design Committee will consider this item on April 7, 2016 and will present a recommendation to the Park and Recreation Board on the same day.

This item is scheduled for City Council approval on April 27, 2016.

**FISCAL INFORMATION**

2012 Bond Program (General Obligation Commercial Paper Funds) - \$2,497,700

<u>Council District</u>	<u>Amount</u>
3	\$1,363,630
8	<u>\$1,134,070</u>
Total	\$2,497,700

**M/WBE INFORMATION**

See attached.

**ETHNIC COMPOSITION**

Northstar Construction, LLC

White Male	4	White Female	0
Black Male	0	Black Female	0
Hispanic Male	12	Hispanic Female	1
Other Male	0	Other Female	0

**BID INFORMATION**

The following two bids were received and opened on February 12, 2016:

\*Denotes the successful bidder

<b><u>Bidders</u></b>	<b><u>Base Bid</u></b>	<b><u>Alter. Nos. 1 &amp; 4**</u></b>	<b><u>Total Bid</u></b>
*Northstar Construction, LLC 2112 Solona Street Fort Worth, Texas 76117	\$1,994,700	\$503,000	\$2,497,700
The Fain Group, Inc.	\$2,228,727	\$716,742	\$2,945,469

\*\*Alternate No. 1 - provides for installation of ramp and inner loop modifications north of Glendale Park.

\*\*Alternate No. 4 - provides for installation of overlook.

**OWNER**

**Northstar Construction, LLC**

Michael A. Heimlich, President

**MAP**

Attached



**Anastacio, Vhee**

---

**From:** Williams, Regina T.  
**Sent:** Monday, March 21, 2016 1:20 PM  
**To:** Anastacio, Vhee  
**Cc:** Parker, Lisa  
**Subject:** FW: BID APPROVAL NORTHSTAR CONSTRUCTION RUNYON CREEK GREENBELT TRAIL 21.74

## **BUSINESS INCLUSION AND DEVELOPMENT PLAN SUMMARY**

**PROJECT:** Authorize a contract for trail improvements at Runyon Creek Trail located between Glendale Park to Camp Wisdom Road – Northstar Construction, LLC, lowest responsible bidder of two – Not to exceed \$2,497,700 – Financing: General Obligation Commercial Paper Funds (PKR-2016-00000386)

Northstar Construction, LLC is a local, minority firm, has signed the "Business Inclusion & Development" documentation, and proposes to use the following sub-contractors.

**PROJECT CATEGORY:** Construction

### LOCAL/NON-LOCAL CONTRACT SUMMARY

	<u>Amount</u>	<u>Percent</u>
Total local contracts	\$117,990.00	4.72%
Total non-local contracts	\$2,379,710.00	95.28%
<b>TOTAL CONTRACT</b>	<b>\$2,497,700.00</b>	<b>100.00%</b>

### LOCAL/NON-LOCAL M/WBE PARTICIPATION

#### Local Contractors / Sub-Contractors

<u>Local</u>	<u>Certification</u>	<u>Amount</u>	<u>Percent</u>
Logan Trucking	BMMB63584N1116	\$15,000.00	12.71%
Garcia Land Data Inc.	HMMB64109N0217	\$15,000.00	12.71%
CT & S Metalworks	WFDB68320Y1016	\$87,990.00	74.57%
<b>Total Minority - Local</b>		<b>\$117,990.00</b>	<b>100.00%</b>

#### Non-Local Contractors / Sub-Contractors

<u>Non-local</u>	<u>Certification</u>	<u>Amount</u>	<u>Percent</u>
Martinez Construction Services dba MCS	HMDB51622Y0616	\$127,040.00	5.34%
Cowtown RediMix	WFWB06682Y0916	\$197,300.00	8.29%
GJ Seeding, LLC	WFWB4101N0417	\$48,585.00	2.04%
Acme Fence Services, Inc.	WFWB62100N0616	\$19,200.00	0.81%
LB Transportation Operations	WFWB63913Y0117	\$18,000.00	0.76%
Richochet Fuel Distributions	WFWB63913Y0117	\$15,000.00	0.63%
<b>Total Minority - Non-local</b>		<b>\$425,125.00</b>	<b>17.86%</b>

**TOTAL M/WBE CONTRACT PARTICIPATION**

	<b><u>Local</u></b>	<b><u>Percent</u></b>	<b><u>Local &amp; Non-Local</u></b>	<b><u>Percent</u></b>
African American	\$15,000.00	12.71%	\$15,000.00	0.60%
Hispanic American	\$15,000.00	12.71%	\$142,040.00	5.69%
Asian American	\$0.00	0.00%	\$0.00	0.00%
Native American	\$0.00	0.00%	\$0.00	0.00%
WBE	\$87,990.00	74.57%	\$386,075.00	15.46%
Total	<u>\$117,990.00</u>	<u>100.00%</u>	<u>\$543,115.00</u>	<u>21.74%</u>



21-75

CITY OF DALLAS  
CONTRACTOR'S AFFIDAVIT  
SCHEDULE OF WORK AND ACTUAL PAYMENT FORM

REVISED

Project Name: Runyon Creek Greenbelt Trail

Bid/Contract #: \_\_\_\_\_

Instructions:

Column 1: List type of work to be performed by Prime and 1st tier subcontractors.

Column 2: City of Dallas Vendor Number for Prime and Subcontractors/Suppliers (if none, register online: www.bids.dallascityhall.org). ALL Prime and Subcontractors/Suppliers must be registered with the City of Dallas

Column 3: List name of firm; M/WBE Certification Number (if applicable).

Column 4: List firm(s), contact name; address; telephone number.

Column 5: List ethnicity of firm(s) owner as B=African American, H=Hispanic, I=Asian Indian; N=Native American; P=Asian Pacific, W=Woman; NON=other than M/WBE.

Column 6: Indicate firm's location as L=local (within Dallas county limits); N=Non-local (Outside Dallas county limits).

Column 7: Indicate dollar amount of value of work for the Prime contractor, subcontractors, and suppliers.

Column 8: Indicate percentage of total contract amount.

Column 9: Indicate total payments to date

Column 10: Indicate payments during current pay period.

Type of Work [1]	City of Dallas Vendor Number [2]	Name of Firm & M/WBE Certification (If Applicable) [3]	Contact Name Address, City, State, Zip & Tel. Number [4]	Type of Firm [5]	L or N [6]	Value of Work (\$) [7]	Percent (%) [8]	Payments to Date (\$) [9]	Payment this Period (\$) [10]
Surveying		Garcia Land Data, Inc. HMMB64109N0217	Ernie Garcia 6210 Campbell Rd. Ste.110 Dallas, TX 75248 214-987-0149	H	L	\$ 15,000.00	0.60%		
Notes:									
Rebar, Concrete Acc. And Masonry		Martinez Construction Services dba MCS HMDB51622Y0616	Ruben Martinez 836 Big Sky Lane Ft. Worth, TX 76131 817-975-8641	H	N	\$ 127,040.00	5.09%		
Notes:									
Rock, Sand		L.B. Transportation Operations WFWB63913Y0117	Lauren Burton Munro P.O. Box 1016 Keller, TX 76244 817-337-6830	W	N	\$ 18,000.00	0.72%		
Notes:									
Guardrail		CT & S Metalworks WFDB68320Y1016	Janet Witter 1513 Maryland Dr. Irving, TX 75061 972-554-9629	W	N	\$ 87,990.00	3.52%		
Notes:									
Haul Off Concrete, Wood		Logan Trucking BMMB63584N1116	Jack Logan 8624 Marigold Dr. Dallas, TX 75241 214-908-1080	B	L	\$ 15,000.00	0.60%		
Notes:									

Type of Work	City of Dallas Vendor Number	Name of Firm & M/WBE Certification (If Applicable)	Contact Name Address, City, State, Zip & Tel. Number	Type of Firm	L or N	Value of Work (\$)	Percent (%)	Payments to Date (\$)	Payment this Period (\$)
Fuel		Ricochet Fuel Distributors WFWB63913Y0117	Sam Brett 1201 Royal Parkway Euless, TX 76040 817-268-5910	W	N	\$ 15,000.00	0.60%		
Notes:									
Grass Establishment		G J Seeding, LLC WFWB85202H0417	Gayle Juraschek 1080 S. Burleson Blvd. Burleson, TX 76028 817-426-8284	W	N	\$ 48,585.00	1.95%		
Notes:									
Flexamat Recyclex Backing / Erosion Control Mat.		Hill Country Site Supply WFDB64207Y0216	Jennifer Ryan P.O. Box 342468 Austin, TX 78734 972-241-6003	W	N	\$ 30,000.00	1.20%		
Notes: Pending									
Ready Mix Concrete		Cowtown RediMix WFWB06682Y0916	Max Ulrich P.O. Box 162327 Ft. Worth, TX 76161 817-759-1919	W	N	\$ 197,300.00	7.90%		
Notes:									
Temp. Shoring		Oscar Orduno, Inc. HMDB63996Y0116	Chris Robertson 4500 Fuller Drive, Suite 205 Irving, TX 75038 972-717-3070	H	N	\$ 51,391.00	2.06%		
Notes: pending waiting on new certification (DBP)									
Temp. Fencing		Acme Fence Services, Inc. WFWB62100N0616	John Davis 2509 Minnis Dr. Fort Worth, TX 76117 817-831-8880	W	N	\$ 19,200.00	0.77%		
Notes:									
Ready Mix Concrete		Redi-Mix Concrete	Andy Beason 331 N. Main St. Euless, TX 76039 817-835-4000	NON	N	\$ 229,200.00	9.18%		
Notes:									
Pier Drilling		Jerry's Pier Drilling	Jerry 1208 Irwin Dr. Hurst, TX 76053 817-589-2739	NON	N	\$ 27,972.00	1.12%		
Notes:									

3.26  
25.01

Type of Work	City of Dallas Vendor Number	Name of Firm & MWBE Certification (If Applicable)	Contact Name Address, City, State, Zip & Tel. Number	Type of Firm	L or N	Value of Work (\$)	Percent (%)	Payments to Date (\$)	Payment this Period (\$)
General Contractor	VS0000060205	Northstar Construction, LLC	Michael A. Heimlich 2112 Solona Street Fort Worth, TX 76117 817-244-8885	NON	N	\$ 1,616,022.00	64.70%		

Notes: *Northstar Construction to self perform majority of work*

[Note: Totals and Percentages will automatically calculate.]

<b>Total Bid Amount:</b>	<b>\$ 2,497,700.00</b>	<b>100.00%</b>	<b>\$ -</b>	<b>\$ -</b>
--------------------------	------------------------	----------------	-------------	-------------

The undersigned intends to enter into a formal agreement with the subcontractors listed, conditioned upon being awarded the City of Dallas contract. If any changes are made to this list, the Prime contractor must submit to the City for approval a revised schedule with documented explanations for the changes. Failure to comply with this provision could result in termination of the contract, sanctions against the Prime contractor, and/or ineligibility for future City contracts.

Officer's Signature:

*Michael A. Heimlich*

Title: President

Printed Name:

Michael A. Heimlich

Date: March 8, 2016

Company Name:

Northstar Construction, LLC

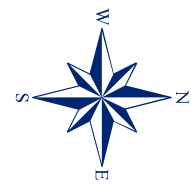
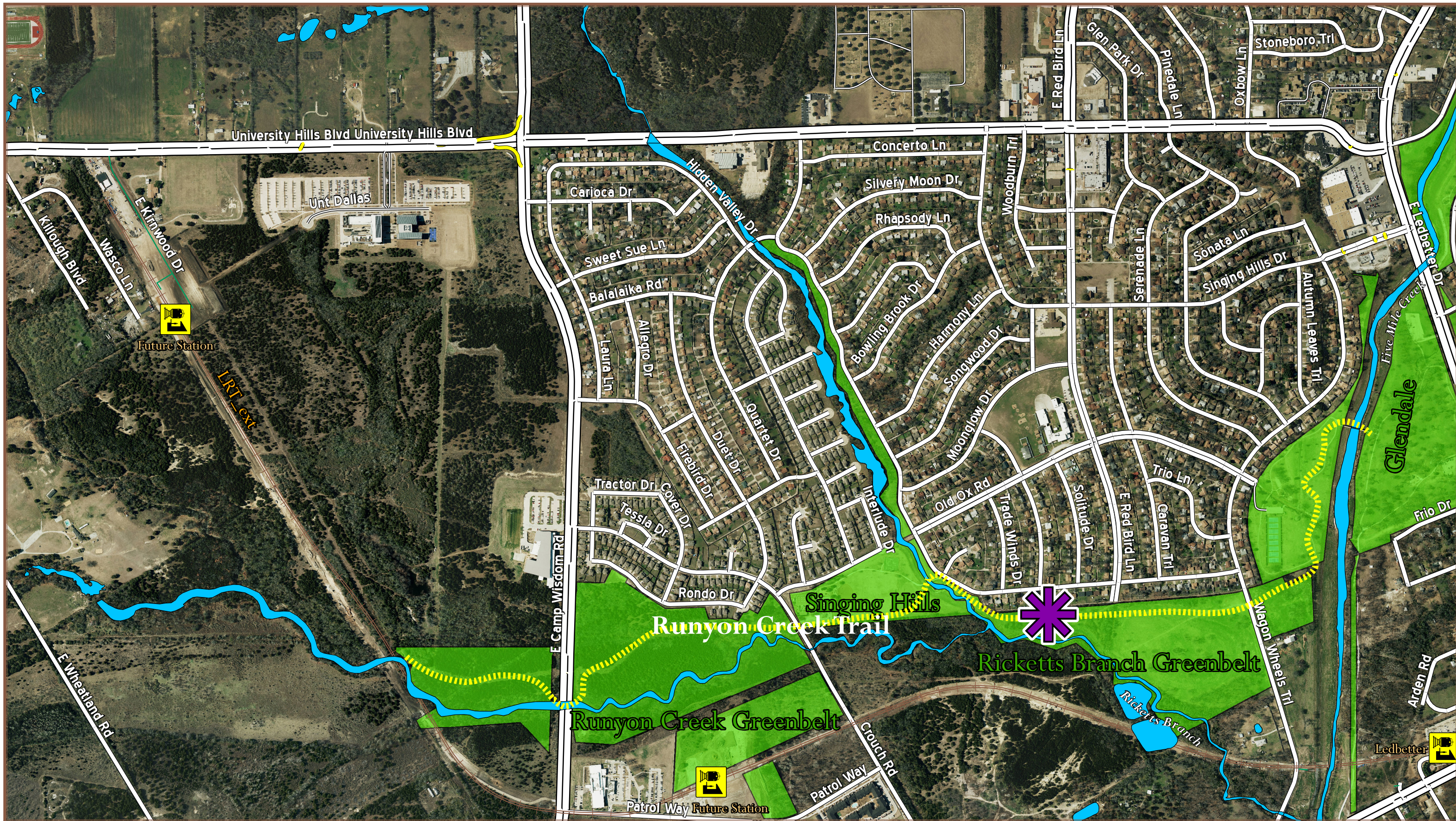

April 7, 2016

# Runyon Creek Trail (Glendale Park and Camp Wisdom Road)

MapSCO  
65 U,X,Y  
75 B

District  
3,8

**MEMORANDUM**



**DATE:** April 1, 2016

**TO:** Max W. Wells, President, and  
Members of the Dallas Park and Recreation Board

**SUBJECT:** April 7, 2016 Park and Recreation Board Briefing

---

On Thursday, April 7, 2016, the following briefing will be presented to the Dallas Park and Recreation Board:

- Proposed Management Agreement with Fair Park Texas Foundation:  
Willis Winters, Director, Park and Recreation Department

The briefing will be provided to you on Monday evening or Tuesday morning.

Should you have any questions, please contact me at 214-670-4071.

*Willis Winters*

Willis C. Winters, FAIA, FAAPRA, Director  
Park and Recreation Department